

**ROLLON®**  
Linear Evolution



**Pacific International  
Bearing, Inc.**  
800.228.8895 • [www.pibsales.com](http://www.pibsales.com)

*Linear Line*



General catalogue  
English

[www.rollon.com](http://www.rollon.com)

# When you move. We move.

Rollon S.p.A. was set up in 1975 as a manufacturer of linear motion components. Today Rollon group is a leading name in the design, production and sale of linear rails, telescopic rails and actuators, with headquarters based in Italy and offices and distributors located throughout the world. Rollon products are used in many industries with creative and efficient solutions in a wide range of applications used on a daily basis.

## Solutions for linear motion



### Linear Rails

- Rails with roller bearings
- Rails with caged ball bearings
- Rails with recirculating ball bearing



### Telescopic Rails

- Rails with partial/total extension
- Heavy duty rails
- Rails for and automated/manual applications



### Actuators

- Belt driven actuators
- Ball screw driven actuators
- Rack and pinion actuators

## Core Competencies

- > Full range of linear rails, telescopic rails and actuators
- > Worldwide presence with branches and distributors
- > Fast delivery all over the world
- > Large technical know-how for applications



### > Standard solutions

Wide range of products and sizes  
Linear rails with roller and caged ball bearings  
Heavy duty telescopic rails  
Belt or ball screw driven linear actuators  
Multi-axis systems



### > Collaboration

International know-how in several industries  
Project consultancy  
Maximizing performance and cost optimization



### > Customization

Special products  
Research and development of new solutions  
Technologies dedicated to different sectors  
Optimal surface treatment



## Applications

### Aerospace



### Railway

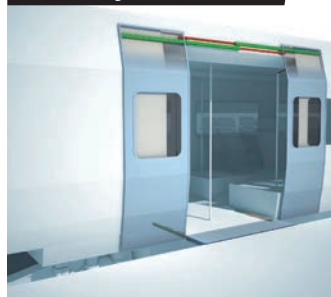

### Logistics



### Industrial Machines



### Medical



### Specialty Vehicles



### Robotics

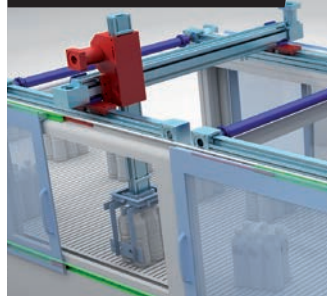

### Packaging

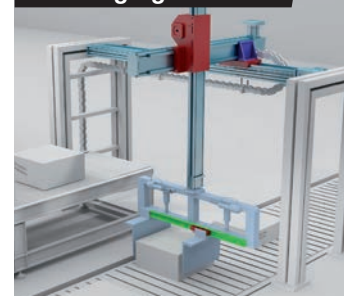

## > Compact Rail



### Technical features overview

#### 1 Product explanation

Compact Rail is the product family of roller slider systems CR-2

#### 2 Technical data

Performance characteristics and notes CR-5

Configurations and behavior of the slider  
under yawing moment  $M_z$  CR-6

Load capacities CR-8

#### 3 Product dimensions

Rail T, U, K CR-12

Rail TR (ground custom design) CR-14

Rail length CR-15

N-version slider, normal CR-16

N-version slider, long CR-18

C-version slider CR-20

T-rail with N- / C-slider CR-24

TR-rail with N- / C-slider CR-25

U-rail with N- / C-slider CR-26

K-rail with N- / C-slider CR-27

Offset of fixing holes CR-28

#### 4 Accessories

Rollers CR-29

Wipers for C-slider, Alignment fixture AT (for T- and U-rail),  
Alignment fixture AK (for K-rail) CR-30

Fixing screws CR-31

Manual clamp elements CR-32

#### 5 Technical instructions

Linear accuracy CR-33

Rigidity CR-35

Supported sides CR-39

T+U-system tolerance compensation CR-40

K+U-system tolerance compensation CR-42

Preload CR-45

Drive force CR-48

Static load CR-50

Calculation formulas CR-51

Service life calculation CR-54

Lubrication, N-slider lubrication CR-56

C-slider lubrication, Corrosion protection,  
Speed and acceleration, Operating temperatures CR-57

#### 6 Installation instructions

Fixing holes CR-58

Adjusting the sliders, Use of radial ball bearing rollers CR-59

Installing the single rail CR-60

Parallel installation of two rails CR-63

Installation of the T+U- or the K+U-system	CR-65
Joined Rails	CR-66
Installation of joined rails	CR-68

## Ordering key

Ordering key with explanations	CR-69
--------------------------------	-------

## > X Rail

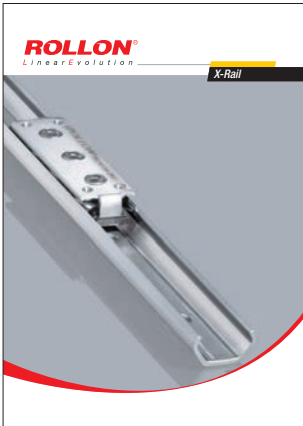

### 1 Product explanation

X-Rail: Corrosion resistant or zinc-plated steel linear bearings	XR-2
--	------

### 2 Technical data

Performance characteristics and notes	XR-4
Load capacities	XR-5

### 3 Product dimensions

Fixed rails	XR-6
Compensating rails	XR-8
Mounted sliders and rails	XR-10

### 4 Accessories

Roller Pins	XR-11
Fixing screws	XR-12

### 5 Technical instructions

Lubrication, T+U-System	XR-13
Setting preload, Use of radial ball bearing rollers	XR-15

## Ordering key

Ordering key with explanations	XR-16
Accessories	XR-17

## > **Easyslide**

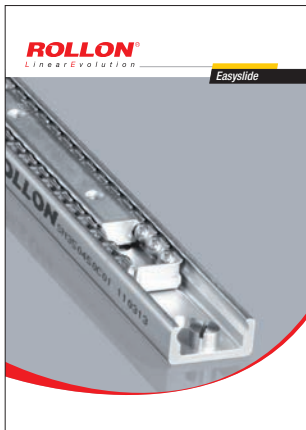

### **1 Product explanation**

Easyslide is a linear ball rail system (with caged ball bearings for the SN series or with recirculating ball bearings for the SNK series) with single slider or multiple sliders.

ES-2

### **2 Technical data**

Performance characteristics and notes

ES-4

### **3 Dimensions and load capacity**

SN

ES-5

SN

ES-9

SNK

ES-10

SNK

ES-11

### **4 Technical instructions**

Static load

ES-12

Service life

ES-14

Clearance and preload, Coefficient of friction,

Linear accuracy, Speed, Temperature

ES-15

Anticorrosive protection, Lubrication SN, Lubrication SNK

ES-16

Fixing screws, Installation instructions

ES-17

SNK Joined Rails

ES-18

Instructions for use

ES-19

### **5 Standard configurations**

SN Standard configurations

ES-20

### **Ordering key**

Ordering key with explanations

ES-22

## > Mono Rail +



### 1 Product explanation

Profile rails for the highest degree of precision

MR-3

### 2 Technical data

Performance characteristics and notes

MR-6

Load capacities

MR-7

### 3 Product dimensions

Series MRSO / MRSO...L –

carriage with flange

MR-8

Series MRSO...W / MRSO...LW –

carriage without flange

MR-10

Series MRTO / MRTO...S –

carriage with flange

MR-12

Series MRTO...W / MRTO...SW / MRTO...LW –

carriage without flange

MR-14

Series MRZO...W / MRZO...LW –

carriage without flange

MR-16

Series MRRO...F –

rail mounted from below

MR-18

### Ordering key

MR-19

## > Curviline



### 1 Product explanation

Curviline are curvilinear rails with constant and variable radii

CL-3

### 2 Technical data

Performance characteristics and notes

CL-5

### 3 Product dimensions

Rails with constant/variable radii with tempered raceways

CL-6

Slider, Mounted sliders and rails, Load capacities

CL-7

Rails with constant/variable radii in carbon steel

CL-8

Slider, Mounted sliders and rails, Load capacities

CL-9

Rails with constant/variable radii in stainless steel

CL-10

Slider in stainless steel, Rail-slider package in stainless steel, Load capacities

CL-11

### 4 Technical instructions

Anticorrosive protection, Lubrication

CL-12

Setting the preload

CL-13

### Ordering key

Ordering key with explanations

CL-14

Guides suitable for all applications

# Technical features overview



Reference		Section	Shape of rail	Hardened raceways	Self-alignment	Slider		Anticorrosion		
Family	Product					Balls	Rollers			
Compact Rail		TLC KLC ULC			√	+++			****	
	X-Rail		TEX TES UEX UES				+++			
		Easyslide		SN			√	++		
	SNK				√	+			****	
Mono Rail+		MR			√	-				
		MMR			√	-			****	
Curviline		CKR			√	+			****	
		CVR								
		CKRH								
		CVRH								
		CKRX								
		CVRX								

The information shown must be verified for the specific application.

For a complete view of technical data, please consult our catalogs on [www.rollon.com](http://www.rollon.com)

\* The maximum value is defined by the application.

\*\* A longer stroke is available for jointed versions.

\*\*\* C 50

\*\*\*\* For more information, please contact Rollon.

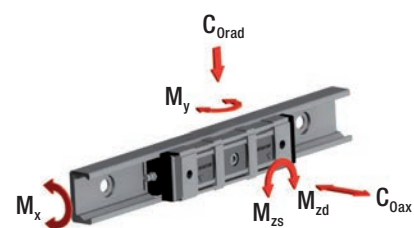

Size	Max. load capacity per slider [N]		Max. dynamic load capacity [N] C 100	Max. moment capacity [Nm]			Max. rail length [mm]	Max. Velocity* [m/s]	Max. acceleration [m/s <sup>2</sup> ]	Operating temperature
	C <sub>0</sub> rad	C <sub>0</sub> ax		M <sub>x</sub>	M <sub>y</sub>	M <sub>z</sub>				
18-28-35 -43-63	15000	10000	36600	350	689	1830	4080**	9	20	-30°C/+120°C
20-30-45	1740	935	****				3120	1.5	2	-30°C/+100°C TEX-UEX -30°C/+120°C TES-UES
22-28-35 -43-63	122000	85400	122000	1120.7	8682	12403	1970	0.8		-30°C/+130°C
43	10858	7600	10858	105	182	261	2000**	1.5		-20°C/+70°C
15-20-25- 30-35-45	169100		89500***	4430	3460	3460	4000**	3.5	20	-10°C/+60°C
7-9-12-15	8385		5065	171.7	45.7	45.7	1000**	3	250	-40°C/+80°C
16.5-23	2475	1459	****				3240	1.5	2	-30°C/+80°C

C  
RX  
RE  
SM  
R  
+C  
L



**ROLLON**<sup>®</sup>

Linear Evolution

**Compact Rail**

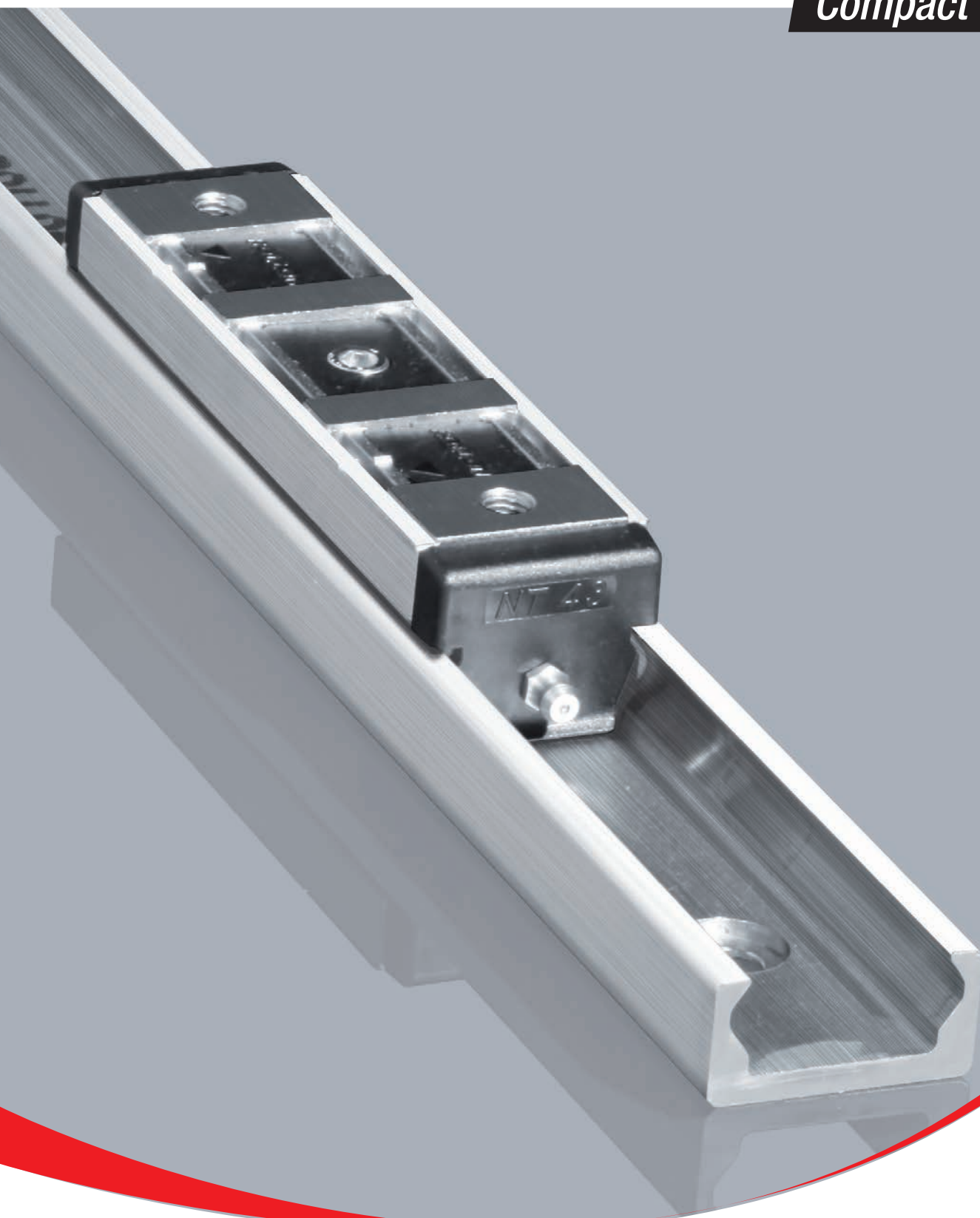

## Product explanation



### > Compact Rail is the product family of roller slider systems

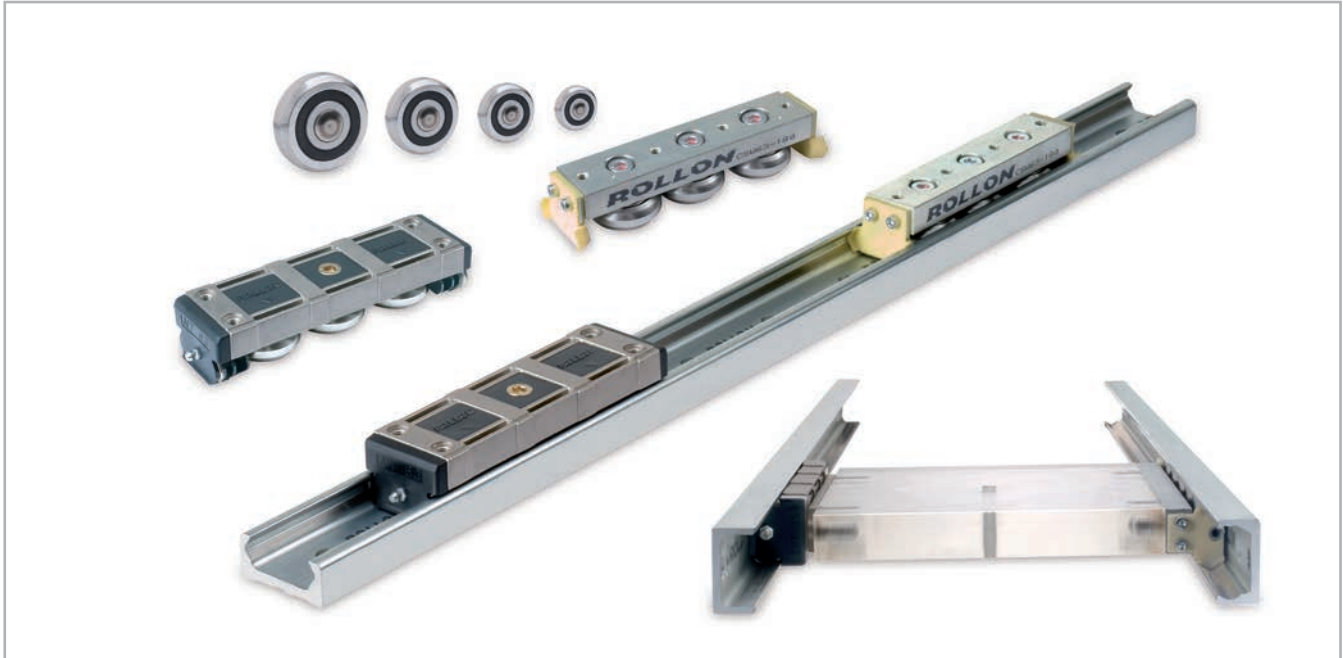

Fig. 1

Compact Rail is the product family of guide rails consisting of roller sliders with radial bearings which slide on the internal, induction hardened and ground raceways of a C-profile made from cold-drawn roller bearing carbon steel.

Compact Rail consists of three product series: the fixed bearing rail, the compensating bearing rail and the floating bearing rail. All products are available in zinc plating, with nickel plating also available as an option. There are five different sizes of guide rails and many different versions and lengths of the slide bearings.

#### Preferred areas of application:

- Cutting machines
- Medical technology
- Packaging machines
- Photographic lighting equipment
- Construction and machine technology (doors, protective covers)
- Robots and manipulators
- Automation
- Handling

#### The most important characteristics:

- Compact size
- Corrosion resistant surface
- Not sensitive to dirt due to internal tracks
- Hardened and ground raceways
- Custom design TR-rail, also ground on the back of the rail and one side surface
- Self-aligning in two planes
- Quieter than recirculating ball systems
- High operating speeds
- Wide temperature range
- Easy adjustment of slider in the guide rail
- Zinc plated surface, on request chemically nickel plated

**Fixed bearing rails (T-rails)**

Fixed bearing rails are used as the main load bearing in radial and axial forces.

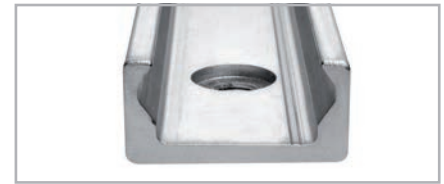

Fig. 2

**Fixed bearing rails (TR-rails)**

The TR rail is available as a custom design. The TR rail is ground on the back of the rail and one side surface to allow for a precision mounting onto a surface.



Fig. 3

**Floating bearing rails (U-rails)**

The floating bearing rails are used for load bearing of radial forces and, in combination with the fixed bearing T-rail or compensation K-rail, as a support bearing for occurring moment loads.



Fig. 4

**Compensation bearing rails (K-rails)**

The compensation bearing rails are used for the load bearing of radial and axial forces. Tolerance compensation in two planes can be implemented in combination with the U-rail.

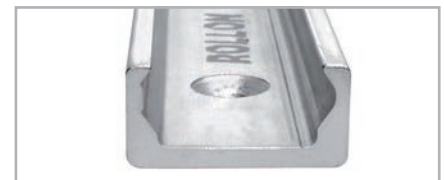

Fig. 5

**System (T+U-system)**

The combination of fixed bearing rail and floating bearing rail allows for deviations in parallelism.

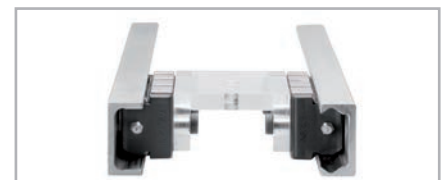

Fig. 6

**System (K+U-system)**

The combination of compensation rail and floating bearing rail allows for deviations in parallelism and height offset.



Fig. 7

### N-slider

Constructed from a, chemically nickel plated aluminum die cast body that is available for sizes 18, 28, 43 and 63. Spring preloaded wipers and a self-lubrication kit are integrated in the end caps (except for size 18, see pg. 58). Configurable with three rollers as standard, in sizes 28 and 43. A longer carriage with up to five rollers is also available.



Fig. 8

### CS-slider

Constructed with zinc-plated steel body and sturdy wipers (optional) made of polyamide. Available for all sizes. Depending on the load requirement, slider is configurable with up to six rollers.



Fig. 9

### CD-slider

Constructed with asymmetrical zinc-plated steel body and sturdy wipers (optional) made of polyamide. With this design it is possible to mount your moving element to the bottom or top of the slider body. The Slider is available for sizes 28, 35 and 43. Available with three or five rollers, depending on load case and load direction set with the corresponding configuration.



Fig. 10

### Rollers

Also available individually in all sizes. Available as eccentric or concentric rollers. Optionally available with splash-proof plastic seal (2RS) or with steel cover disc (Z2).



Fig. 11

### Wipers

Wipers are available for slider types CS and CD and are made of sturdy polyamide. They keep the raceways free of contamination and thus ensure a longer service life.

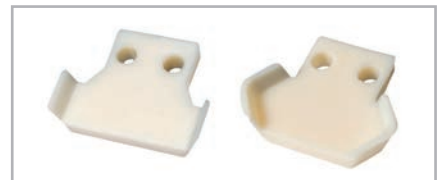

Fig. 12

### Alignment fixture

The alignment fixture AT / AK is used during installation of joined rails for precise alignment of the rail transition from one to another.



Fig. 13

## Technical data

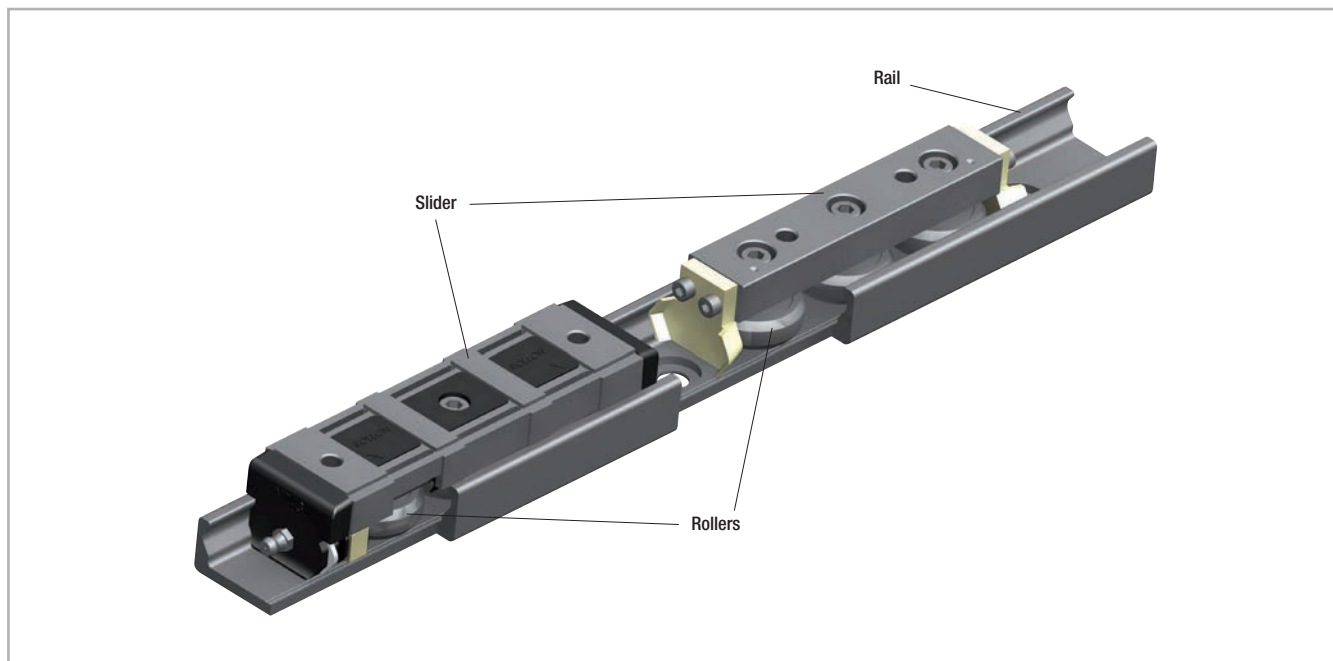

Fig. 14

### Performance characteristics:

- Available sizes for T-rail, TR-rail, U-rail: 18, 28, 35, 43, 63
- Available sizes for K-rail: 43, 63
- Max. operating speed: 9 m/s (354 in/s)  
(depending on application)
- Max. acceleration: 20 m/s<sup>2</sup> (787 in/s<sup>2</sup>)  
(depending on application)
- Max. radial load capacity: 15,000 N (per slider)
- Temperature range: -30 °C to +120 °C (-22 °F to +248 °F)  
briefly up to max. +170 °C (+338 °F)
- Available rail lengths from 160 mm to 3,600 mm (6.3 in to 142 in)  
in 80-mm increments (3.15 in),  
longer single rails up to max. 4,080 mm (160.6 in) on request
- Roller pins lubricated for life
- Roller seal/shield: 2RS (splash-proof), 2Z (steel cover disk)
- Roller material: steel 100Cr6
- Rail raceways are induction hardened and ground
- Rails and slider bodies are standard zinc-plated according to ISO 2081
- Rail material of T- and U-rails in sizes 18:  
cold-drawn roller bearing carbon steel C43 F
- Rail material of K-rails, as well as T- and U-rails in size 28 to 63:  
CF53

### Notes:

- The sliders are equipped with rollers that are in alternating contact with both sides of the raceway. Markings on the body around the roller pins indicate correct arrangement of the rollers to the external load
- With a simple adjustment of the eccentric rollers, the desired clearance or preload on the rail and slider can be set.
- Rails in joined design are available for longer transverse distances (see pg. CR-64)
- The K rails are not suitable for vertical installation
- Screws of property class 10.9 must be used
- Differences in screw sizes must be observed
- When mounting the rails, it is crucial to ensure that the mounting holes in the structure are properly chamfered. (see pg. CR-58, tab. 41)
- The general illustrations show N-sliders as an example

## > Configurations and behavior of the slider under yawing moment $M_z$

### Individual slider under $M_z$ moment load

When an overhanging load in an application with a single slider per rail causes an  $M_z$  moment in one direction, a 4 to 6 roller Compact Rail slider is available. These sliders are available in both configuration A and B in regards to the roller arrangement to counter the acting  $M_z$  moment load. The moment capacity of these sliders in the  $M_z$ -direction varies significantly through spacing  $L_1$  and  $L_2$  in accordance with the direction of rotation of  $M_z$ . Especially in the use of two parallel rails, for example with a T+U-system,

it is extremely important to pay attention to the correct combination of the slider configuration A and B, in order to use the maximum load capacities of the slider.

The diagrams below illustrate this concept of the A and B configuration for sliders with 4 and 6 rollers. The maximum allowable  $M_z$ -moment is identical in both directions for all 3 and 5 roller sliders.

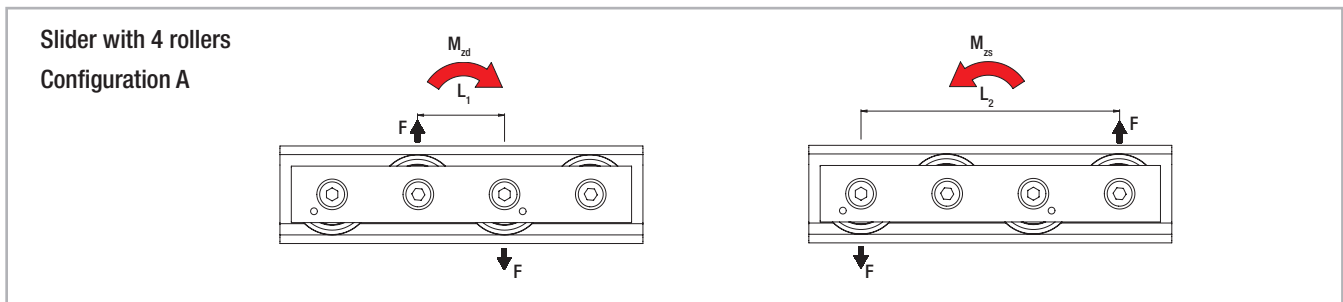

Fig. 15

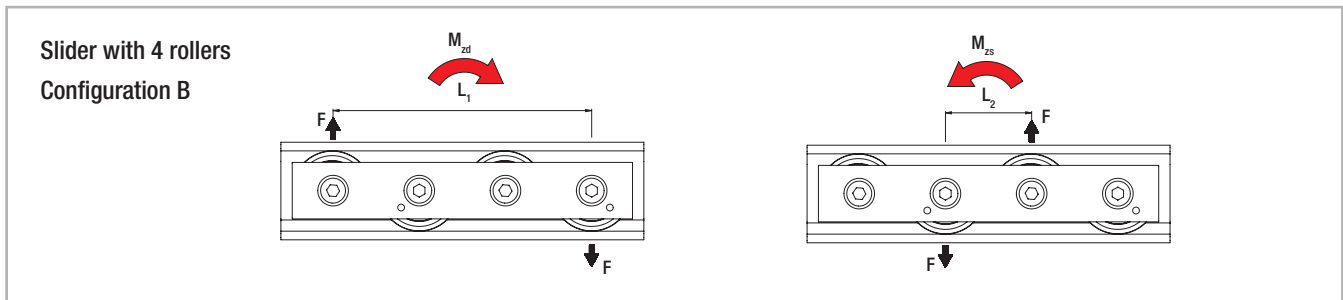

Fig. 16

### Two sliders under $M_z$ moment load

When an overhanging load acts on an application with two sliders per rail and causes an  $M_z$ -moment in one direction, there are differing support reactions with the two sliders. For this reason, an optimal arrangement of different slider configurations to reach the maximum load capacities must be achieved for this type of application. In practice this means, when using NTE-, NUE- or CS-sliders with 3 or 5 rollers, both sliders are installed rotated by  $180^\circ$  so that the slider is always loaded on the side with the most

rollers (with NKE-sliders this is not possible due to the different raceway geometry). For an even number of rollers this has no effect. The CD-slider with installation option from above or below cannot be installed due to the position of the rollers in reference to the installation side therefore they are available in the configurations A and B (see fig. 18).

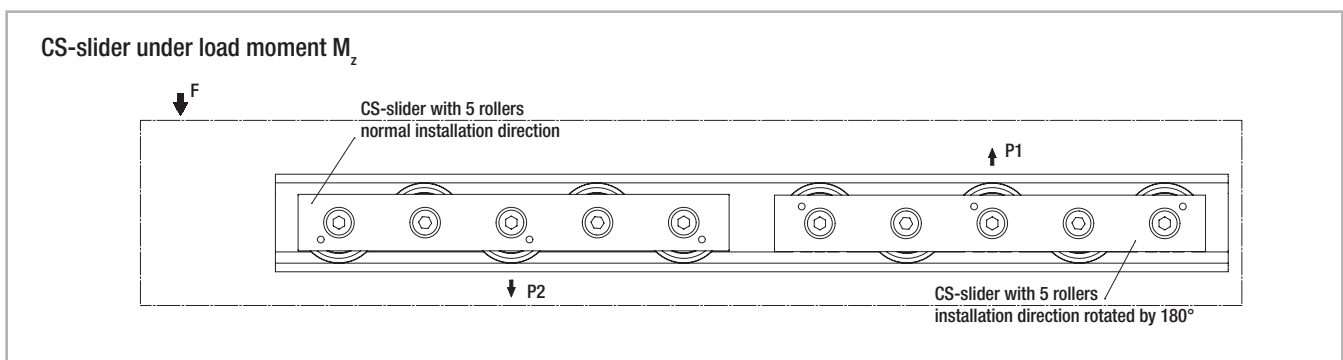

Fig. 17



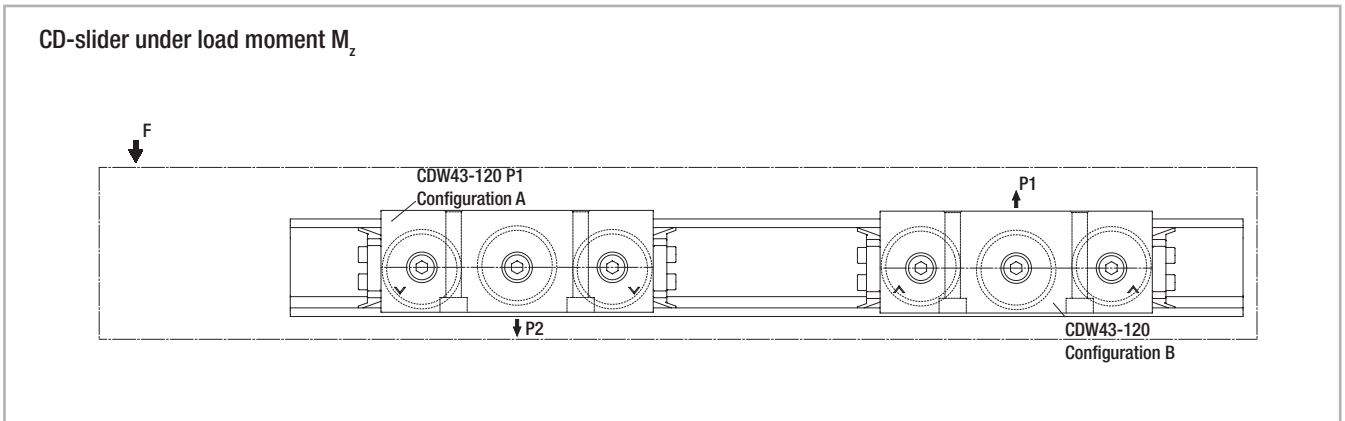

Fig. 18

**Slider configurations for various load cases**

**Arrangement DS**

This is the recommended arrangement for use of two sliders under  $M_z$ -moment when using one rail. Also see previous page: Two sliders under  $M_z$  moment load.

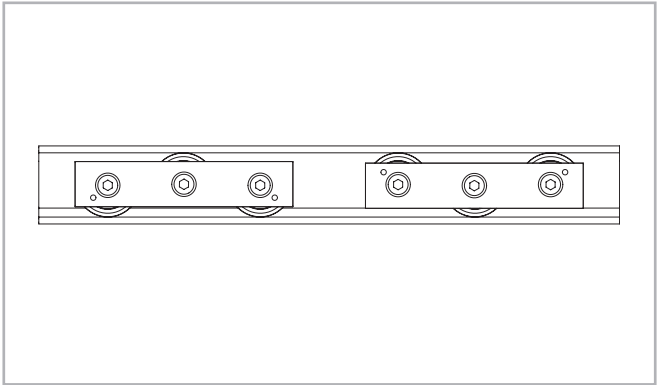

Fig. 19

**Arrangement DD**

For using a pair of guide rails with two sliders each under  $M_z$  moment load, the second system should be designed in arrangement DD. This results in the following combination: One guide rail with two sliders in arrangement DS and the other guide rail with 2 sliders in arrangement DD. This allows even load and moment distribution between the two parallel rails.

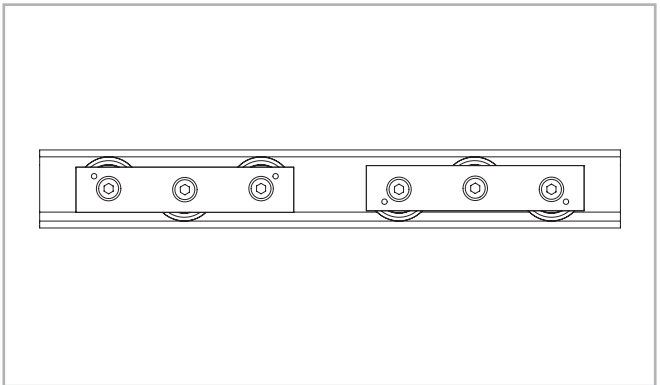

Fig. 20

**Arrangement DA**

Standard arrangement if no other information is given. This arrangement is recommended if the load point is located within the two outside points of the sliders.

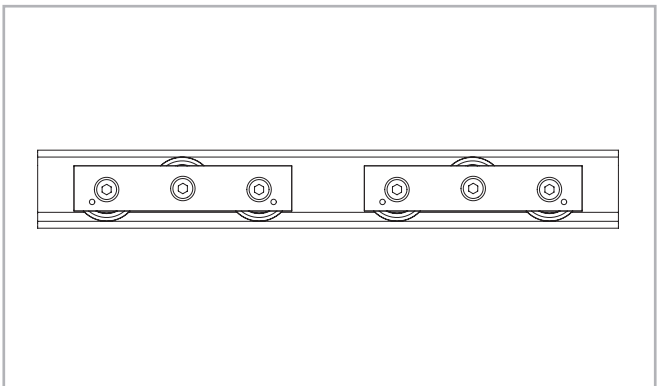

Fig. 21

C  
R

> Load capacities

Slider

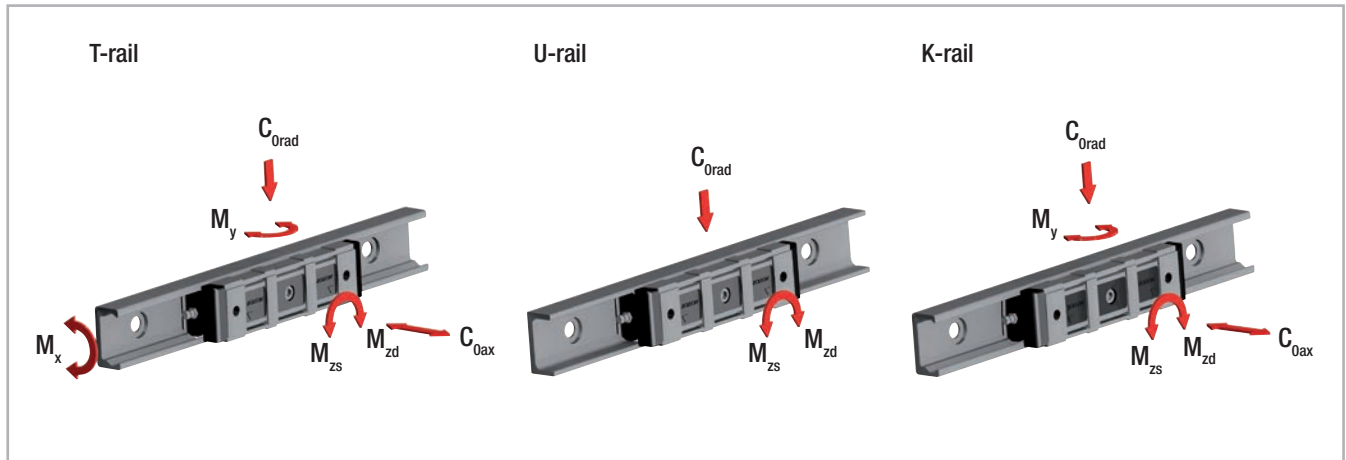

Fig. 22

The load capacities in the following tables each apply for one slider.

When using the slider in U-rails (floating bearing rails) the values are  $C_{0ax} = 0$ ,  $M_x = 0$  and  $M_y = 0$ . When using the sliders in K-rails (compensation rails) the value is:  $M_x = 0$ .

Type	Number of rollers	Load capacities and moments							Weight [kg]
		C [N]	$C_{Orad}$ [N]	$C_{0ax}$ [N]	$M_x$ [Nm]	$M_y$ [Nm]	$M_z$ [Nm]		
							$M_{zd}$	$M_{zs}$	
NT18	3	1530	820	260	1.5	4.7	8.2	8.2	0.03
NU18	3	1530	820	0	0	0	8.2	8.2	0.03
CS18-060-...	3	1530	820	260	1.5	4.7	8.2	8.2	0.04
CS18-080-...-A	4	1530	820	300	2.8	7	8.2	24.7	0.05
CS18-080-...-B	4	1530	820	300	2.8	7	24.7	8.2	0.05
CS18-100-...	5	1830	975	360	2.8	9.4	24.7	24.7	0.06
CS18-120-...-A	6	1830	975	440	3.3	11.8	24.7	41.1	0.07
CS18-120-...-B	6	1830	975	440	3.3	11.8	41.1	24.7	0.07

Tab. 1

Type	Number of rollers	Load capacities and moments							Weight [kg]
		C [N]	C <sub>Orad</sub> [N]	C <sub>Oax</sub> [N]	M <sub>x</sub> [Nm]	M <sub>y</sub> [Nm]	M <sub>z</sub> [Nm]		
							M <sub>zd</sub>	M <sub>zs</sub>	
NTE28	3	4260	2170	640	6.2	16	27.2	27.2	0.115
NUE28	3	4260	2170	0	0	0	27.2	27.2	0.115
NTE28L-3-A	3	4260	2170	640	6.2	29	54.4	54.4	0.141
NTE28L-4-A	4	4260	2170	750	11.5	29	54.4	108.5	0.164
NTE28L-4-B	4	4260	2170	750	11.5	29	108.5	54.4	0.164
NTE28L-4-C	4	4260	2170	750	11.5	29	81.7	81.7	0.164
NTE28L-5-A	5	5065	2580	900	11.5	29	81.7	81.7	0.185
NTE28L-5-B	5	6816	3472	640	6.2	29	54.4	54.4	0.185
NUE28L-3-A	3	4260	2170	0	0	0	54.4	54.4	0.141
NUE28L-4-A	4	4260	2170	0	0	0	54.4	108.5	0.164
NUE28L-4-B	4	4260	2170	0	0	0	108.5	54.4	0.164
NUE28L-4-C	4	4260	2170	0	0	0	81.7	81.7	0.164
NUE28L-5-A	5	5065	2580	0	0	0	81.7	81.7	0.185
NUE28L-5-B	5	6816	3472	0	0	0	54.4	54.4	0.185
CS28-080-...	3	4260	2170	640	6.2	16	27.2	27.2	0.155
CS28-100-...-A	4	4260	2170	750	11.5	21.7	27.2	81.7	0.195
CS28-100-...-B	4	4260	2170	750	11.5	21.7	81.7	27.2	0.195
CS28-125-...	5	5065	2580	900	11.5	29	81.7	81.7	0.24
CS28-150-...-A	6	5065	2580	1070	13.7	36.2	81.7	136.1	0.29
CS28-150-...-B	6	5065	2580	1070	13.7	36.2	136.1	81.7	0.29
CD28-080-...	3	4260	2170	640	6.2	16	27.2	27.2	0.215
CD28-125-...	5	5065	2580	900	11.5	29	81.7	81.7	0.3
CS35-100-...	3	8040	3510	1060	12.9	33.7	61.5	61.5	0.27
CS35-120-...-A	4	8040	3510	1220	23.9	43.3	52.7	158.1	0.33
CS35-120-...-B	4	8040	3510	1220	23.9	43.3	158.1	52.7	0.33
CS35-150-...	5	9565	4180	1460	23.9	57.7	158.1	158.1	0.41
CS35-180-...-A	6	9565	4180	1780	28.5	72.2	158.1	263.4	0.49
CS35-180-...-B	6	9565	4180	1780	28.5	72.2	263.4	158.1	0.49
CD35-100-...	3	8040	3510	1060	12.9	33.7	61.5	61.5	0.39
CD35-150-...	5	9565	4180	1460	23.9	57.7	158.1	158.1	0.58

Tab. 2

Type	Number of rollers	Load capacities and moments							Weight [kg]
		C [N]	C <sub>Grad</sub> [N]	C <sub>0ax</sub> [N]	M <sub>x</sub> [Nm]	M <sub>y</sub> [Nm]	M <sub>z</sub> [Nm]		
							M <sub>zd</sub>	M <sub>zs</sub>	
NTE43	3	12280	5500	1570	23.6	60	104.5	104.5	0.385
NUE43	3	12280	5500	0	0	0	104.5	104.5	0.385
NKE43	3	12280	5100	1320	0	50.4	96.9	96.9	0.385
NTE43L-3-A	3	12280	5500	1570	23.6	108.6	209	209	0.45
NTE43L-4-A	4	12280	5500	1855	43.6	108.6	209	418	0.52
NTE43L-4-B	4	12280	5500	1855	43.6	108.6	418	209	0.52
NTE43L-4-C	4	12280	5500	1855	43.6	108.6	313.5	313.5	0.52
NTE43L-5-A	5	14675	6540	2215	43.6	108.6	313.5	313.5	0.59
NTE43L-5-B	5	19650	8800	1570	23.6	108.6	209	209	0.59
NUE43L-3-A	3	12280	5500	0	0	0	209	209	0.45
NUE43L-4-A	4	12280	5500	0	0	0	209	418	0.52
NUE43L-4-B	4	12280	5500	0	0	0	418	209	0.52
NUE43L-4-C	4	12280	5500	0	0	0	313.5	313.5	0.52
NUE43L-5-A	5	14675	6540	0	0	0	313.5	313.5	0.59
NUE43L-5-B	5	19650	8800	0	0	0	209	209	0.59
NKE43L-3-A	3	12280	5100	1320	0	97.7	188.7	188.7	0.45
NKE43L-4-A	4	12280	5100	1320	0	97.7	188.7	377.3	0.52
NKE43L-4-B	4	12280	5100	1320	0	97.7	377.3	188.7	0.52
NKE43L-4-C	4	12280	5100	1320	0	97.7	283	283	0.52
NKE43L-5-A	5	14675	6065	1570	0	97.7	283	283	0.59
NKE43L-5-B	5	19650	8160	1820	0	97.7	188.7	188.7	0.59
CS43-120-...	3	12280	5500	1570	23.6	60	104.5	104.5	0.53
CS43-150-...-A	4	12280	5500	1855	43.6	81.5	104.5	313.5	0.68
CS43-150-...-B	4	12280	5500	1855	43.6	81.5	313.5	104.5	0.68
CS43-190-...	5	14675	6540	2215	43.6	108.6	313.5	313.5	0.84
CS43-230-...-A	6	14675	6540	2645	52	135.8	313.5	522.5	1.01
CS43-230-...-B	6	14675	6540	2645	52	135.8	522.5	313.5	1.01

Tab. 3

Type	Number of rollers	Load capacities and moments							Weight [kg]
		C [N]	C <sub>Orad</sub> [N]	C <sub>Oax</sub> [N]	M <sub>x</sub> [Nm]	M <sub>y</sub> [Nm]	M <sub>z</sub> [Nm]		
							M <sub>zd</sub>	M <sub>zs</sub>	
CSK43-120-...	3	12280	5100	1320	0	50.4	96.9	96.9	0.53
CSK43-150-A	4	12280	5100	1320	0	54.3	96.9	290.7	0.68
CSK43-150-B	4	12280	5100	1320	0	54.3	290.7	96.9	0.68
CSK43-190-...	5	14675	6065	1570	0	108.7	290.7	290.7	0.84
CSK43-230-A	6	14675	6065	1570	0	108.7	290.7	484.5	1.01
CSK43-230-B	6	14675	6065	1570	0	108.7	484.5	290.7	1.01
CD43-120-...	3	12280	5500	1570	23.6	60	104.5	104.5	0.64
CD43-190-...	5	14675	6540	2215	43.6	108.6	313.5	313.5	0.95
CDK43-120-...	3	12280	5100	1320	0	50.4	96.9	96.9	0.64
CDK43-190-...	5	14675	6065	1570	0	108.7	290.7	290.7	0.95
NTE63	3	30750	12500	6000	125	271	367	367	1.07
NUE63	3	30750	12500	0	0	0	367	367	1.07
NKE63	3	30750	11550	5045	0	235	335	335	1.07
CS63-180-2ZR	3	30750	12500	6000	125	271	367	367	1.66
CS63-235-2ZR-A	4	30750	12500	7200	250	413	367	1100	2.17
CS63-235-2ZR-B	4	30750	12500	7200	250	413	1100	367	2.17
CS63-290-2ZR	5	36600	15000	8500	250	511	1100	1100	2.67
CS63-345-2ZR-A	6	36600	15000	10000	350	689	1100	1830	3.17
CS63-345-2ZR-B	6	36600	15000	10000	350	689	1830	1100	3.17
CSK63-180-2ZR	3	30750	11550	5045	0	235	335	335	1.66
CSK63-235-2ZR-A	4	30750	11550	5045	0	294	335	935	2.17
CSK63-235-2ZR-B	4	30750	11550	5045	0	294	935	335	2.17
CSK63-290-2ZR	5	36600	13745	6000	0	589	935	935	2.67
CSK63-345-2ZR-A	6	36600	13745	6000	0	589	935	1560	3.17
CSK63-345-2ZR-B	6	36600	13745	6000	0	589	1560	935	3.17

Tab. 4

# Product dimensions



## > Rail T, U, K

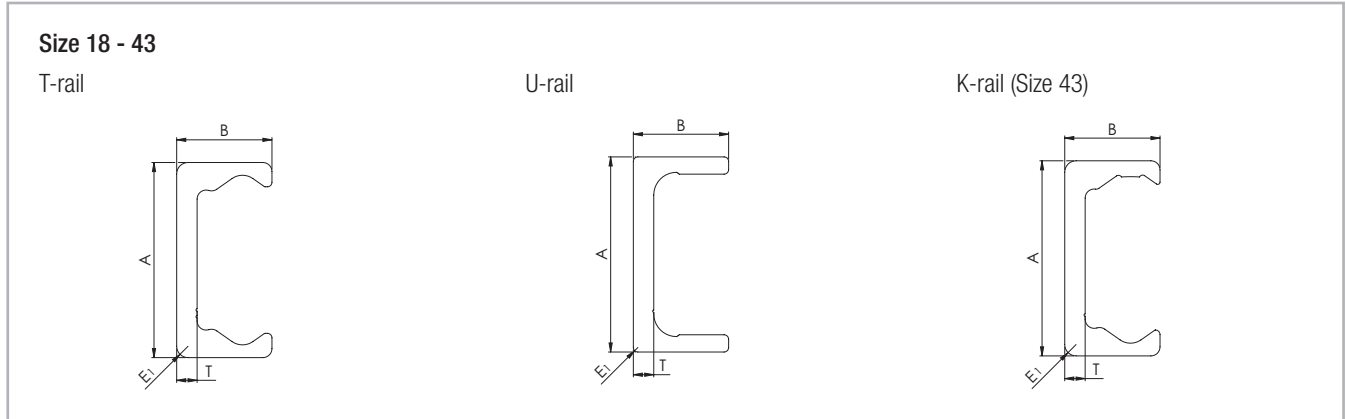

Fig. 23

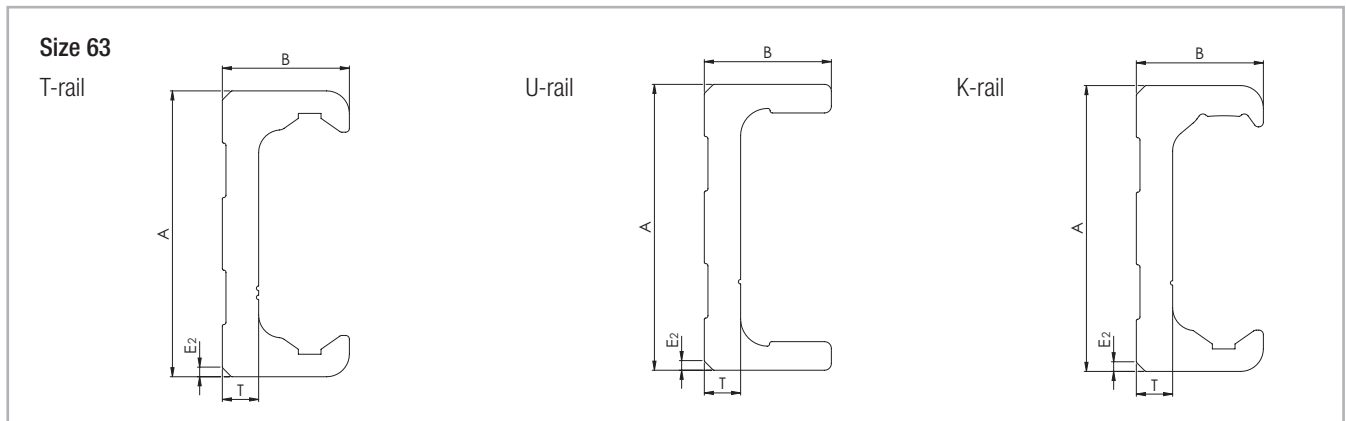

Fig. 24

## Holes

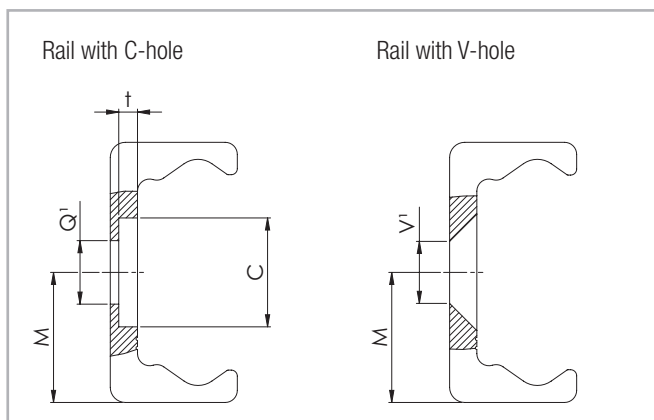

Fig. 25

Q1 Fixing holes for Torx® screws with low head (custom design) included in scope of supply

V1 Fixing holes for countersunk head screws according to DIN 7991

Type	Size	A [mm]	B [mm]	M [mm]	E <sub>1</sub> [mm]	T [mm]	C [mm]	Weight [kg/m]	E <sub>2</sub> [°]	t [mm]	Q' [mm]	V' [mm]
TLC TLV	18	18	8.25	9	1.5	2.8	9.5	0.55	-	2	M4	M4
	28	28	12.25	14	1	3	11	1.0	-	2	M5	M5
	35	35	16	17.5	2	3.5	14.5	1.65	-	2.7	M6	M6
	43	43	21	21.5	2.5	4.5	18	2.6	-	3.1	M8	M8
	63	63	28	31.5	-	8	15	6.0	2x45	5.2	M8	M10
ULC ULV	18	18	8.25	9	1	2.6	9.5	0.55	-	1.9	M4	M4
	28	28	12	14	1	3	11	1.0	-	2	M5	M5
	35	35	16	17.5	1	3.5	14.5	1.65	-	2.7	M6	M6
	43	43	21	21.5	1	4.5	18	2.6	-	3.1	M8	M8
	63	63	28	31.5	-	8	15	6.0	2x45	5.2	M8	M10
KLC KLV	43	43	21	21.5	2.5	4.5	18	2.6	-	3.1	M8	M8
	63	63	28	31.5	-	8	15	6.0	2x45	5.2	M8	M10

Tab. 5

C  
R

> Rail TR (ground custom design)

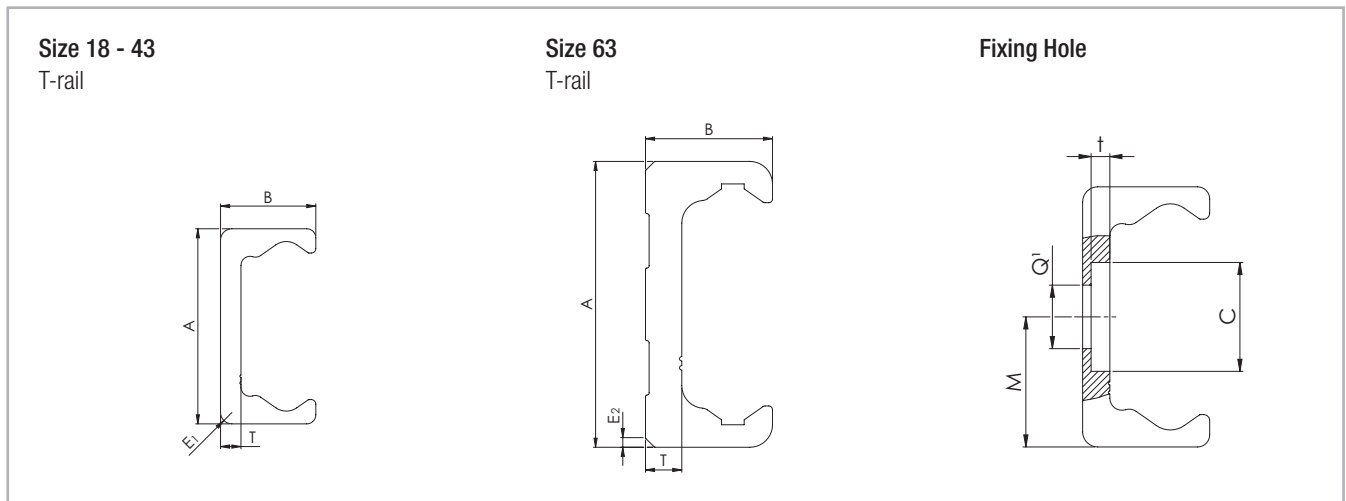

Q<sub>1</sub> Fixing holes for Torx® screws with low head (custom design) included in scope of supply

Fig. 26

Type	Size	A [mm]	B [mm]	M [mm]	E <sub>1</sub> [mm]	T [mm]	C [mm]	Weight [kg/m]	E <sub>2</sub> [°]	t [mm]	Q <sub>1</sub> [mm]
TRC	18	17.95	8	8.95	1.5	2.8	9.5	0.55	-	2	M4
	28	27.83	12.15	13.83	1	2.9	11	1.0	-	2	M5
	35	34.8	15.9	17.3	2	3.4	14.5	1.6	-	2.7	M6
	43	42.75	20.9	21.25	2.5	4.4	18	2.6	-	3.1	M8
	63	62.8	27.9	31.3	-	7.9	15	6.0	2x45	5.2	M8

Tab. 6



> Rail length

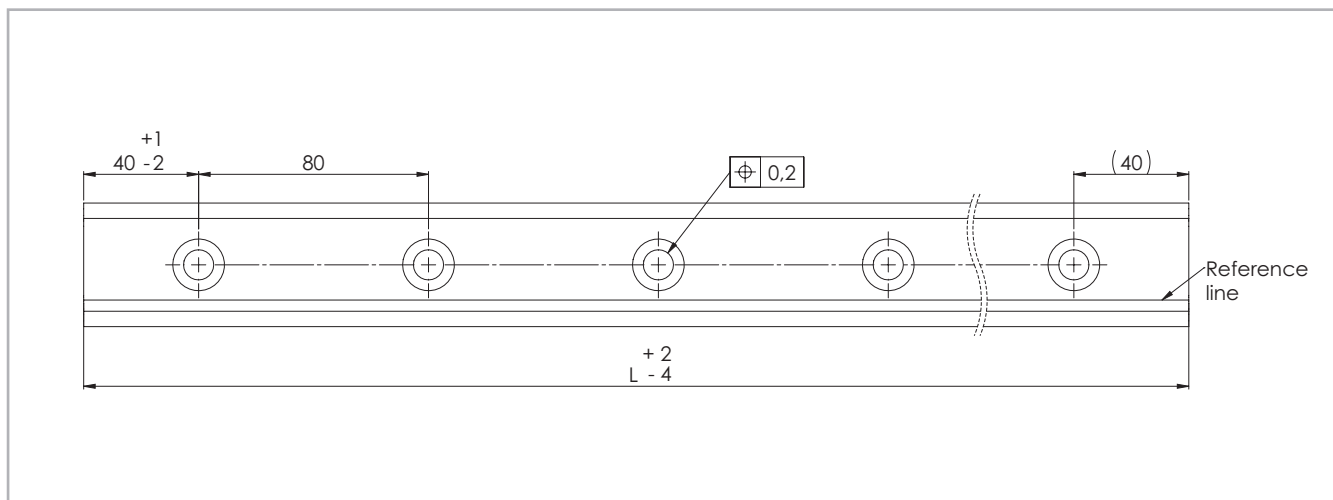

Fig. 27

Type	Size	Min length [mm]	Max length [mm]	Available standard lengths L [mm]
TLC TLV ULC ULV	18	160	2000	160 - 240 - 320 - 400 - 480 - 560 - 640 - 720 - 800 - 880 - 960 - 1040 - 1120 - 1200 - 1280 - 1360 - 1440 - 1520 - 1600 - 1680 - 1760 - 1840 - 1920 - 2000 - 2080 - 2160 - 2240 - 2320 - 2400 - 2480 - 2560 - 2640 - 2720 - 2800 - 2880 - 2960 - 3040 - 3120 - 3200 - 3280 - 3360 - 3440 - 3520 - 3600
	28	240	3200	
	35	320	3600	
	43	400	3600	
	63	560	3600	
KLC KLV	43	400	3600	
	63	560	3600	
TRC	18	160	2000	
	28	240	2000	
	35	320	2000	
	43	400	2000	
	63	560	2000	

Tab. 7

Longer single rails up to max. 4,080 mm on request  
Longer rail systems see pg. CR-66 Joined rails

> N-version slider, normal

N-series

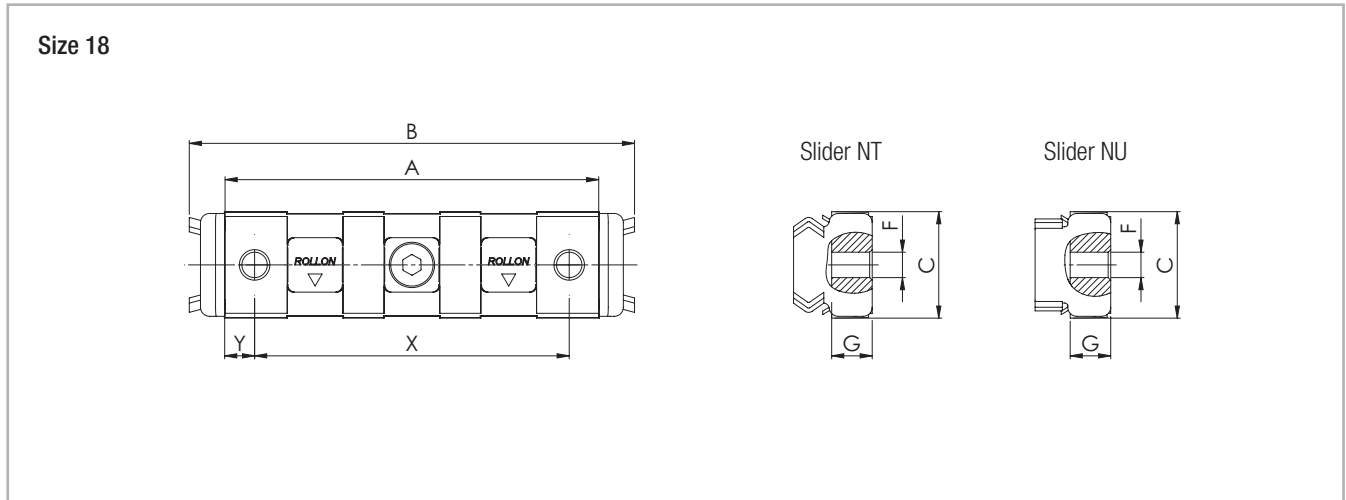

Fig. 28

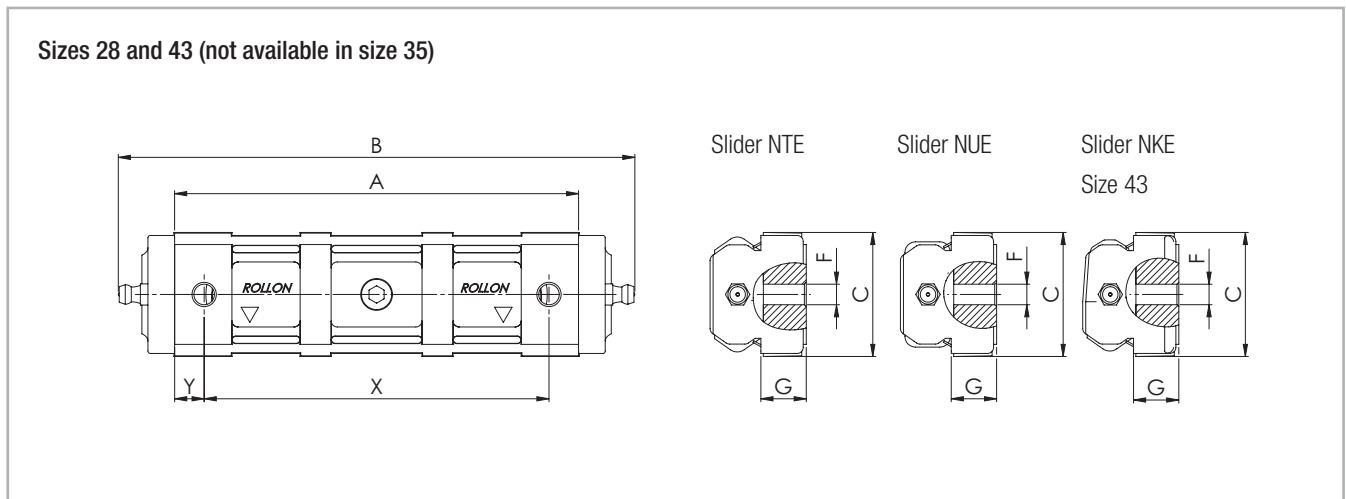

Fig. 29

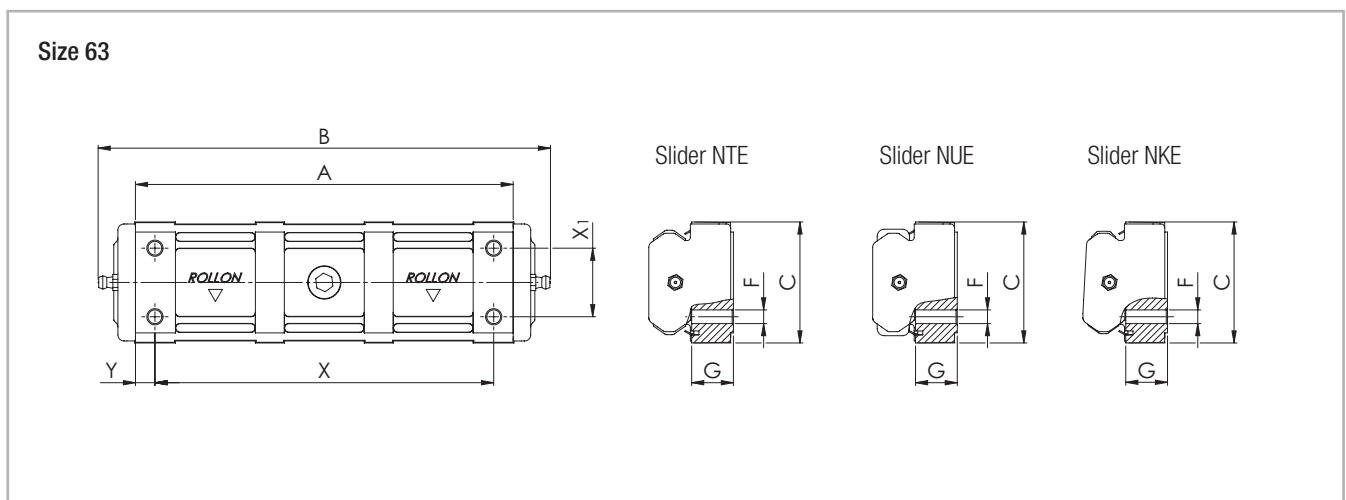

Fig. 30

Type	Size	A [mm]	B [mm]	C [mm]	G [mm]	F [mm]	X [mm]	Y [mm]	X <sub>1</sub> [mm]	No. of holes	Roller type used*	Number of Rollers
NT NU	18	62	74	17.6	6.4	M5	52	5	-	2	CPA18-CPN18	3
NTE NUE	28	88	124	26,5	9.3	M5	78	5	-	2	CPA28-CPN28	3
NTE NUE	43	134	170	40	13.7	M8	114	10	-	2	CPA43-CPN43	3
NKE	43	134	170	40	13.7	M8	114	10	-	2	CRA43-CRN43	3
NTE NUE	63	188	225	60	20.2	M8	168	10	34	4	CPA63-CPN63	3
NKE	63	188	225	60	20.2	M8	168	10	34	4	CRA63-CRN63	3

\* Information about the roller type, see pg. CR-29, tab. 18

Tab. 8

> N-version slider, long

N...L-series

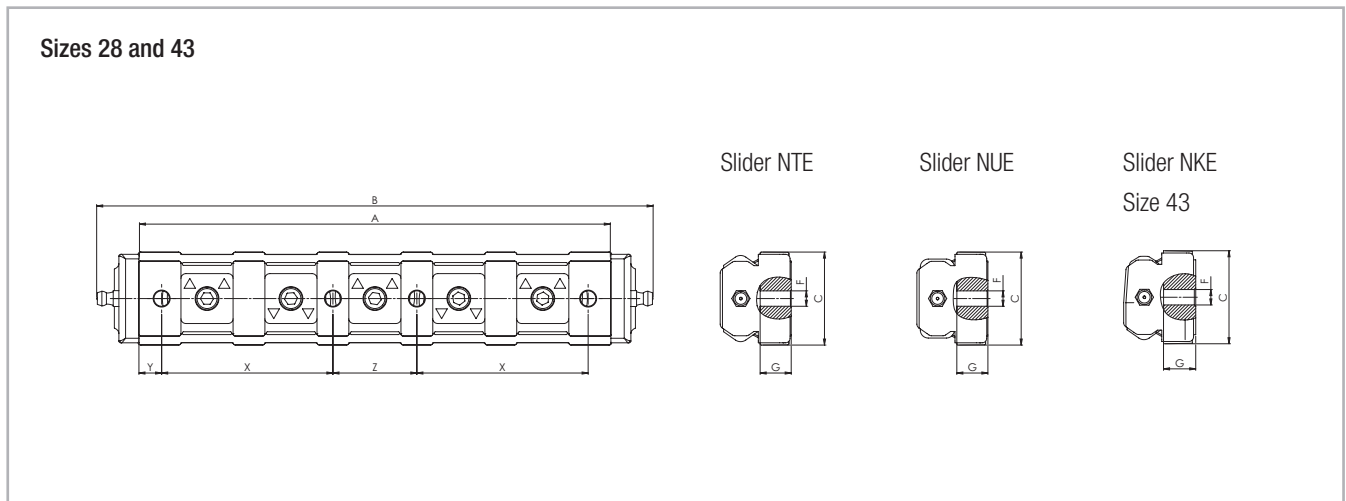

Fig. 31

Slider configurations N...L

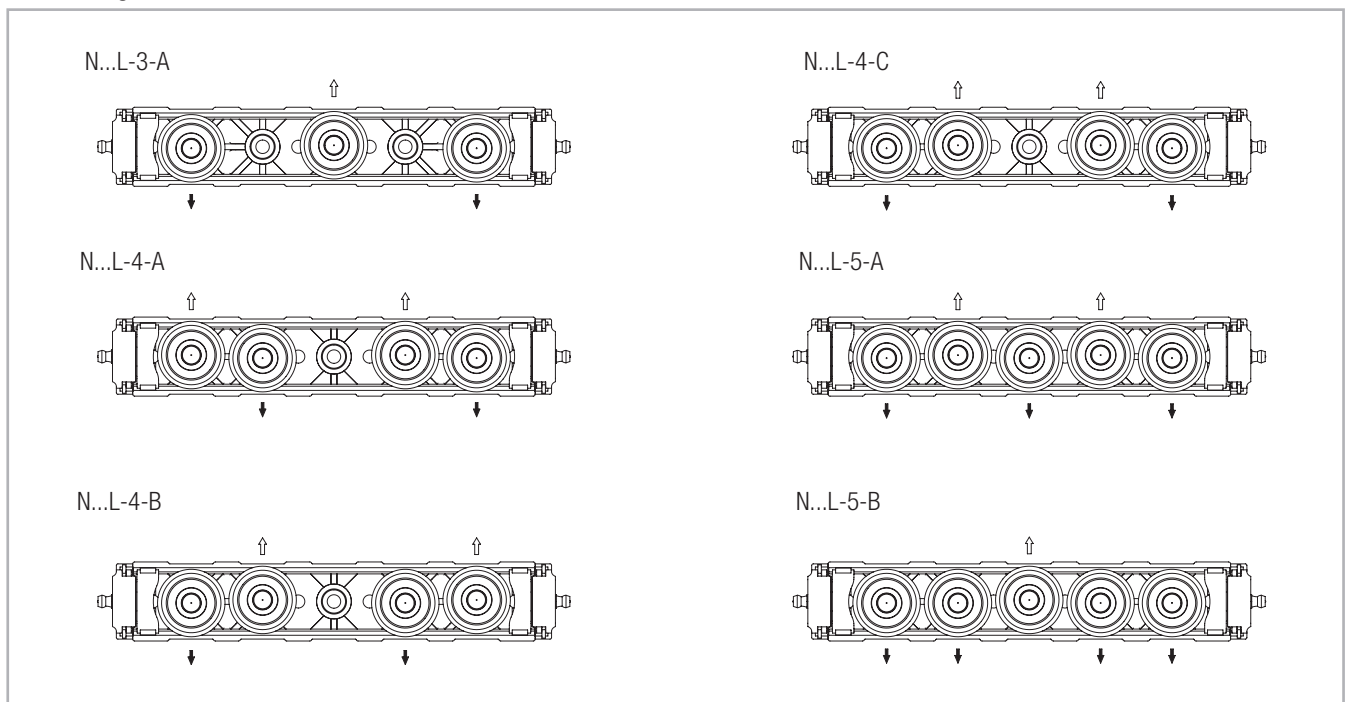

Fig. 32

Type	Size	A [mm]	B [mm]	C [mm]	G [mm]	F [mm]	X [mm]	Y [mm]	Z [mm]	No. of holes	Roller type used*	Number** of Rollers
NTE28L NUE28L	28	140	176	26.5	9	M5	52	5	26	4	CPA28	3 4 5
NTE43L NUE43L	43	208	245	41	13.7	M8	75.5	10	37	4	CPA43	3 4 5
NKE43L											CRA43	

\* Information about the roller type, see pg. CR-29, tab. 18

\*\* The number of roller varies according to the configuration, see pg. CR-18, fig. 32

Tab. 9

> C-version slider

CS-series

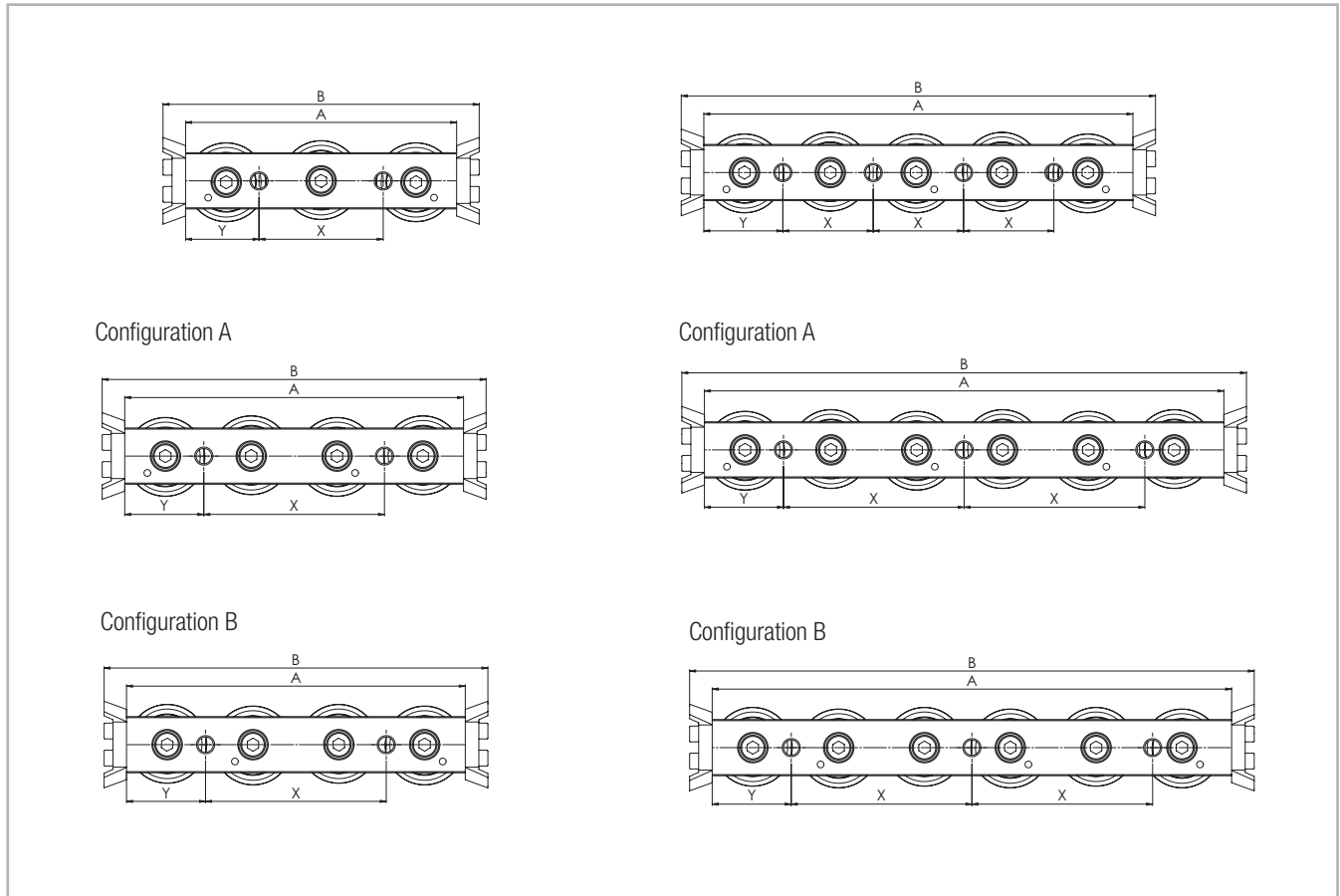

Representation of slider with wiper

Fig. 33

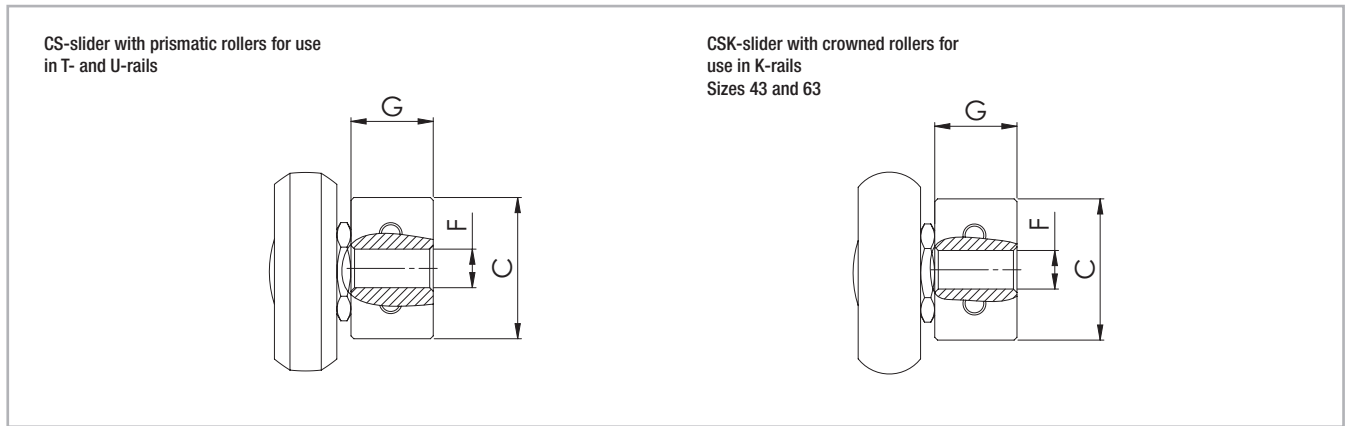

Fig. 34

Type	Size	A [mm]	B [mm]	C [mm]	G [mm]	F [mm]	X [mm]	Y [mm]	No. of holes	Roller type used*	Number of Rollers
CS	18	60	76	9.5	5.7	M5	20	20	2	CPA18-CPN18	3
		80	96	9.5	5.7	M5	40	20	2	CPA18	4
		100	116	9.5	5.7	M5	20	20	4	CPA18	5
		120	136	9.5	5.7	M5	40	20	3	CPA18	6
	28	80	100	14.9	9.7	M5	35	22.5	2	CPA28-CPN28	3
		100	120	14.9	9.7	M5	50	25	2	CPA28	4
		125	145	14.9	9.7	M5	25	25	4	CPA28	5
		150	170	14.9	9.7	M5	50	25	3	CPA28	6
	35	100	120	19.9	11.9	M6	45	27.5	2	CPA35-CPN35	3
		120	140	19.9	11.9	M6	60	30	2	CPA35	4
		150	170	19.9	11.9	M6	30	30	4	CPA35	5
		180	200	19.9	11.9	M6	60	30	3	CPA35	6
	43	120	140	24.9	14.5	M8	55	32.5	2	CPA43-CPN43	3
		150	170	24.9	14.5	M8	80	35	2	CPA43	4
		190	210	24.9	14.5	M8	40	35	4	CPA43	5
		230	250	24.9	14.5	M8	80	35	3	CPA43	6
	63	180	200	39.5	19.5	M8	54	9	4	CPA63	3
		235	255	39.5	19.5	M8	54	9.5	5	CPA63	4
		290	310	39.5	19.5	M8	54	10	6	CPA63	5
		345	365	39.5	19.5	M8	54	10.5	7	CPA63	6
CSK	43	120	140	24.9	14.5	M8	55	32.5	2	CRA43-CRN43	3
		150	170	24.9	14.5	M8	80	35	2	CRA43	4
		190	210	24.9	14.5	M8	40	35	4	CRA43	5
		230	250	24.9	14.5	M8	80	35	3	CRA43	6
	63	180	200	39.5	19.5	M8	54	9	4	CRA63	3
		235	255	39.5	19.5	M8	54	9.5	5	CRA63	4
		290	310	39.5	19.5	M8	54	10	6	CRA63	5
		345	365	39.5	19.5	M8	54	10.5	7	CRA63	6

\* Information about the roller type, see pg. CR-29, tab. 18

Tab. 10

CD-series

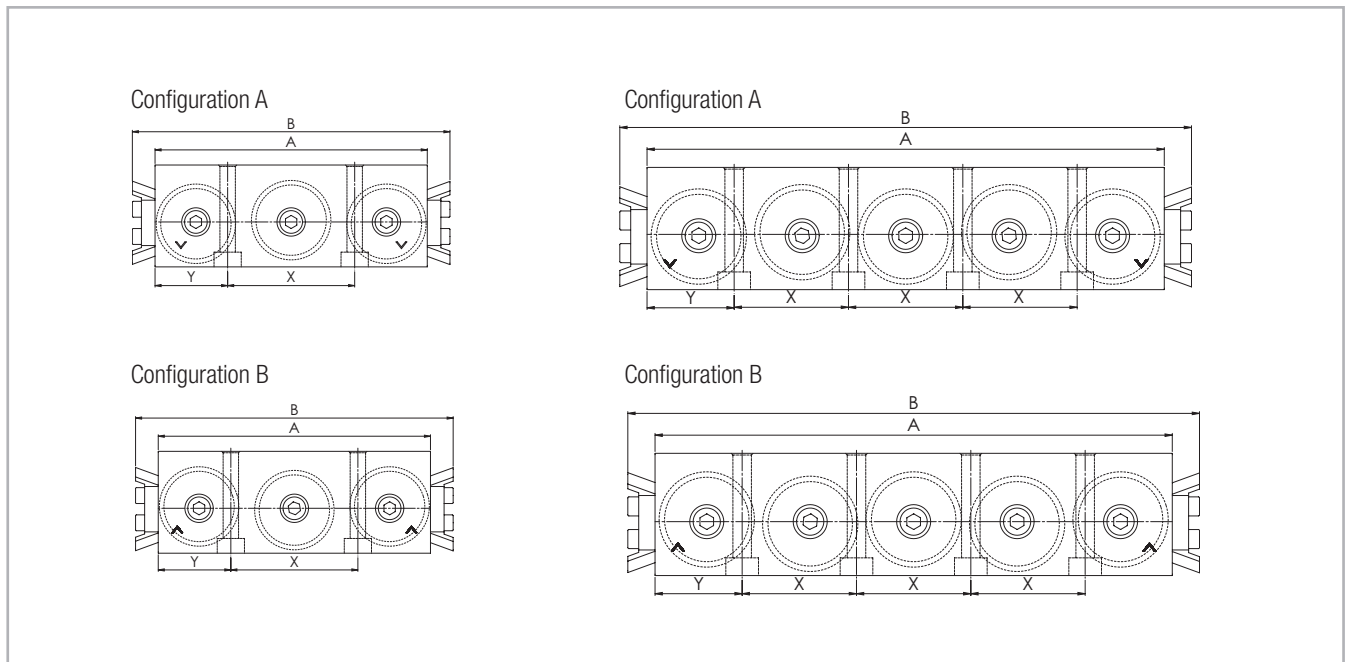

Representation of slider with wiper

Fig. 35

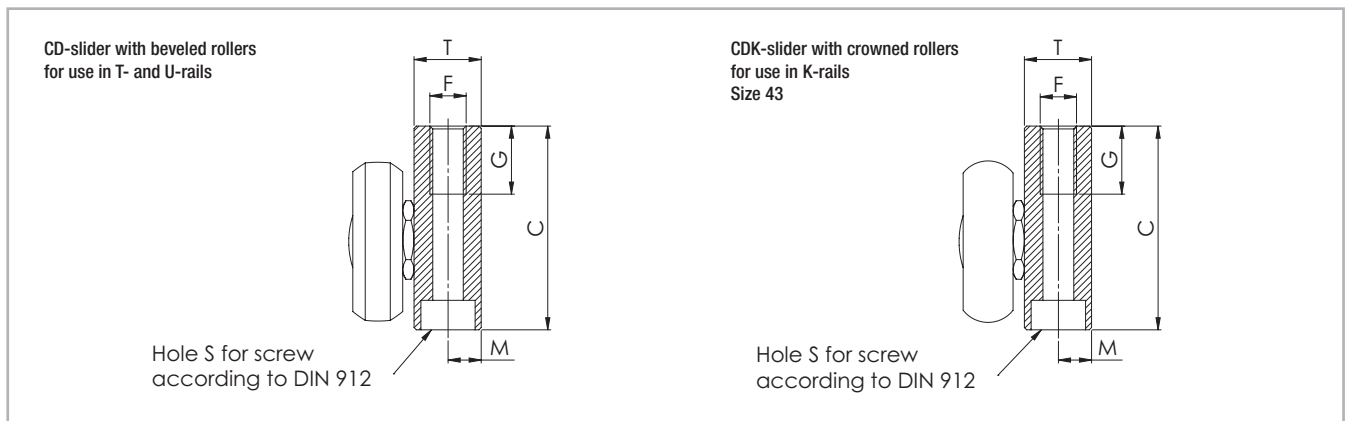

Fig. 36



Type	Size	A [mm]	B [mm]	C [mm]	T [mm]	M [mm]	S	G [mm]	F	X [mm]	Y [mm]	No. of holes	Roller type used*	Number of Rollers
CD	28	80	100	29.9	9.9	4.9	M5	15	M6	36	22	2	CPA28	3
		125	145	29.9	9.9	4.9	M5	15	M6	27	22	4	CPA28	5
	35	100	120	34.9	11.8	5.9	M6	15	M8	45	27.5	2	CPA35	3
		150	170	34.9	11.8	5.9	M6	15	M8	30	30	4	CPA35	5
	43	120	140	44.9	14.8	7.3	M6	15	M8	56	32	2	CPA43	3
		190	210	44.9	14.8	7.3	M6	15	M8	42	32	4	CPA43	5
CDK	43	120	140	44.9	14.8	7.3	M6	15	M8	56	32	2	CRA43	3
		190	210	44.9	14.8	7.3	M6	15	M8	42	32	4	CRA43	5

\* Information about the roller type, see pg. CR-29, tab. 18

Tab. 11

> T-rail with N- / C-slider

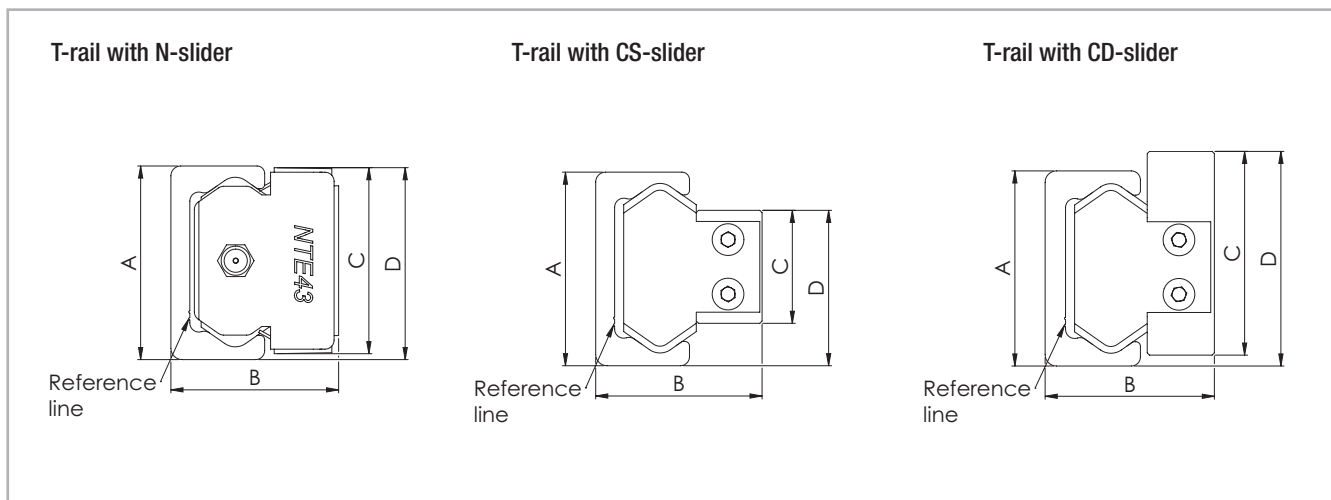

Fig. 37

Configuration	Size	A [mm]		B [mm]		C [mm]		D [mm]	
TL... / NT	18	18	+0.25 -0.10	16.5	+0.15 -0.15	17.6	0 -0.20	18.3	+0.25 -0.25
TL... / NTE	28	28	+0.25 -0.10	24	+0.25 -0.10	26.5	+0.10 -0.20	28	+0.15 -0.35
	43	43	+0.35 -0.10	37	+0.25 -0.10	40	0 -0.30	41.9	+0.20 -0.35
TL... / NTE...L	63	63	+0.35 -0.10	50.5	+0.25 -0.10	60	+0.10 -0.20	62	0 -0.50
	28	28	+0.25 -0.10	24	+0.25 -0.10	26.5	+0.10 -0.20	28	+0.15 -0.35
TL... / NTE...L	43	43	+0.35 -0.10	37	+0.25 -0.10	41	0 -0.30	42.4	+0.20 -0.35
	TL... / CS	18	18	+0.25 -0.10	15	+0.15 -0.15	9.5	0 -0.05	14
28		28	+0.25 -0.10	23.9	+0.15 -0.15	14.9	0 -0.10	21.7	+0.05 -0.35
35		35	+0.35 -0.10	30.2	+0.10 -0.30	19.9	+0.05 -0.15	27.85	+0.10 -0.30
43		43	+0.35 -0.10	37	+0.15 -0.15	24.9	0 -0.15	34.3	+0.10 -0.30
63		63	+0.35 -0.10	49.8	+0.15 -0.15	39.5	+0.15 0	51.6	+0.15 -0.30
TL... / CD	28	28	+0.25 -0.10	24.1	+0.20 -0.20	29.9	0 -0.50	32	+0.05 -0.35
	35	35	+0.35 -0.10	30.1	+0.20 -0.20	34.9	0 -0.50	37.85	+0.10 -0.30
	43	43	+0.35 -0.10	37.3	+0.20 -0.20	44.9	0 -0.50	47	+0.10 -0.30

Tab. 12

> TR-rail with N- / C-slider

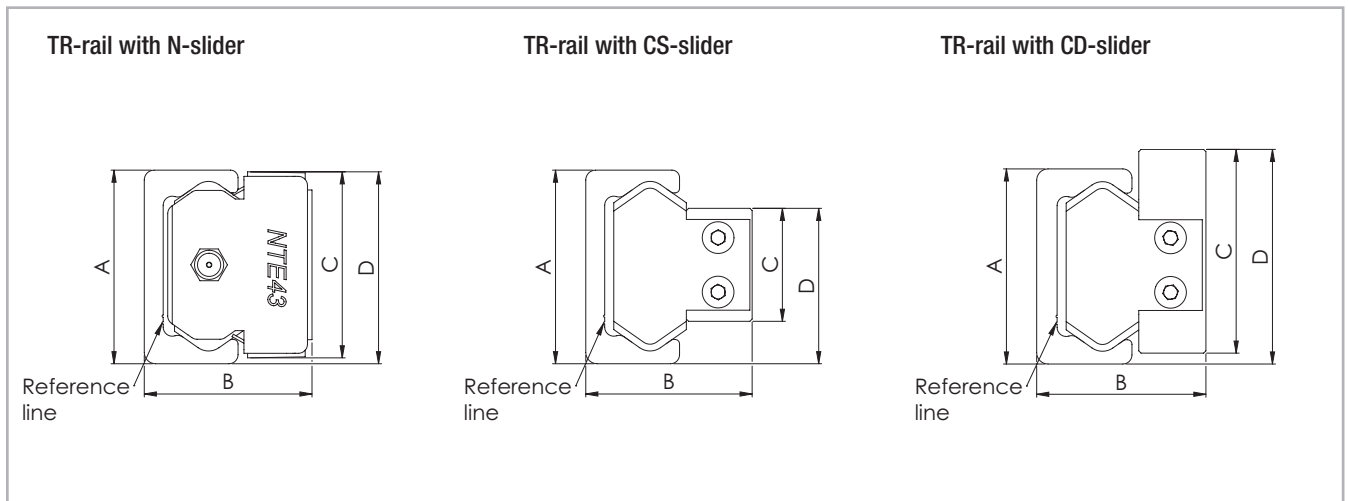

Fig. 38

Configuration	Size	A [mm]		B [mm]		C [mm]		D [mm]	
TR... / NT	18	17.95	+0.10 -0.05	16.4	+0.10 -0.05	17.6	0 -0.20	17.9	+0.15 -0.15
TR... / NTE	28	27.83	+0.10 -0.05	23.9	+0.15 -0.10	26.5	+0.10 -0.20	27.2	+0.15 -0.15
	43	42.75	+0.10 -0.05	36.9	+0.15 -0.10	40	0 -0.30	41.3	+0.15 -0.20
	63	62.8	+0.10 -0.05	50.4	+0.20 -0.10	60	+0.10 -0.30	61.3	+0.15 -0.20
TR... / NTE...L	28	27.83	+0.10 -0.05	23.9	+0.15 -0.10	26.5	+0.10 -0.20	27.2	+0.15 -0.15
	43	42.75	+0.10 -0.05	36.9	+0.15 -0.10	41	0 -0.30	41.8	+0.15 -0.20
TR... / CS	18	17.95	+0.10 -0.05	14.9	+0.10 -0.10	9.5	0 -0.05	13.8	+0.15 -0.15
	28	27.83	+0.10 -0.05	23.8	+0.10 -0.10	14.9	0 -0.10	21.3	+0.10 -0.20
	35	34.75	+0.10 -0.05	30.1	+0.10 -0.30	19.9	+0,05 -0.15	27.35	+0.10 -0.20
	43	42.75	+0.10 -0.05	36.9	+0.15 -0.10	24.9	0 -0.15	33.5	+0.10 -0.20
	63	62.8	+0.10 -0.05	49.7	+0.10 -0.15	39.5	+0.15 0	51.05	+0.15 -0.10
TR... / CD	28	27.83	+0.10 -0.05	24	+0.10 -0.20	29.9	0 -0.50	31.63	+0.10 -0.20
	35	34.75	+0.10 -0.05	30	+0.10 -0.20	34.9	0 -0.50	37.35	+0.10 -0.20
	43	42.75	+0.10 -0.05	37.2	+0.10 -0.20	44.9	0 -0.50	46.4	+0.10 -0.20

Tab. 13

> U-rail with N- / C-slider

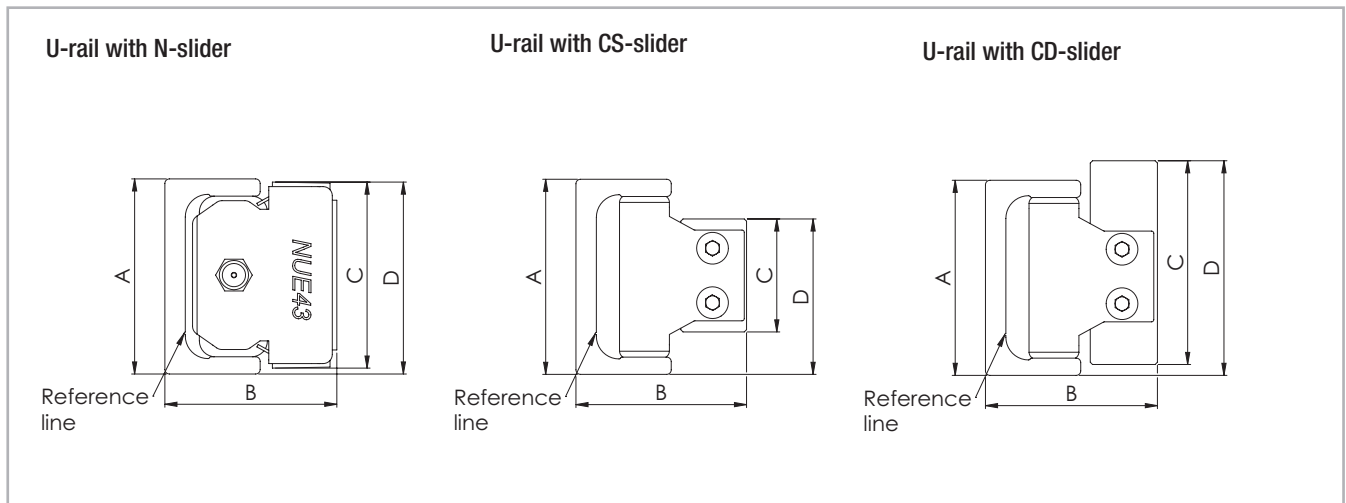

Fig. 39

Configuration	Size	A [mm]		B <sub>nom*</sub> [mm]	C [mm]		D [mm]	
UL... / NU	18	18	+0.25 -0.10	16.5	17.6	0 -0.20	18.3	+0.25 -0.25
UL... / NUE	28	28	+0.25 -0.10	24	26.5	0 -0.20	28	+0.15 -0.35
	43	43	+0.35 -0.10	37	40	0 -0.30	41.9	+0.20 -0.30
	63	63	+0.35 -0.10	50.5	60	-0.20	62	0 -0.50
UL... / NUE...L	28	28	+0.25 -0.10	24	26.5	0 -0.20	28	+0.15 -0.35
	43	43	+0.35 -0.10	37	41	0 -0.30	42.4	+0.20 -0.35
UL... / CS	18	18	+0.25 -0.10	15	9.5	0 -0.05	14	+0.05 -0.25
	28	28	+0.25 -0.10	23.9	14.9	0 -0.10	21.7	+0.05 -0.35
	35	35	+0.35 -0.10	30.2	19.9	+0.05 -0.15	27.85	+0.10 -0.30
	43	43	+0.35 -0.10	37	24.9	0 -0.15	34.3	+0.15 -0.30
	63	63	+0.35 -0.10	49.8	39.5	+0.15 0	51.6	+0.15 -0.30
UL... / CD	28	28	+0.25 -0.10	24.1	29.9	0 -0.50	32	+0.05 -0.35
	35	35	+0.35 -0.10	30.1	34.9	0 -0.50	37.85	+0.10 -0.30
	43	43	+0.35 -0.10	37.3	44.9	0 -0.50	47	+0.10 -0.30

\* see pg. CR-40 Offset T+U-system  
see pg. CR-43 Offset K+U-system

Tab. 14

> K-rail with N- / C-slider

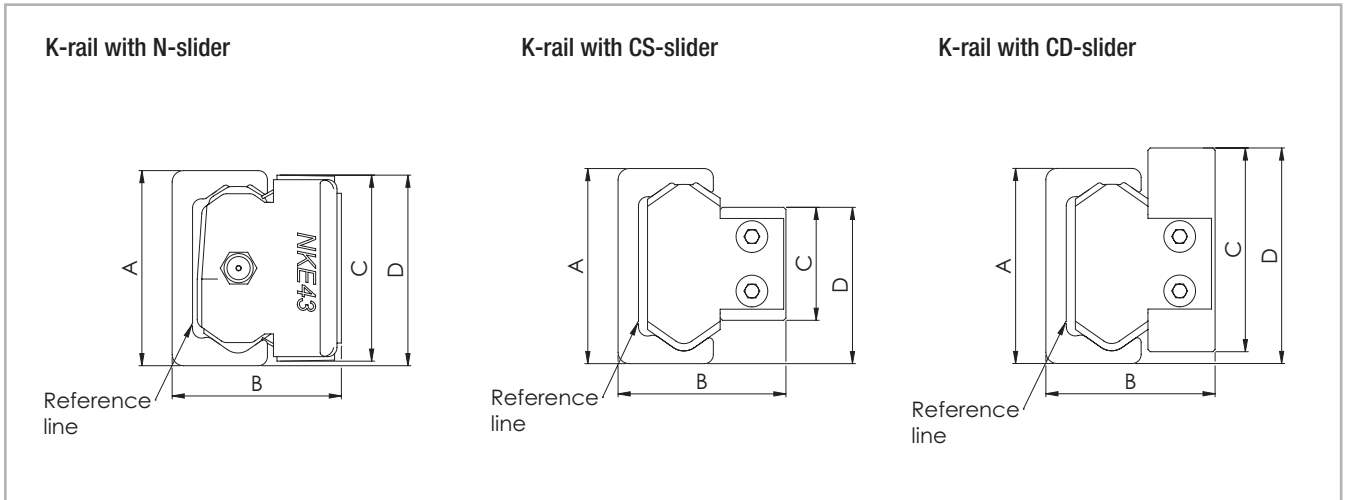

The K-rail enables the slider to rotate around its longitudinal axis (see pg. CR-42)

Fig. 40

Configuration	Size	A [mm]		B [mm]		C [mm]		D [mm]	
KL... / NKE	43	43	+0.35 -0.10	37	+0.25 -0.10	40	0 -0.30	41.9	+0.20 -0.35
	63	63	+0.35 -0.10	50.5	+0.25 -0.10	60	+0.10 -0.20	62	0 -0.50
KL... / NKE...L	43	43	+0.35 -0.10	37	+0.25 -0.10	41	0 -0.30	42.7	+0.20 -0.35
KL... / CSK	43	43	+0.35 -0.10	37	+0.15 -0.15	24.9	0 -0.15	34.3	+0.10 -0.30
	63	63	+0.35 -0.10	49.8	+0.15 -0.15	39.5	+0.15 0	51.6	+0.15 -0.30
KL... / CDK	43	43	+0.35 -0.10	37.3	+0.20 -0.20	44.9	0 -0.50	47	+0.10 -0.30

Tab. 15

> Offset of fixing holes

Principle representation of offset with T-rails



Fig. 41

Configura-tion	Size	δ nominal [mm]	δ maximum [mm]	δ minimum [mm]
TLC / NT	18	0.45	0.95	-0.25
TLC / NTE	28	0.35	0.85	-0.4
	43	0.35	0.9	-0.5
	63	0.35	0.8	-0.55
KLC / NKE	43	0.35	0.9	-0.5
	63	0.35	0.8	-0.55
ULC / NU	18	0.4	0.9	-0.25
ULC / NUE	28	0.4	0.85	-0.3
	43	0.4	0.85	-0.45
	63	0.35	0.8	-0.45
TLV / NT	18	0.45	0.8	-0.2
TLV / NTE	28	0.35	0.7	-0.35
	43	0.35	0.75	-0.45
	63	0.35	0.65	-0.55
KLV / NKE	43	0.35	0.75	-0.45
	63	0.35	0.65	-0.55
ULV / NU	18	0.4	0.75	-0.2
ULV / NUE	28	0.4	0.7	-0.25
	43	0.4	0.7	-0.4
	63	0.35	0.65	-0.45
TLC / CS	18	0.35	0.75	-0.2
	28	0.25	0.6	-0.35
	35	0.35	0.7	-0.35
	43	0.35	0.8	-0.35
	63	0.35	0.6	-0.35
KLC / CSK	43	0.35	0.8	-0.35
	63	0.35	0.6	-0.35

Tab. 16

Configura-tion	Size	δ nominal [mm]	δ maximum [mm]	δ minimum [mm]
ULC / CS	18	0.3	0.7	-0.2
	28	0.3	0.6	-0.3
	35	0.35	0.7	-0.35
	43	0.4	0.75	-0.35
	63	0.35	0.6	-0.25
TLV / CS	18	0.35	0.6	-0.15
	28	0.25	0.45	-0.3
	35	0.35	0.55	-0.3
	43	0.35	0.65	-0.3
	63	0.35	0.45	-0.35
KLV / CSK	43	0.35	0.65	-0.3
	63	0.35	0.45	-0.35
ULV / CS	18	0.3	0.55	-0.15
	28	0.3	0.45	-0.25
	35	0.35	0.55	-0.3
	43	0.4	0.6	-0.3
	63	0.35	0.45	-0.25
TRC / NT	18	0.15	0.65	-0.2
TRC / NTE	28	0.15	-0.5	-0.25
	43	0.05	0.4	-0.3
	63	0	0.4	-0.4
TRC / CS	18	0.05	0.45	-0.2
	28	0.05	0.3	-0.25
	35	0.1	0.35	-0.2
	43	0.05	0.35	-0.25
	63	0	0.2	-0.2

Tab. 17

# Accessories



## > Rollers

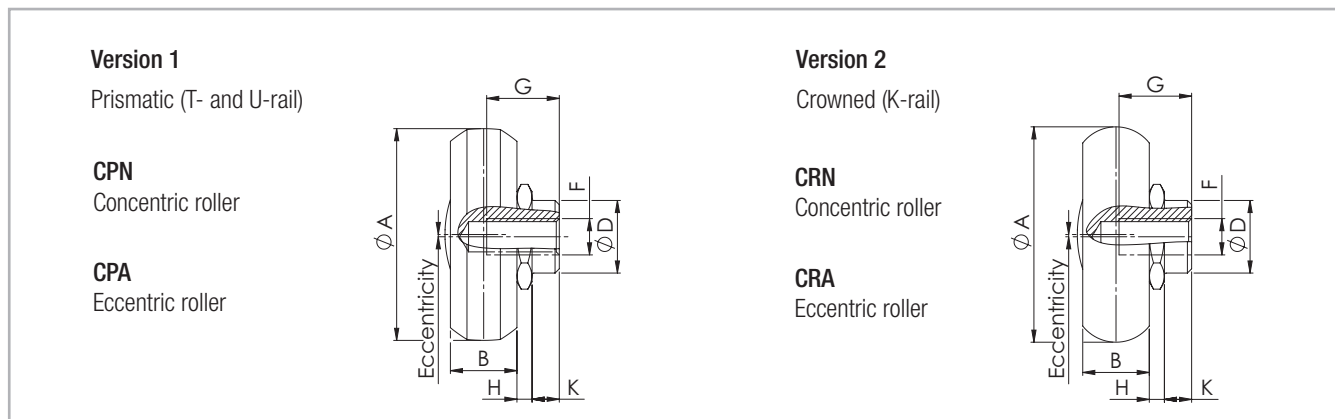

Seals: 2RS is the splash-proof seal, 2Z (2ZR for size 63) is the steel cover disc  
Note: The rollers are lubricated for life

Fig. 42

Type	A [mm]	B [mm]	D [mm]	e [mm]	H [mm]	K [mm]	G [mm]	F	C [N]	C <sub>Orad</sub> [N]	Weight [kg]
CPN18-2RS	14	4	6	-	1.55	1.8	5.5	M4	765	410	0.004
CPN18-2Z	14	4	6	-	1.55	1.8	5.5	M4	765	410	0.004
CPA18-2RS	14	4	6	0.4	1.55	1.8	5.5	M4	765	410	0.004
CPA18-2Z	14	4	6	0.4	1.55	1.8	5.5	M4	765	410	0.004
CPN28-2RS	23.2	7	10	-	2.2	3.8	7	M5	2130	1085	0.019
CPN28-2Z	23.2	7	10	-	2.2	3.8	7	M5	2130	1085	0.019
CPA28-2RS	23.2	7	10	0.6	2.2	3.8	7	M5	2130	1085	0.019
CPA28-2Z	23.2	7	10	0.6	2.2	3.8	7	M5	2130	1085	0.019
CPN35-2RS	28.2	7.5	12	-	2.55	4.2	9	M5	4020	1755	0.032
CPN35-2Z	28.2	7.5	12	-	2.55	4.2	9	M5	4020	1755	0.032
CPA35-2RS	28.2	7.5	12	0.7	2.55	4.2	9	M5	4020	1755	0.032
CPA35-2Z	28.2	7.5	12	0.7	2.55	4.2	9	M5	4020	1755	0.032
CPN43-2RS	35	11	12	-	2.5	4.5	12	M6	6140	2750	0.06
CPN43-2Z	35	11	12	-	2.5	4.5	12	M6	6140	2750	0.06
CPA43-2RS	35	11	12	0.8	2.5	4.5	12	M6	6140	2750	0.06
CPA43-2Z	35	11	12	0.8	2.5	4.5	12	M6	6140	2750	0.06
CPN63-2ZR	50	17.5	18	-	2.3	6	16	M8	15375	6250	0.19
CPA63-2ZR	50	17.5	18	1.2	2.3	6	16	M10	15375	6250	0.19
CRN43-2Z	35.6	11	12	-	2.5	4.5	12	M6	6140	2550	0.06
CRA43-2Z	35.6	11	12	0.8	2.5	4.5	12	M6	6140	2550	0.06
CRN63-2ZR	49.7	17.5	18	-	2.3	6	16	M8	15375	5775	0.19
CRA63-2ZR	49.7	17.5	18	1.2	2.3	6	16	M10	15375	5775	0.19

Tab. 18

> Wipers for C-slider

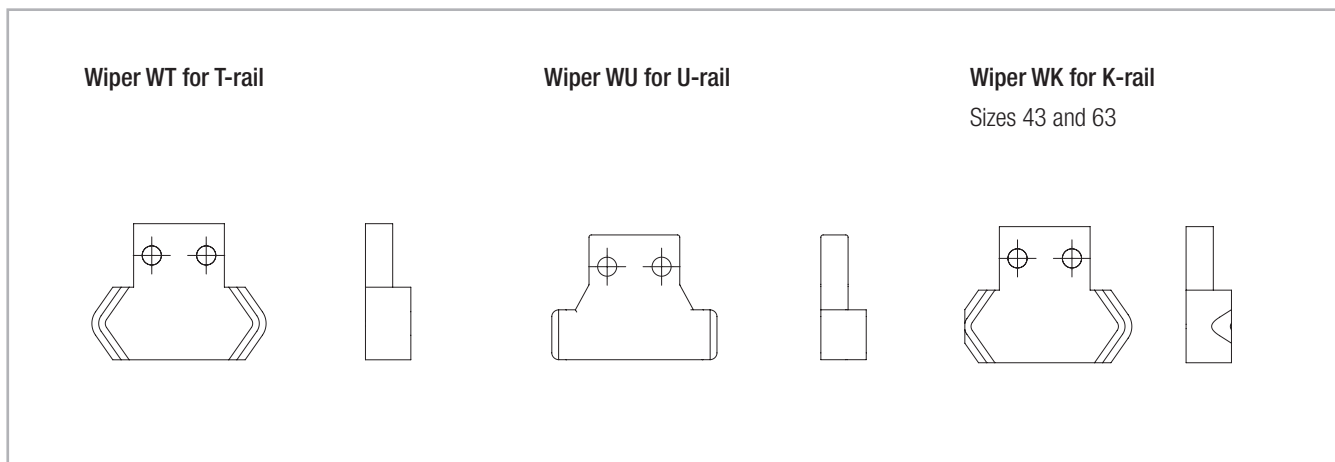

Fig. 43

> Alignment fixture AT (for T- and U-rail)

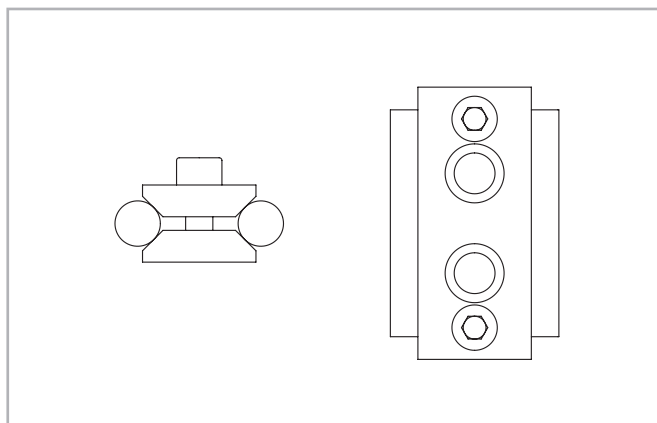

Fig. 44

Rail size	Alignment fixture
18	AT 18
28	AT 28
35	AT 35
43	AT 43
63	AT 63

Tab. 19

> Alignment fixture AK (for K-rail)

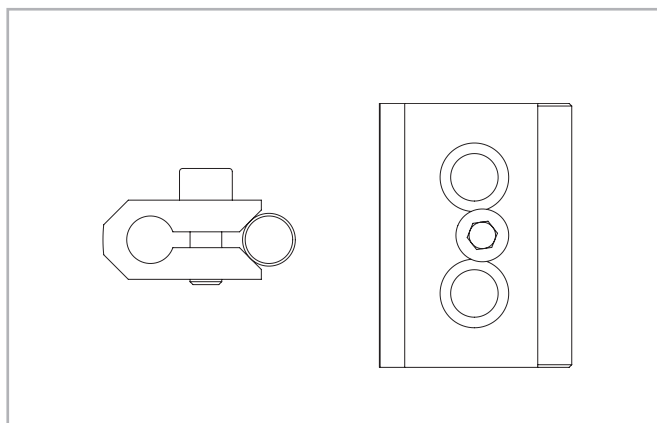

Fig. 45

Rail size	Alignment fixture
43	AK 43
63	AK 63

Tab. 20



> Fixing screws

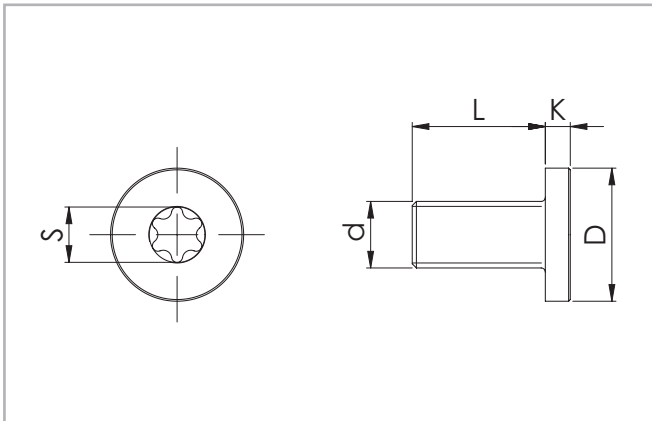

Fig. 46

Rail size	d	D [mm]	L [mm]	K [mm]	S	Tightening torque [Nm]
18	M4 x 0.7	8	8	2	T20	3
28	M5 x 0.8	10	10	2	T25	9
35	M6 x 1	13	13	2,7	T30	12
43	M8 x 1.25	16	16	3	T40	22
63	M8 x 1.25	13	20	5	T40	35

Tab. 21

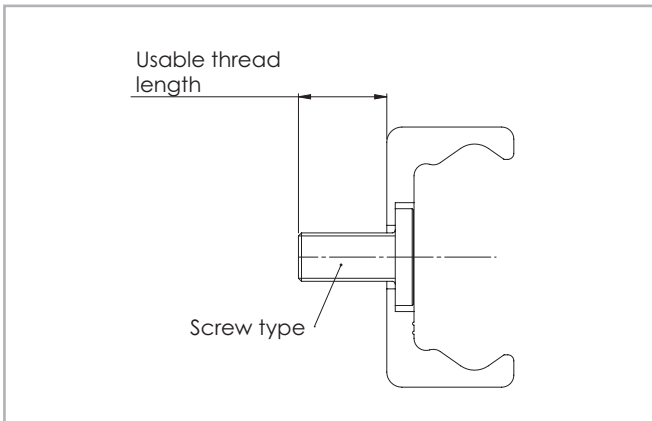

Fig. 47

Rail size	Screw type	Usable thread length [mm]
18	M4 x 8	7.2
28	M5 x 10	9
35	M6 x 13	12.2
43	M8 x 16	14.6
63	M8 x 20	17.2

Tab. 22

## > Manual clamp elements

Compact Rail guides can be secured with manual clamping elements. Areas of application are:

- Table cross beams and sliding beds
- Width adjustment, stops
- Positioning of optical equipment and measuring tables

The HK series is a manually activated clamping element. By using the freely adjustable clamping lever (except for HK 18, which uses hexagon socket bolt M6 DIN 913 with 3 mm drive) press the contact profile synchronously on the free surfaces of the rail. The floating mounted contact profiles guarantee symmetrical introduction of force on the guide rail.

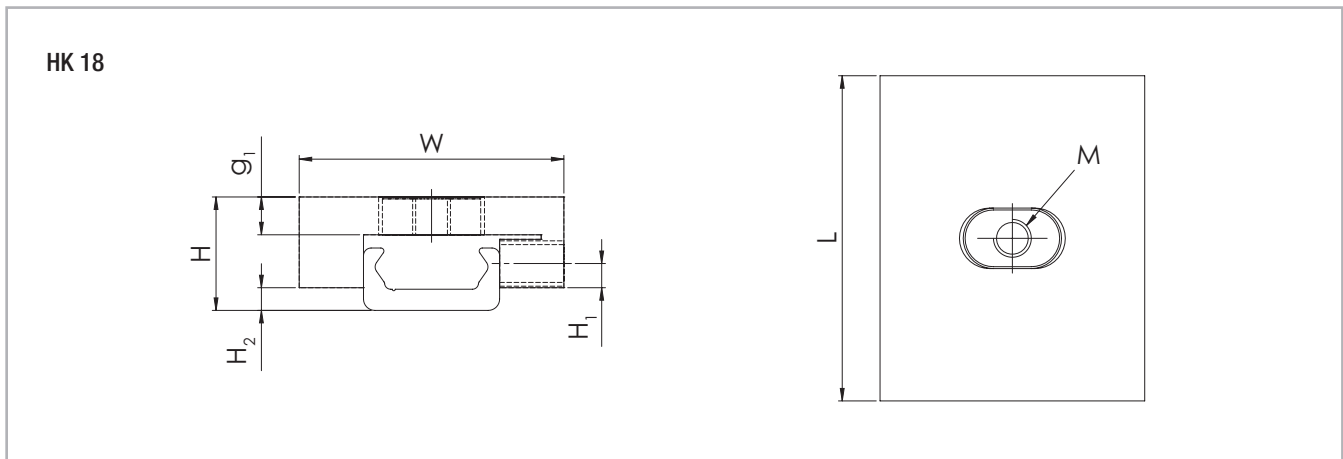

Fig. 48

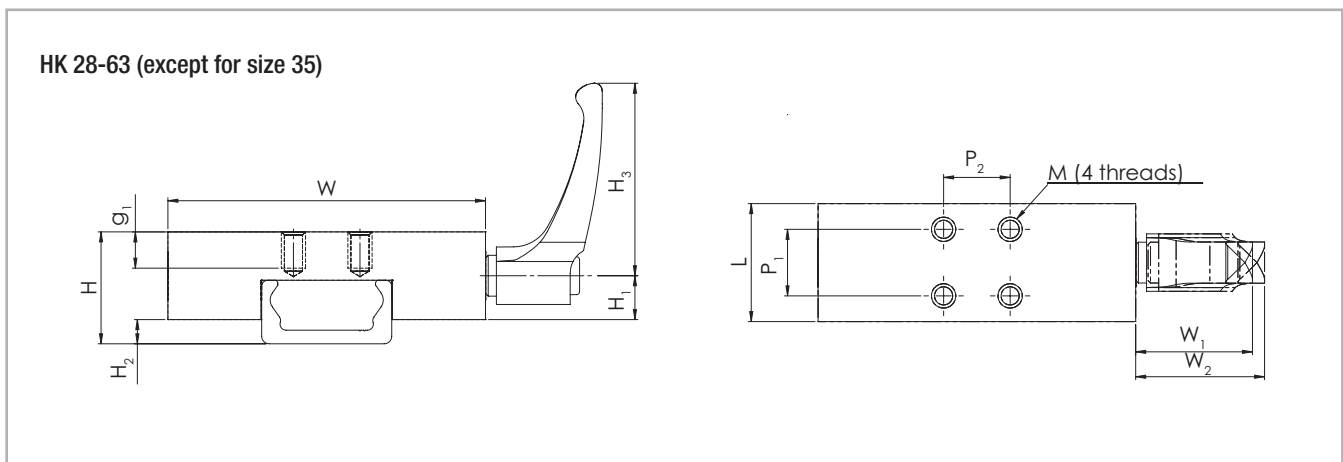

Fig. 49

Type	Size	Holding force [N]	Tightening torque [Nm]	Dimensions [mm]											M
				H	H <sub>1</sub>	H <sub>2</sub>	H <sub>3</sub>	W	W <sub>1</sub>	W <sub>2</sub>	L	P <sub>1</sub>	P <sub>2</sub>	g <sub>1</sub>	
HK1808A	18	150	0.5	15	3.2	3	-	35	-	-	43	0	0	6	M5
HK2808A	28	1200	7	24	17	5	64	68	38.5	41.5	24	15	15	6	M5
HK4308A	43	2000	15	37	28.5	8	78	105	46.5	50.5	39	22	22	12	M8
HK6308A	63	2000	15	50.5	35	9.5	80	138	54.5	59.5	44	26	26	12	M8

Tab. 23

# Technical instructions

## > Linear accuracy

Linear accuracy is defined as the maximum deviation of the slider in the rail based on the side and support surface during straight line movement.

The linear accuracy, depicted in the graphs below, applies to rails that are carefully installed with all the provided screws on a level and rigid foundation.

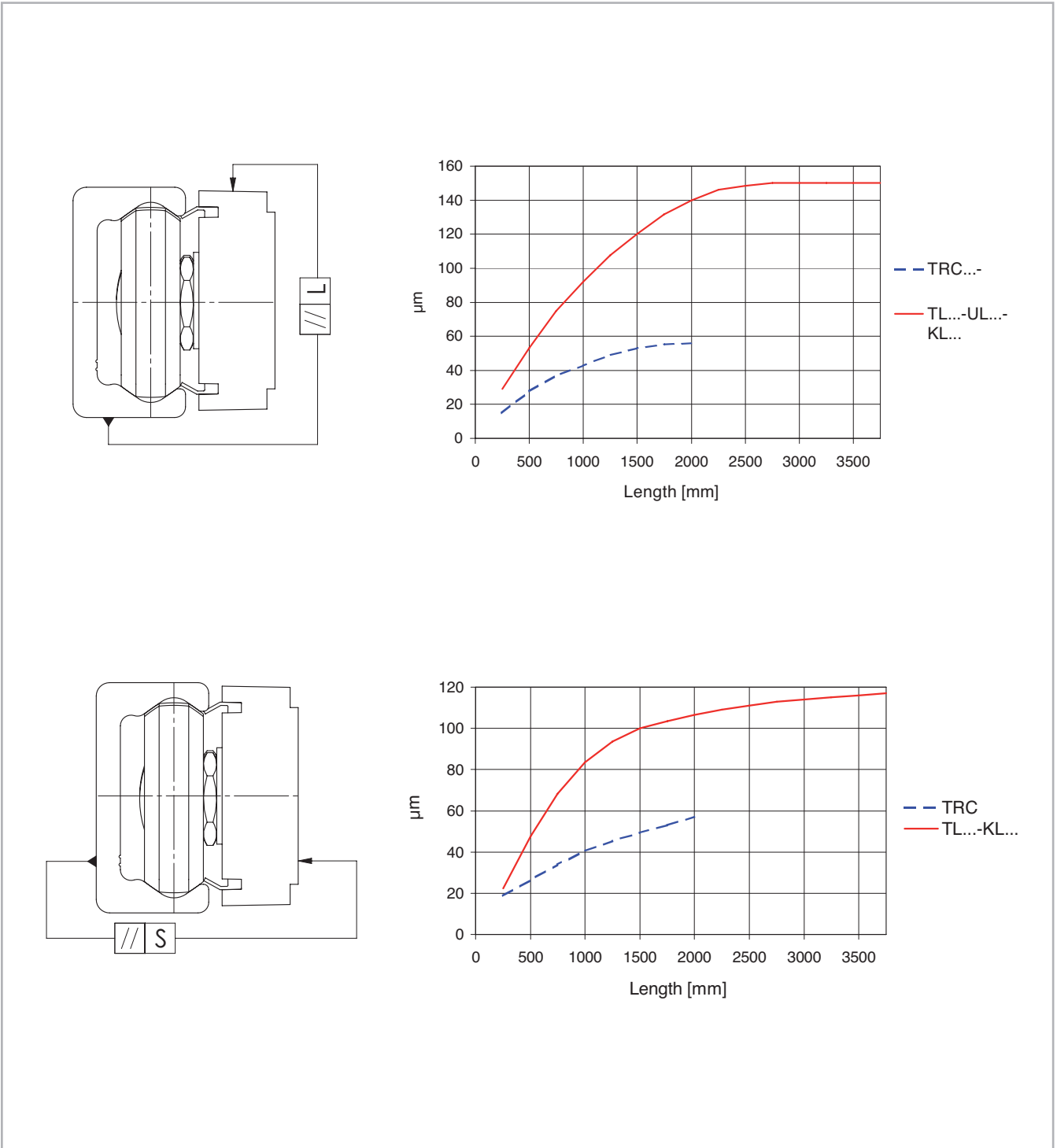
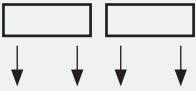
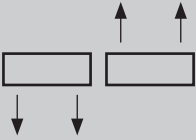

Fig. 50

C  
R

## Deviation of accuracy with two 3 roller sliders in one rail

Type	TL..., UL..., KL... TRC
$\Delta L$ [mm] Slider with equal arrangement 	0.2
$\Delta L$ [mm] Slider with opposite arrangement 	1.0
$\Delta S$ [mm]	0.05

Tab. 24

## > Rigidity

### Total deformation

In the following deformation diagrams the total deviation of the linear guide is indicated under the effect of external loads P or moments M. As seen from the graphs, the rigidity can be increased by supporting the sides of the rails. The graph values indicate only the deformation of the

linear guide, the supporting structure is assumed infinitely rigid. All graphs refer to sliders with 3 rollers and K1 preload (standard setting). An increased preload, K2, reduces the deformation values by 25 %.

### Size 18 - 43

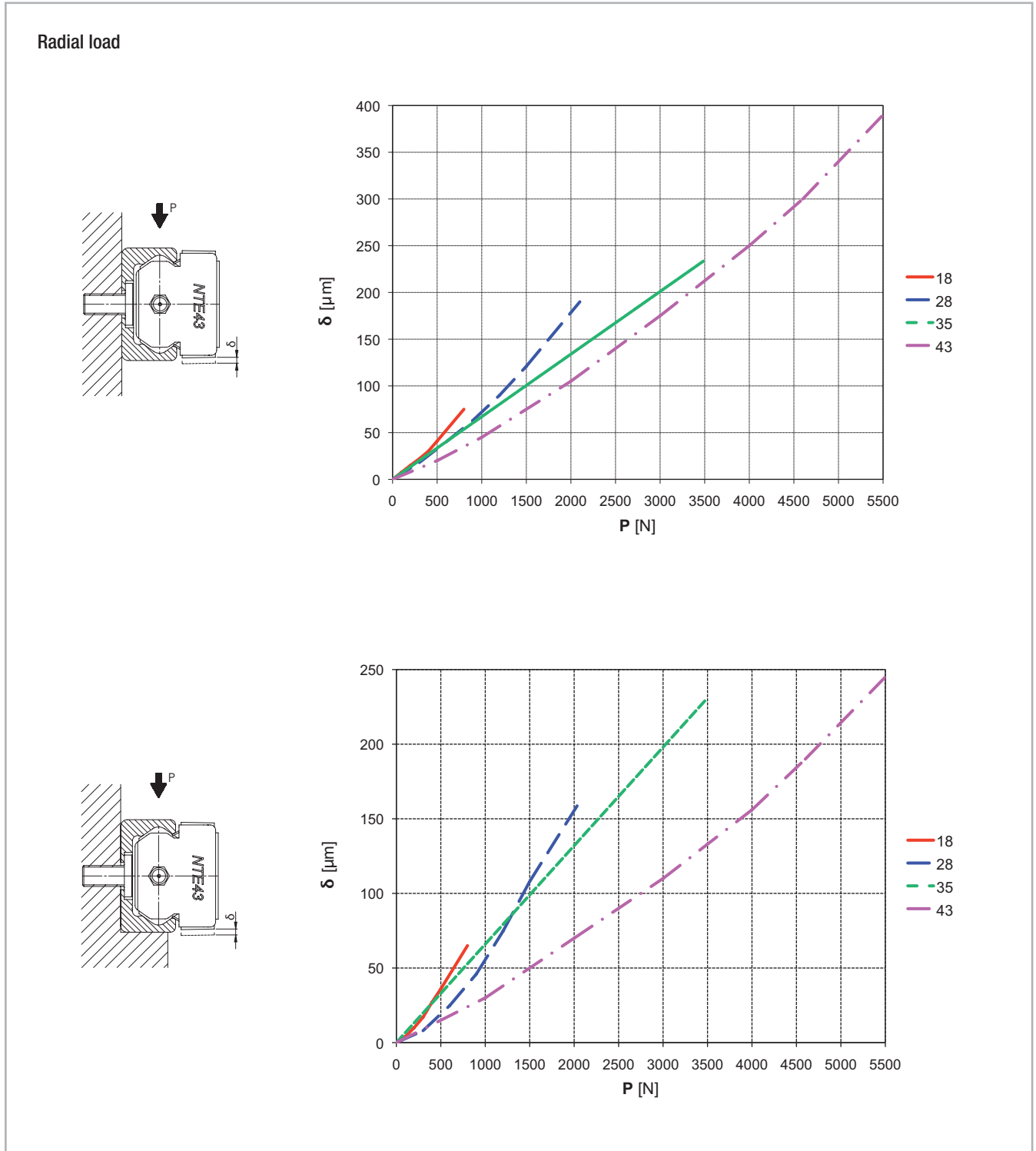
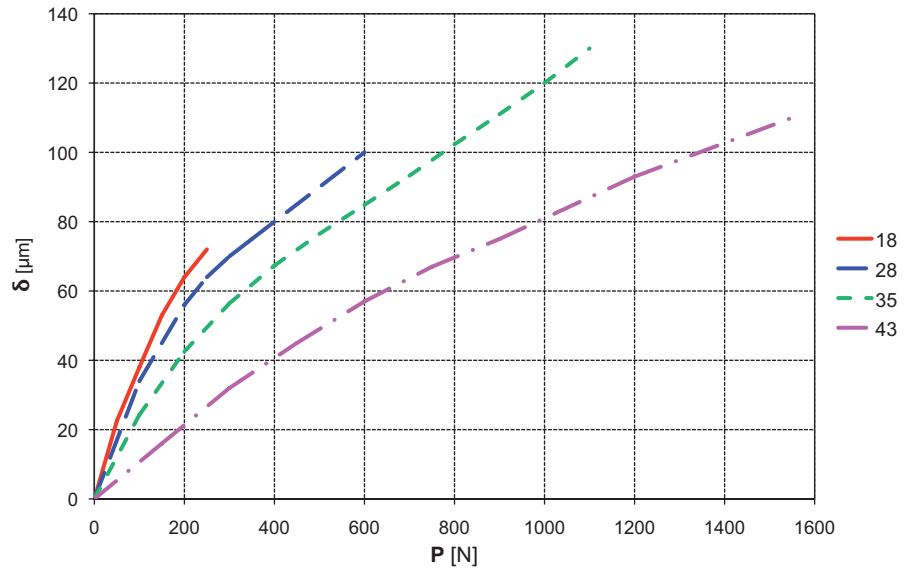
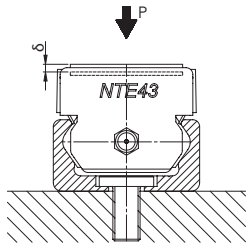

Fig. 51

Axial load



Moment Mx

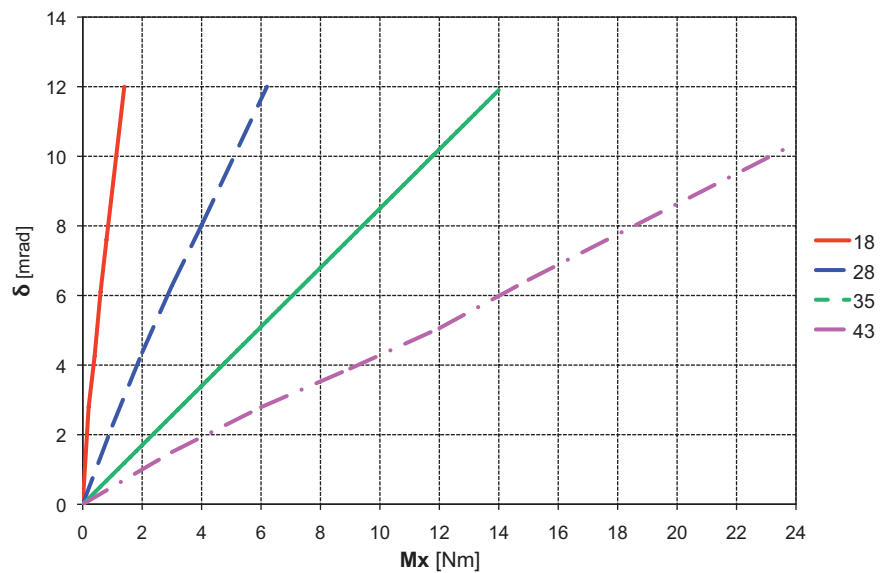
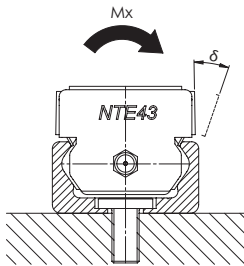

Fig. 52

Size 63

Radial load

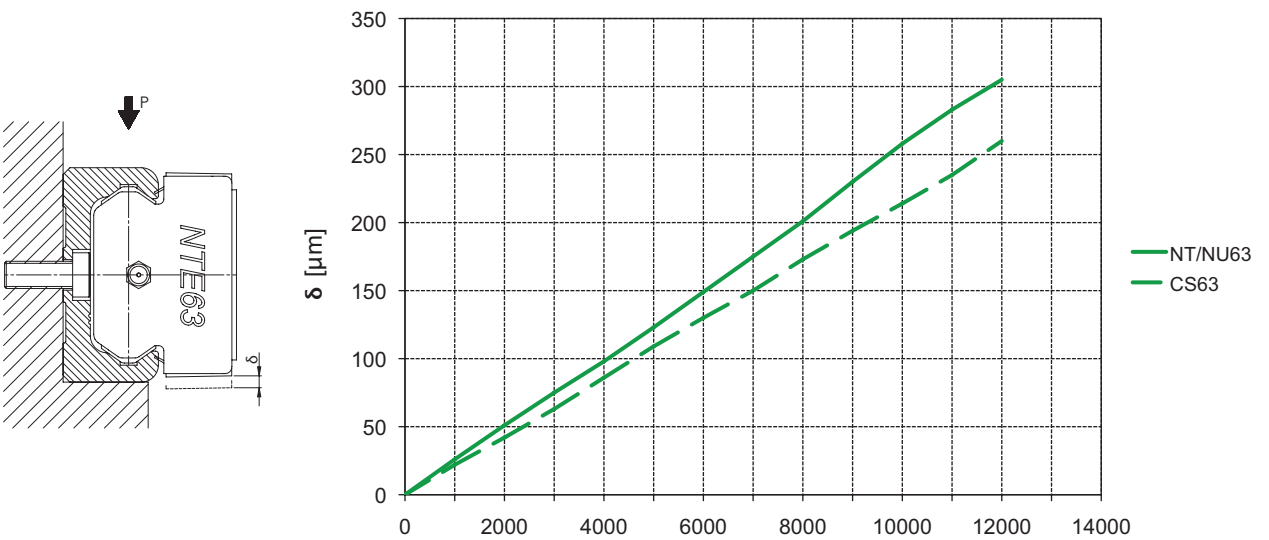
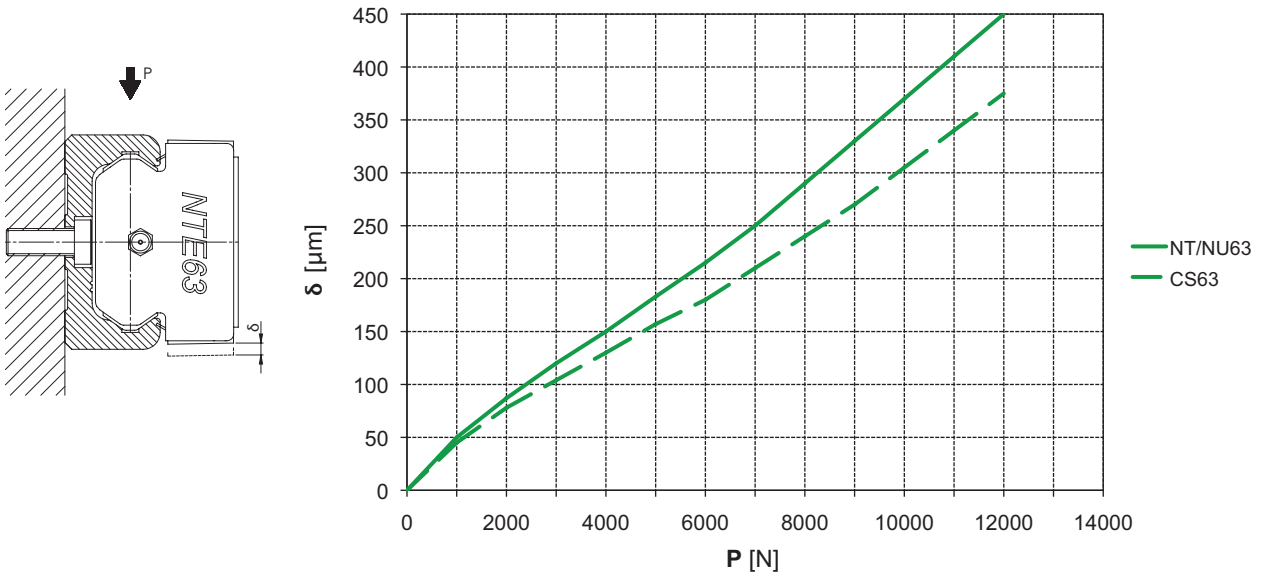
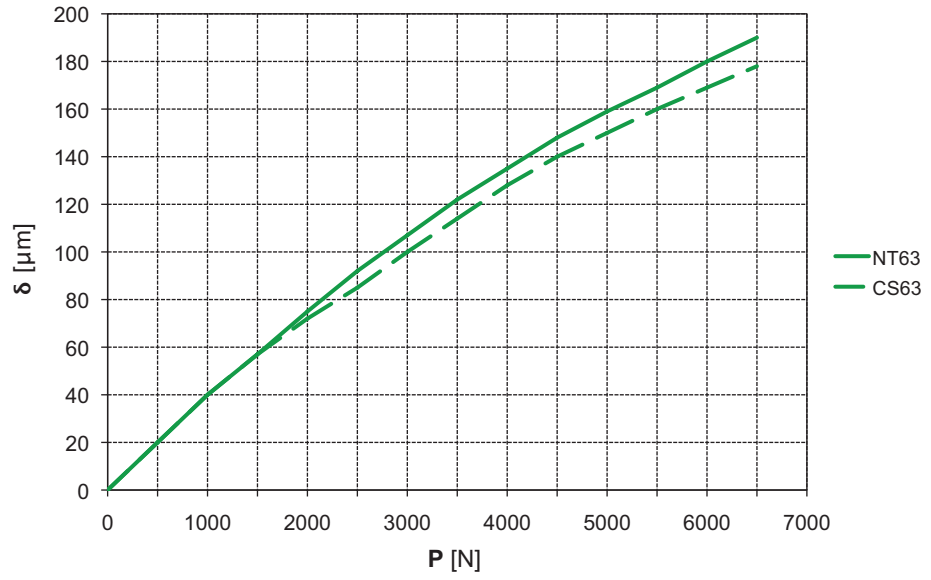
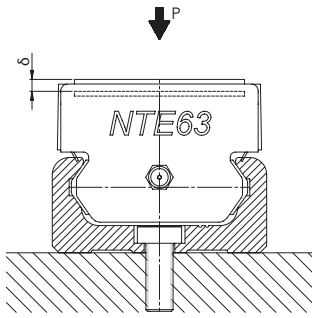

Fig. 53

Axial load



Moment  $M_x$

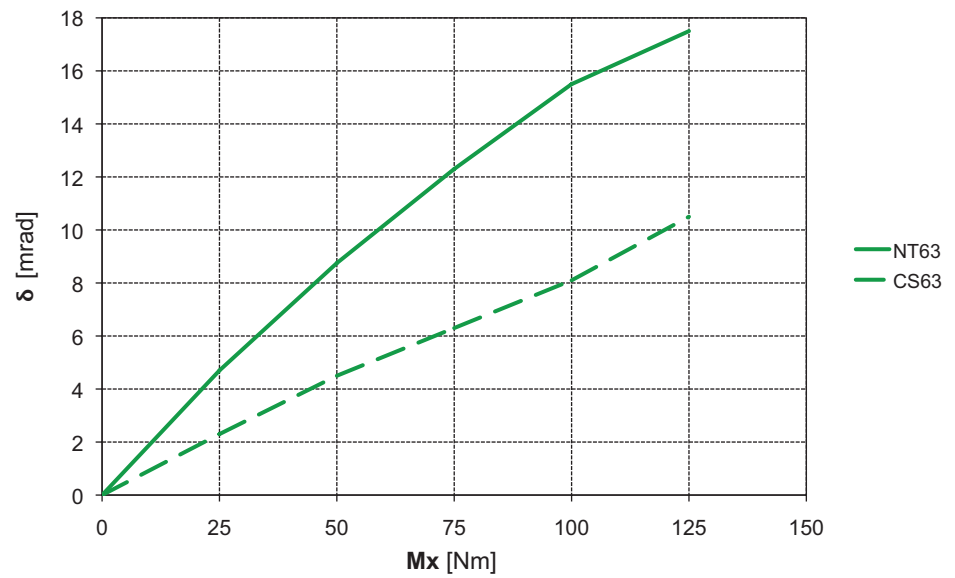
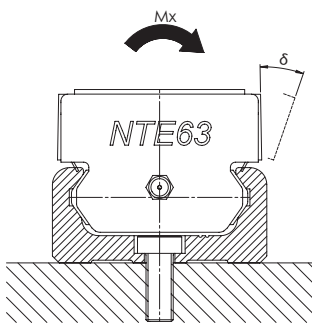

Fig. 54



### > Supported sides

If a higher system rigidity is required, a support of the rail sides is recommended, which can also be used as the reference surface (see fig. 55). The minimum required support depth can be taken from the adjacent table (see tab. 25).

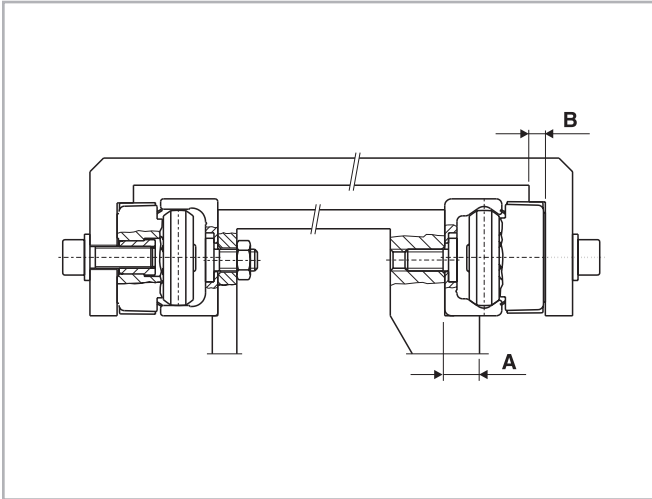

Fig. 55

Rail size	A [mm]	B [mm]
18	5	4
28	8	4
35	11	5
43	14	5
63	18	5

Tab. 25

## > T+U-system tolerance compensation

### Axial deviations in parallelism

This problem occurs fundamentally by insufficient precision in the axial parallelism of the mounting surfaces, which results in an excessive load on the slider and thus causes drastically reduced service life.

The use of fixed bearing and compensating bearing rail (T+U-system) solves the unique problem of aligning two track, parallel guide systems. By using a T+U-system, the T-rail takes over the motion of the track while the U-rail serves as a support bearing and takes only radial forces and  $M_z$  moments.

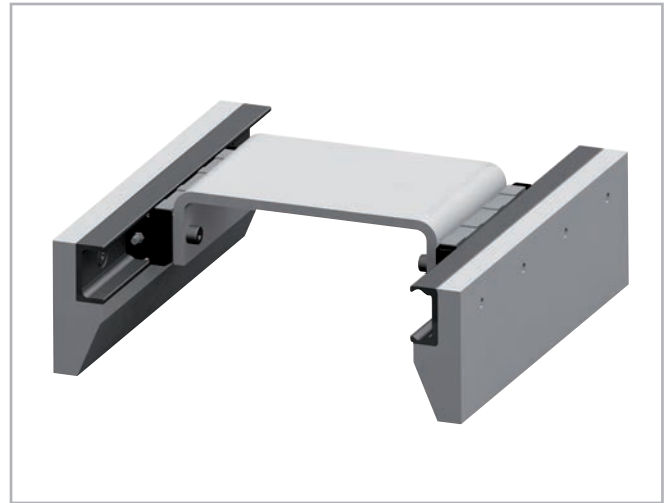

Fig. 56

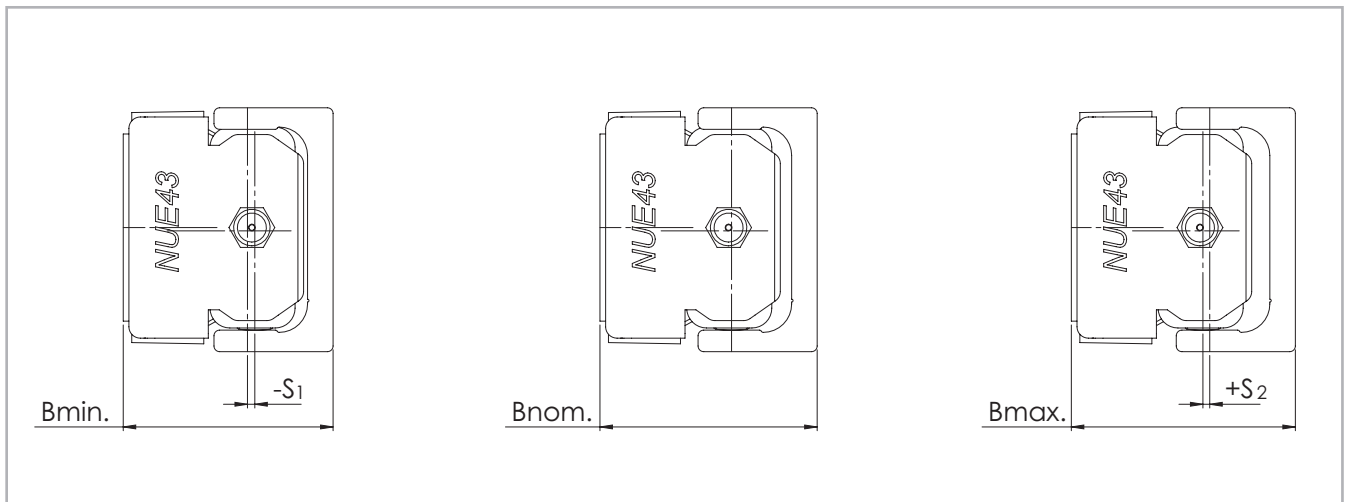

Fig. 57

### T+U-system maximum offset

U-rails have flat parallel raceways that allow free lateral movement of the sliders. The maximum axial offset that can be compensated for in each slider of the U-rail is made up of the combined values  $S_1$  and  $S_2$  listed in table 26. Considered from a nominal value  $B_{nom}$  as the starting point,  $S_1$  indicates the maximum offset into the rail, while  $S_2$  represents the maximum offset towards the outside of the rail.

Slider type	$S_1$ [mm]	$S_2$ [mm]	$B_{min}$ [mm]	$B_{nom}$ [mm]	$B_{max}$ [mm]
NU18	0	1.1	16.5	16.5	17.6
CS18	0.3	1.1	14.7	15	16.1
NUE28 NUE28L	0	1.3	24	24	25.3
CS28 CD28	0.6	1.3	23.3	23.9	25.2
CS35	1.3	2.7	28.9	30.2	32.9
CD35	1.3	2.7	28.8	30.1	32.8
NUE43 NUE43L	0	2.5	37	37	39.5
CS43	1.4	2.5	35.6	37	39.5
CD43	1.4	2.5	35.9	37.3	39.8
NUE63	0	3.5	50.5	50.5	54
CS63	0.4	3.5	49.4	49.8	53.3

Tab. 26

The application example in the adjacent drawing (see fig. 59) shows that the T+U-system implements a problem-free function of the slider even with an angled offset in the mounting surfaces.

If the length of the guide rails is known, the maximum allowable angle deviation of the screwed surfaces can be determined using this formula (the slider in the U-rail moves here from the innermost position  $S_1$  to outermost position  $S_2$ ):

$\alpha = \arctan \frac{S^*}{L}$	$S^* = \text{Sum of } S_1 \text{ and } S_2$ $L = \text{Length of rail}$
----------------------------------	--

Fig. 58

The following table (tab. 27) contains guidelines for this maximum angle deviation  $\alpha$ , achievable with the longest guide rail from one piece.

Size	Rail length [mm]	Offset S [mm]	Angle $\alpha$ [°]
18	2000	1.4	0.040
28	3200	1.9	0.034
35	3600	4	0.063
43	3600	3.9	0.062
63	3600	3.9	0.062

Tab. 27

The T+U-system can be designed in different arrangements (see fig. 60). A T-rail accepts the vertical components of load P. A U-rail attached underneath the component to be guided prevents the vertical panel from swinging and is used as moment support. In addition a vertical offset in the structure, as well as possible existing unevenness of the support surface, is compensated for.

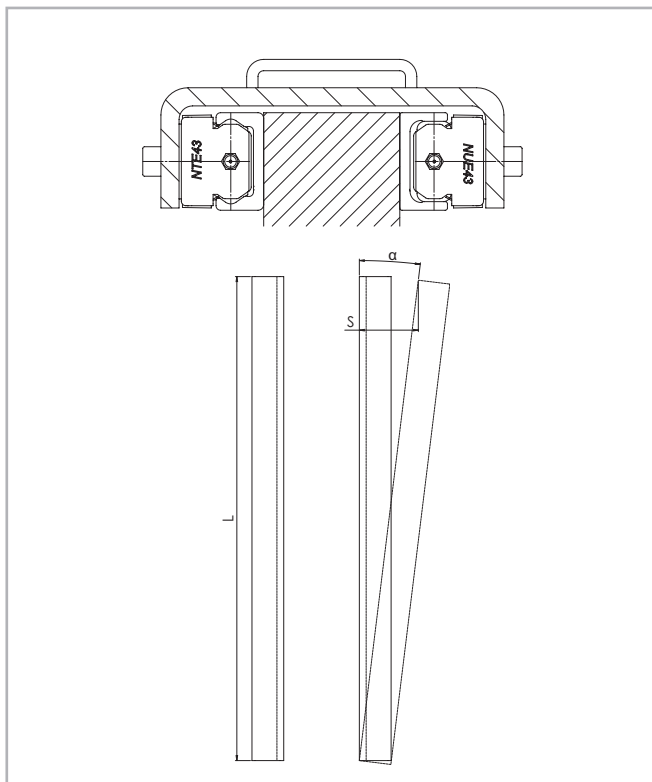

Fig. 59



Fig. 60

## > K+U-system tolerance compensation

### Deviations in parallelism in two planes

The K+U-system, like the T+U-system, can compensate for axial deviations in parallelism. Additionally, the K+U system has the option of rotating the slider in the rail, which will compensate for other deviations in parallelism, e.g. height offset.

The unique raceway contour of the K-rail allows the slider a certain rotation around its longitudinal axis, with the same linear precision as with a T-rail. With the use of a K+U-system, the K-rail accounts for the main loads and the motion of the track. The U-rail is used as a support bearing and takes only radial forces and  $M_z$  moments. The K-rail must always be installed so that the radial load of the slider is always supported by at least 2 load bearing roller sliders, which lie on the V-shaped raceway (reference line) of the rail.

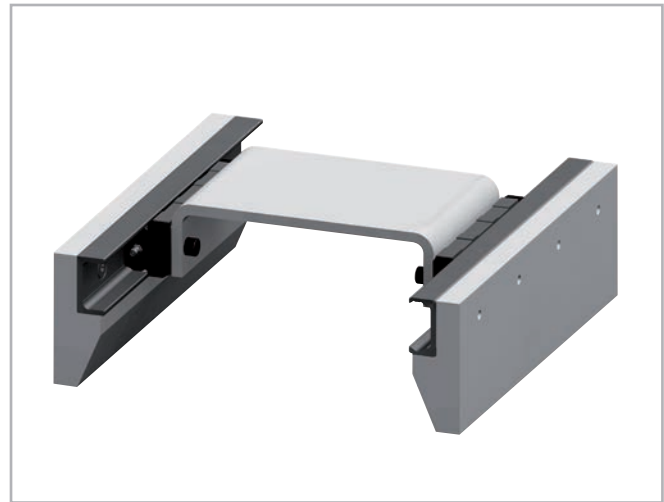

Fig. 61

K-rails and sliders are available in both sizes 43 and 63.

The custom NKE-slider may only be used in K-rails and cannot be exchanged with other Rollon sliders. The maximum allowable rotation angle of the NKE- and NUE-sliders are shown in the following table 28 and figure 62.  $\alpha_1$  is the maximum rotation angle counterclockwise,  $\alpha_2$  is clockwise.

Slider type	$\alpha_1$ [°]	$\alpha_2$ [°]
NKE43 and NUE43	2	2
NKE63 and NUE63	1	1

Tab. 28

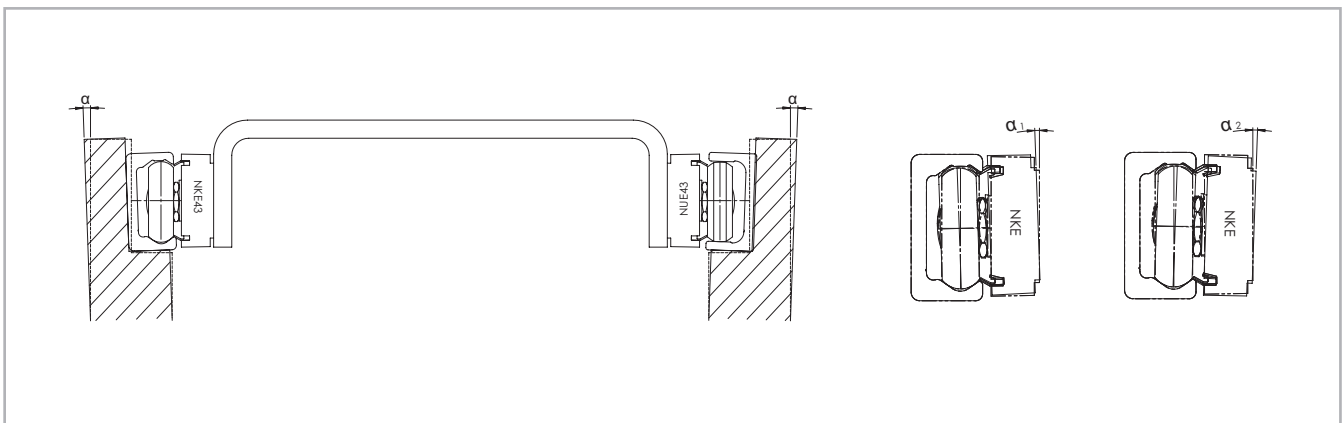

Fig. 62

**K+U-system maximum offset**

It must be noted that the slider in the U-rail will turn during the movement and rotation of the slider in the K-rail to allow an axial offset. During the combined effect of these movements, you must not exceed the maximum values (see tab. 29). If a maximum rotated NUE- slider is observed ( $2^\circ$  for size 43 and  $1^\circ$  for size 63), the maximum and minimum position of the slider in the U rail results from the values  $B_{0max}$  and  $B_{0min}$ , which are already considered by the additional rotation caused axial offset.  $B_{0nom}$  is a recommended nominal starting value for the position of a NUE-slider in the U-rail of a K+U-system.

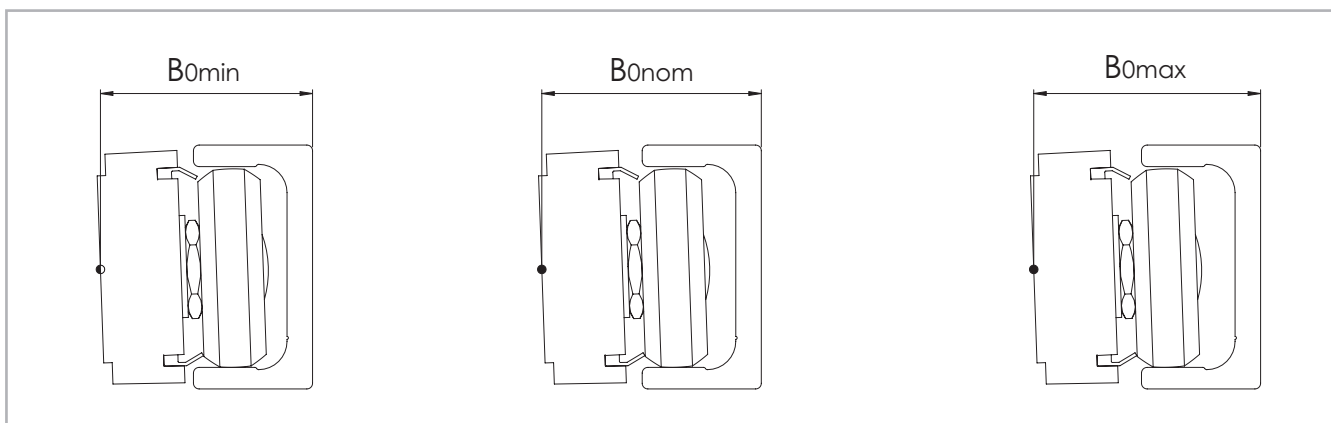

Fig. 63

Slider type	$B_{0min}$ [mm]	$B_{0nom}$ [mm]	$B_{0max}$ [mm]
NUE43 NUE43L	37.6	38.85	40.1
CS43	37.6	38.85	40.1
CD43	37.9	39.15	40.4
NUE63	50.95	52.70	54.45
CS63	49.85	51.80	53.75

Tab. 29

If a K-rail is used in combination with a U-rail, with guaranteed problem-free running and without extreme slider load, a pronounced height difference between the two rails can also be compensated for. The following illustration shows the maximum height offset  $b$  of the mounting surfaces in relation to the distance  $a$  of the rails (see fig. 64).

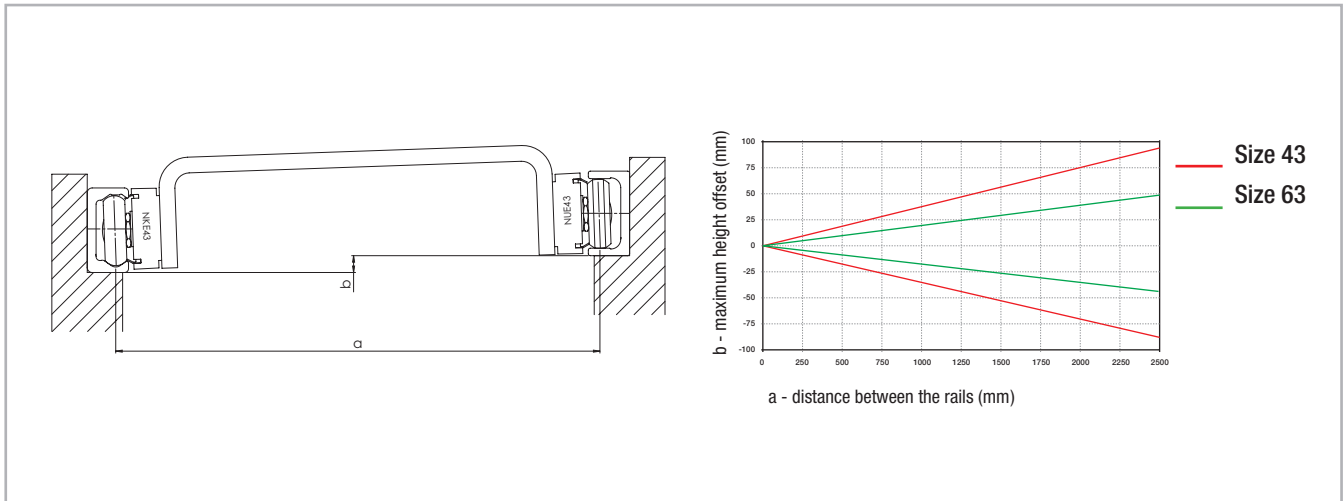

Fig. 64

Even the K+U-system can be used in different arrangements. If the same example as with the T+U-system is observed (see pg. CR-41, fig. 60), this solution, in addition to the prevention of vibrations and moments, also enables the compensation of larger deviations in parallelism in the vertical direction, without negative consequences to the guide. This is particularly important for longer strokes as it is more difficult to obtain a correct vertical parallelism.



Fig. 65

## > Preload

### Preload classes

The factory installed systems, consisting of rails and sliders, are available in two preload classes:

Standard preload K1 means a rail-slider combination with minimum preload which means the rollers are adjusted free of clearance for optimal running properties.

Usually preload K2 is used for rail-slider systems for increasing the rigidity (see pg. CR-35). When using a system with K2 preload a reduction of the loading capacities and service life must be taken into consideration (see tab. 30).

Preload class	Reduction y
K1	-
K2	0.1

Tab. 30

This coefficient y is used in the calculation formula for checking the static load and lifetime (see pg. CR-50, fig. 75 and pg. CR-54, fig. 92).

The interference is the difference between the contact lines of the rollers and the raceways of the rail.

Preload class	Interference* [mm]	Rail type
K1	0.01	all
K2	0.03	T, U...18
	0.04	T, U...28
	0.05	T, U...35
	0.06	T, U, K...43, T, U, K...63

\* Measured on the largest interior dimension between the raceways **Tab. 31**

**External preload**

The unique design of the Compact Rail product family enables applying a partial external preload on selected locations along the entire guide.

An external preload can be applied by pressure along the side surfaces of the guide rail according to the drawing below (see fig. 66). This local preload results in higher rigidity only at the locations where it is necessary (e.g. on reversing points with high dynamic auxiliary forces).

This partial preload increases the service life of the linear guide by avoiding a continually increased preload over the entire length of the guide. Also the required drive force of the linear carriage in the non-preloaded areas is reduced.

The amount of the externally applied preload is determined using two dial indicators by measuring the deformation of the rail sides. These are deformed by thrust blocks with pressure screws. The external preload must be applied when the slider is not directly located in the pressure zone.

Size	A [mm]
18	40
28	55
35	75
43	80
63	120

Tab. 32

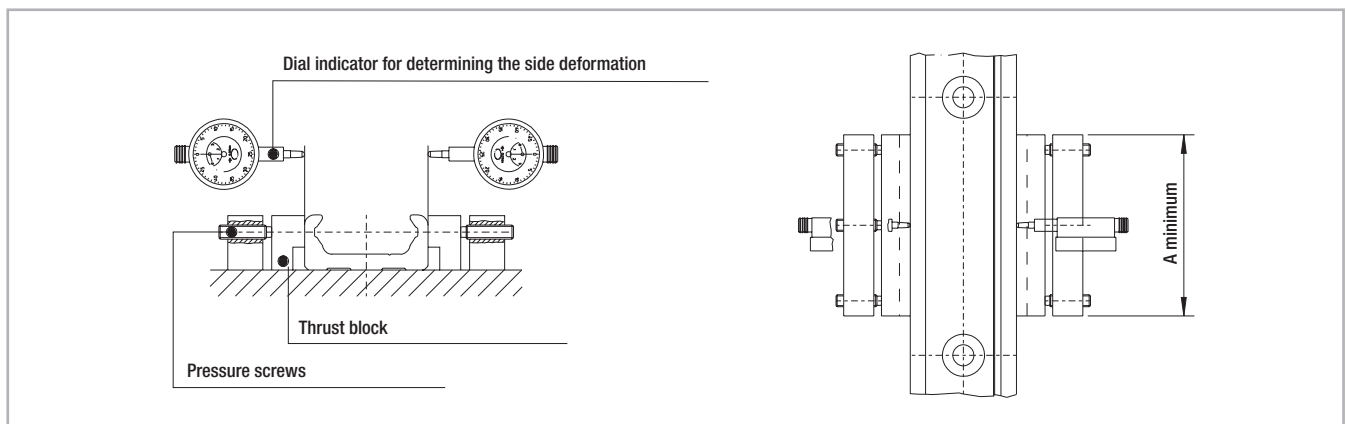

Fig. 66



The graph below indicates the value of the equivalent load as a function of the total deformation of both rail sides. The data relates to sliders with three rollers (see fig. 67).

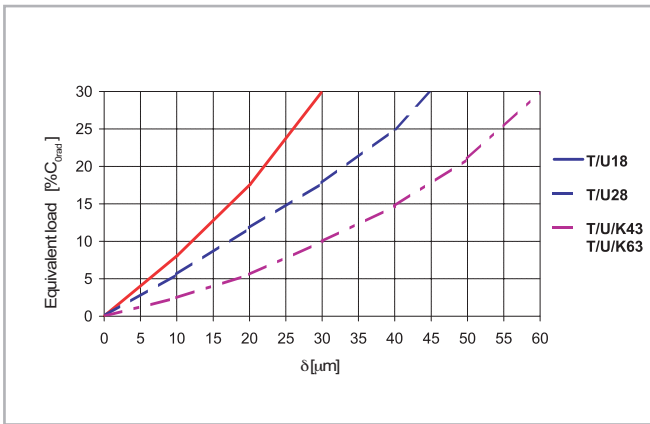

Fig. 67

> Drive force

**Frictional resistance**

The drive force required for moving the slider is determined by the combined resistance of the rollers, wipers and seals.

The ground raceways and rollers have a minimal coefficient of friction, which remains almost the same in both the static and dynamic state. The wiper and longitudinal seals are designed for an optimum protection of the system, without a significant negative influence on the quality of motion. The overall friction of the Compact Rail also depends on external factors such as lubrication, preload and additional forces. Table 33 below contains the coefficients of friction for each slider type (for CSW and CDW sliders no friction occurs to  $\mu_s$ ).

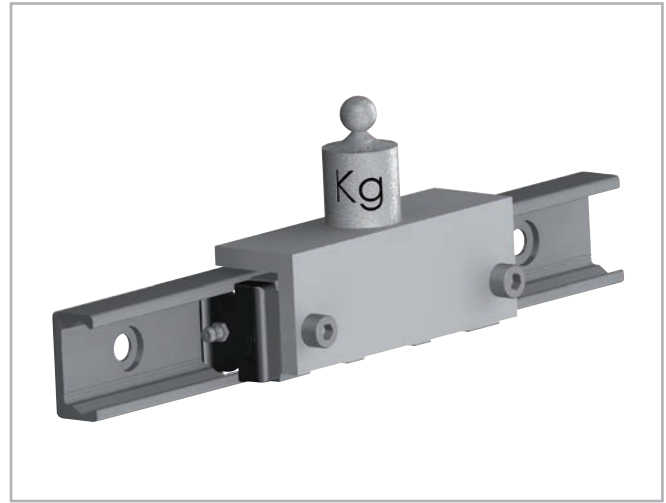

Fig. 68

Size	$\mu$ Roller friction	$\mu_w$ Wiper friction	$\mu_s$ Friction of longitudinal seals
18	0.003	$\frac{\ln(m \cdot 1000)^*}{0.98 \cdot m \cdot 1000}$	0.0015
28	0.003	$\frac{\ln(m \cdot 1000)^*}{0.06 \cdot m \cdot 1000}$	$\frac{\ln(m \cdot 1000)^*}{0.15 \cdot m \cdot 1000}$
35	0.005		
43	0.005		
63	0.006		

\* Kilograms must be used for load m

Tab. 33

The values given in Table 33 apply to external loads, which, with sliders with three rollers, are at least 10 % of the maximum load rating. For calculating the driving force for lower loads, please contact Rollon technical support.

**Calculation of drive force**

The minimum required drive force for the slider is determined with the coefficients of friction (see tab. 33) and the following formula (see fig. 69):

$F = (\mu + \mu_w + \mu_s) \cdot m \cdot g$	<p><math>m</math> = mass (kg)  <math>g</math> = 9.81 m/s<sup>2</sup></p>
---	--

Fig. 69

**Example calculation:**

If a NTE43 slider is used with a radial load of 100 kg, the result is  $\mu = 0.005$ ; from the formula the following is calculated:

$$\mu_s = \frac{\ln(100000)}{0.15 \cdot 100000} = 0.00076$$

$$\mu_w = \frac{\ln(100000)}{0.06 \cdot 100000} = 0.0019$$

Fig. 70

This is the minimum drive force for this example:

$$F = (0.005 + 0.0019 + 0.00076) \cdot 100 \cdot 9.81 = 7.51 \text{ N}$$

Fig. 71

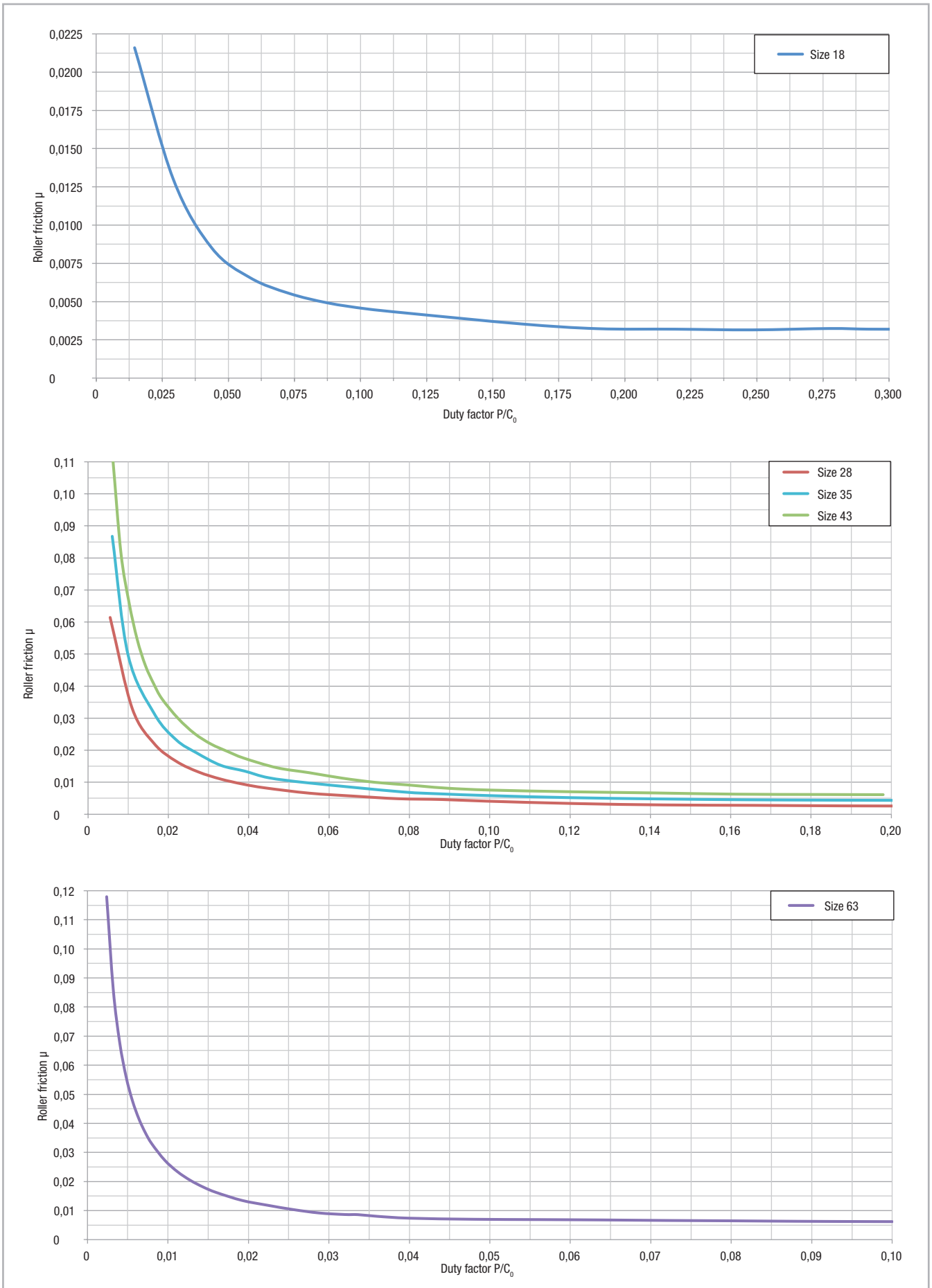

Fig. 72

## > Static load

The radial load capacity rating,  $C_{Orad}$ , the axial load capacity rating  $C_{Oax}$ , and moments  $M_x, M_y, M_z$  indicate the maximum permissible values of the load (see pg. CR-9ff), higher loads will have a detrimental effect on the running quality. A safety factor,  $S_0$ , is used to check the static load, which takes into account the basic parameters of the application and is defined more in detail in the following table:

### Safety factor $S_0$

No shock nor vibration, smooth and low-frequency reverse, high assembly accuracy, no elastic deformations	1 - 1.5
Normal installation conditions	1.5 - 2
Shock and vibration, high-frequency reverse, significant elastic deformation	2 - 3.5

Fig. 73

The ratio of the actual load to maximum permissible load may be as large as the reciprocal of the accepted safety factor,  $S_0$ , at the most.

$\frac{P_{Orad}}{C_{Orad}} \leq \frac{1}{S_0}$	$\frac{P_{Oax}}{C_{Oax}} \leq \frac{1}{S_0}$	$\frac{M_1}{M_x} \leq \frac{1}{S_0}$	$\frac{M_2}{M_y} \leq \frac{1}{S_0}$	$\frac{M_3}{M_z} \leq \frac{1}{S_0}$
--	--	--------------------------------------	--------------------------------------	--------------------------------------

Fig. 74

The above formulas are valid for a single load case.

If two or more forces are acting simultaneously, please check the following formula:

$\frac{P_{Orad}}{C_{Orad}} + \frac{P_{Oax}}{C_{Oax}} + \frac{M_1}{M_x} + \frac{M_2}{M_y} + \frac{M_3}{M_z} + y \leq \frac{1}{S_0}$	<ul style="list-style-type: none"> <li><math>P_{Orad}</math> = effective radial load (N)</li> <li><math>C_{Orad}</math> = permissible radial load (N)</li> <li><math>P_{Oax}</math> = effective axial load (N)</li> <li><math>C_{Oax}</math> = permissible axial load (N)</li> <li><math>M_1, M_2, M_3</math> = external moments (Nm)</li> <li><math>M_x, M_y, M_z</math> = maximum permissible moments in the different loading directions (Nm)</li> <li><math>y</math> = reduction due to preload</li> </ul>
--	--

Fig. 75

The safety factor  $S_0$  can lie on the lower given limit if the occurring forces can be determined with sufficient precision. If shock and vibration are present, the higher value should be selected. For dynamic applications higher safety is required. Please contact Rollon technical support.

> Calculation formulas

Examples of formulas for determining the forces on the most heavily loaded slider

For an explanation of the parameters in the formulas see pg. CR-53, fig. 90

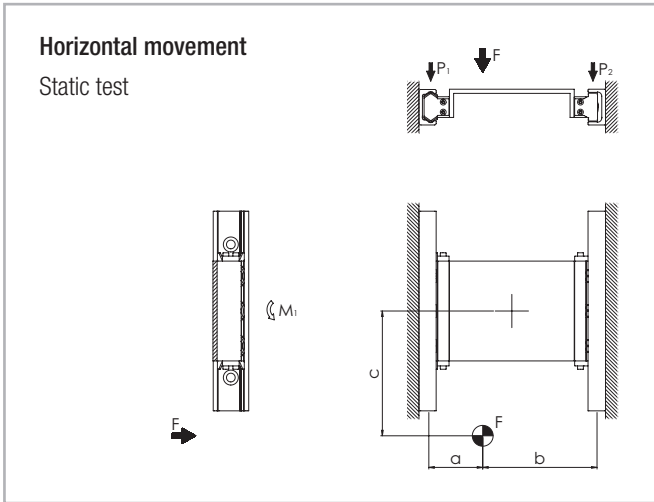

Fig. 76

Slider load:

$$P_1 = F \cdot \frac{b}{a+b}$$

$$P_2 = F - P_1$$

in addition each slider is loaded by a moment:

$$M_1 = \frac{F}{2} \cdot c$$

Fig. 77

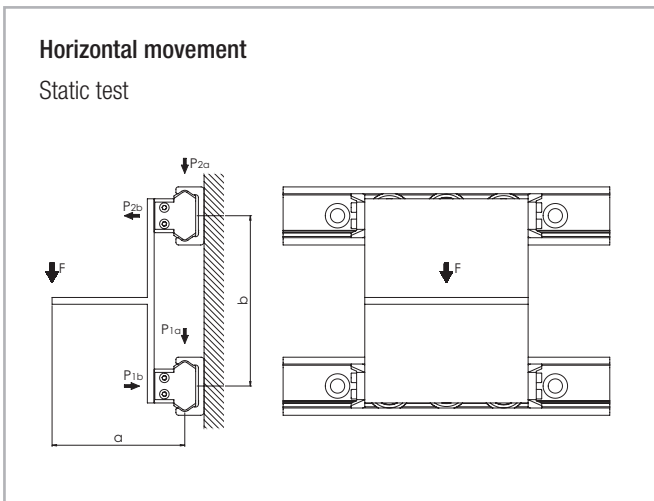

Fig. 78

Slider load:

$$P_{1a} \cong P_{2a} = \frac{F}{2}$$

$$P_{2b} \cong P_{1b} = F \cdot \frac{a}{b}$$

Fig. 79

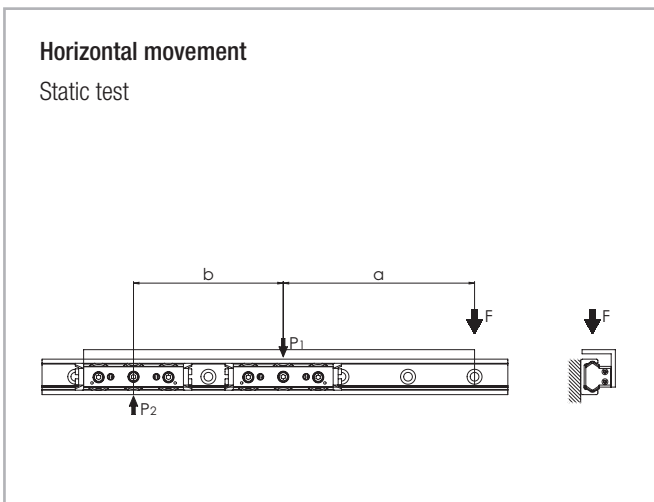

Fig. 80

Slider load:

$$P_2 = F \cdot \frac{a}{b}$$

$$P_1 = P_2 + F$$

Fig. 81

Note: Applies only if the distance between centers of the sliders  $b > 2x$  slider length

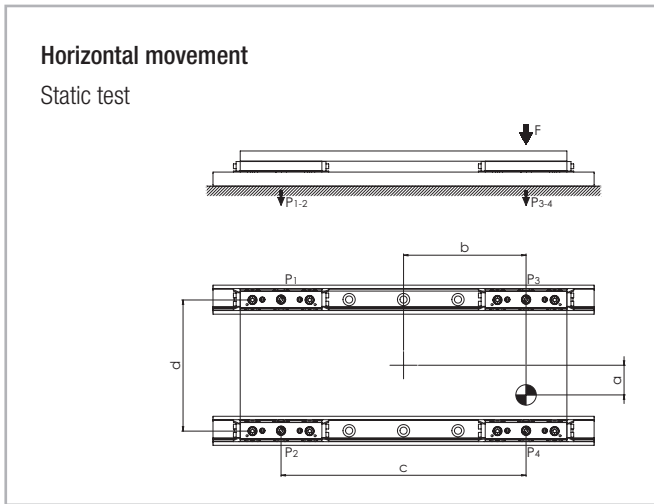

Fig. 82

Note: It is defined that slider no. 4 is always located closest to the point where the force is applied.

Slider load:

$$P_1 = \frac{F}{4} - \left( \frac{F}{2} \cdot \frac{b}{c} \right) - \left( \frac{F}{2} \cdot \frac{a}{d} \right)$$

$$P_2 = \frac{F}{4} - \left( \frac{F}{2} \cdot \frac{b}{c} \right) + \left( \frac{F}{2} \cdot \frac{a}{d} \right)$$

$$P_3 = \frac{F}{4} + \left( \frac{F}{2} \cdot \frac{b}{c} \right) - \left( \frac{F}{2} \cdot \frac{a}{d} \right)$$

$$P_4 = \frac{F}{4} + \left( \frac{F}{2} \cdot \frac{b}{c} \right) + \left( \frac{F}{2} \cdot \frac{a}{d} \right)$$

Fig. 83

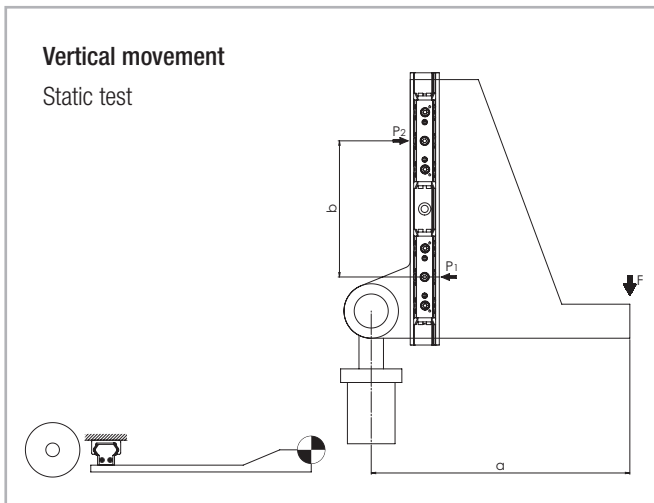

Fig. 84

Slider load:

$$P_1 \cong P_2 = F \cdot \frac{a}{b}$$

Fig. 85

Note: Applies only if the distance between centers of the sliders  $b > 2x$  slider length

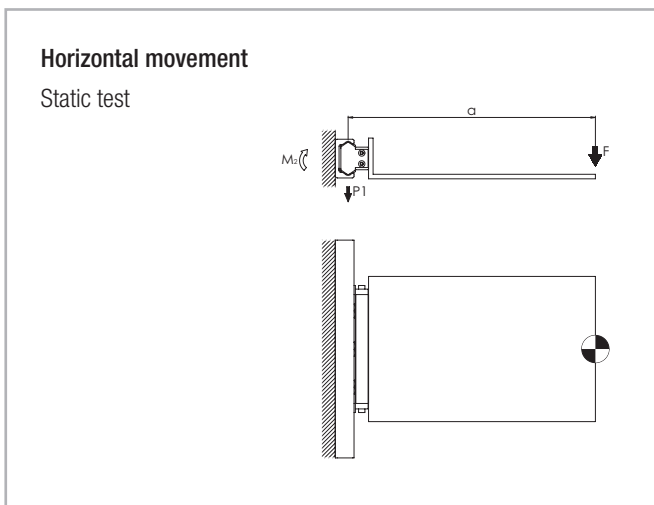

Fig. 86

Slider load:

$$P_1 = F$$

$$M_2 = F \cdot a$$

Fig. 87

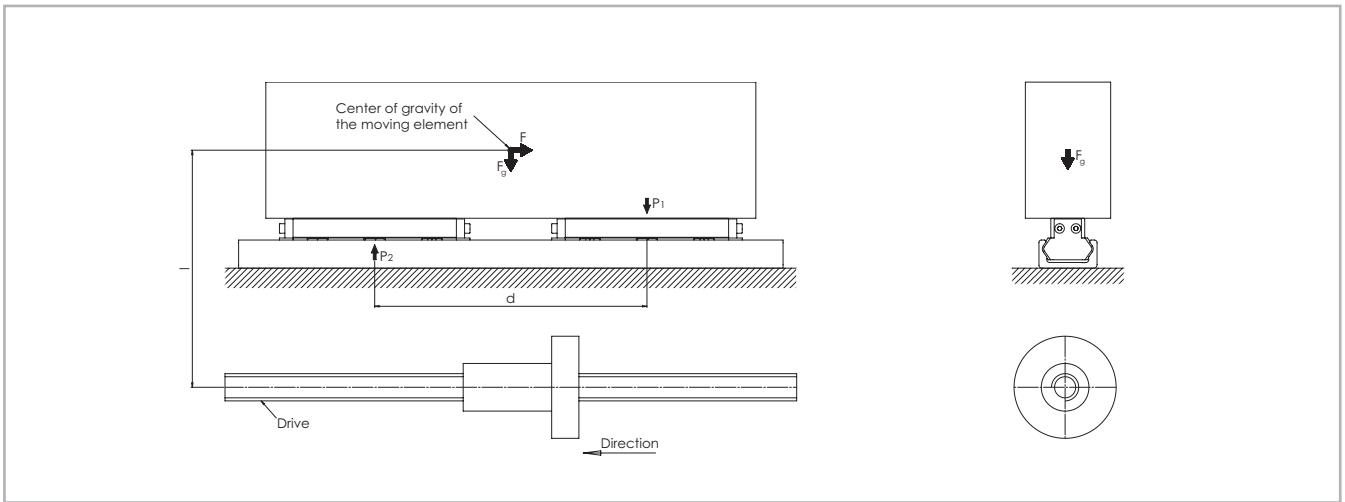

Fig. 88

**Horizontal movement**

Test with a moving element of the weight-force  $F_g$  at the instant the direction of movement changes

Inertial force	Slider load at time of reverse	
$F = m \cdot a$	$P_1 = \frac{F \cdot l}{d} + \frac{F_g}{2}$	$P_2 = \frac{F_g}{2} - \frac{F \cdot l}{d}$

Fig. 89

**Explanation of the calculation formula**

- F = effective force (N)
- $F_g$  = weight-force (N)
- $P_1, P_2, P_3, P_4$  = effective load on the slider (N)
- $M_1, M_2$  = effective moment (Nm)
- m = mass (kg)
- a = acceleration (m/s<sup>2</sup>)

Fig. 90

## > Service life calculation

The dynamic load capacity C is a conventional variable used for calculating the service life. This load corresponds to a nominal service life of 100 km. For values of the individual slider see pg. CR-9. Load capacities. The following formula (see fig. 91) links the calculated theoretical service life to the dynamic load capacity and the equivalent load:

$$L_{km} = 100 \cdot \left( \frac{C}{P} \cdot \frac{f_c}{f_i} \cdot f_h \right)^3$$

$L_{km}$  = theoretical service life (km)  
 $C$  = dynamic load capacity (N)  
 $P$  = effective equivalent load (N)  
 $f_c$  = contact factor  
 $f_i$  = application coefficient  
 $f_h$  = stroke factor

Fig. 91

The equivalent load P corresponds in its effects to the sum of the forces and moments working simultaneously on a slider. If these different load components are known, P results as follows:

$$P = P_r + \left( \frac{P_a}{C_{0ax}} + \frac{M_1}{M_x} + \frac{M_2}{M_y} + \frac{M_3}{M_z} + y \right) \cdot C_{0rad}$$

$y$  = reduction due to preload

Fig. 92

Here the external loads are assumed as constant in time. Brief loads, which do not exceed the maximum load capacities, do not have any relevant effect on the service life and can therefore be neglected.

The contact factor  $f_c$  refers to applications in which several sliders pass the same rail section. If two or more sliders move over the same point of a rail, the contact factor according to table 34 to be taken into account in the formula for calculation of the service life.

Number of sliders	1	2	3	4
$f_c$	1	0.8	0.7	0.63

Tab. 34



The application coefficient  $f_i$  takes into account the operational conditions in the service life calculation. It has a similar significance to the safety factor  $S_0$  in the static load test. It is calculated as described in the following table:

$f_i$	
Neither shocks nor vibrations, smooth and low-frequency direction change; clean operating conditions; low speeds (<1 m/s)	1 - 1.5
Slight vibrations, average speeds (1 - 2.5 m/s) and average frequency of direction change	1.5 - 2
Shocks and vibrations, high speeds (> 2.5 m/s) and high-frequency direction change; extreme dirt contamination	2 - 3.5

Tab. 35

The stroke factor  $f_h$  takes into account the higher load of the raceways and rollers during short strokes on the same total length of run. The corresponding values are taken from the following graph (for strokes longer than 1 m,  $f_h = 1$ ):

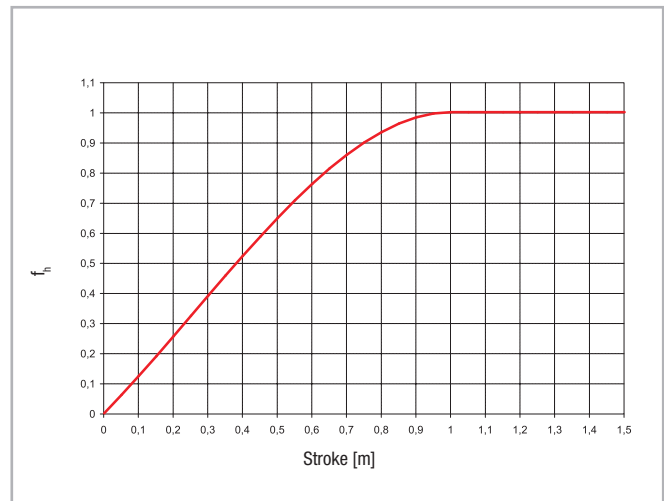

Fig. 93

## > Lubrication

### Roller pin lubrication

The bearings inside the Rollers are lubricated for life. To reach the calculated service life (see pg. CR-54), a film of lubricant should always be

present between the raceway and roller, this also serves to protect against corrosion of the ground raceways.

### Lubrication of the raceways

Proper lubrication during normal conditions:

- reduces friction
- reduces wear
- reduces the load of the contact surfaces through elastic deformations
- reduces running noise

## > N-slider lubrication

### Lubrication when using N-sliders

NTE-, NUE- and NKE-sliders (except for types NT/NU18) are equipped with a self-lubrication kit for periodic lubrication of the slider.

This provides a progressive release of lubricant (see tab. 36) on the race-

way during operation of the slider. The expected service life is up to 2 million cycles, depending on the type of application. The zerk fittings (see fig. 94) provide the lubrication.

Lubricant	Thickening agent	Temperature range [°C]	Dynamic viscosity [mPa·s]
Mineral oil	Lithium soap	-30... to +120	< 1000

Tab. 36

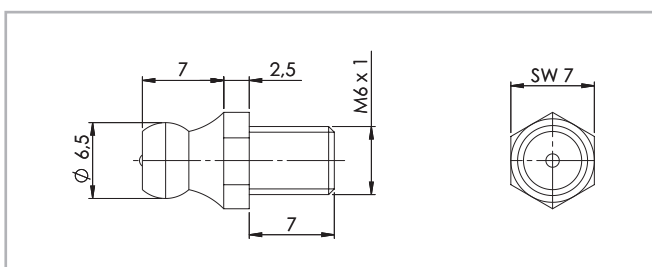

Fig. 94

### Replacement of N-slider wiper head

Sliders NTE, NUE and NKE are equipped with a safety system made of longitudinal sealing lips and rigid, spring-preloaded, and therefore self-adjusting, wipers on both sides of the head for automatic cleaning of the raceways. The slider heads can be removed for replacement. To do this it is necessary to loosen the zerk fittings (except for types NT/NU18), which should be refastened after installing the new heads with the following tightening torque:

Slider type	Tightening torque [Nm]
NTE, NUE28	0.4 - 0.5
NTE, NUE, NKE43 and 63	0.6 - 0.7

Tab. 37

## > C-slider lubrication

### Lubrication when using C-sliders

The C series sliders can be provided with wipers made of polyamide to remove contaminants on the raceways. Since the sliders do not have a self-lubrication kit, manual lubrication of the raceways is required. A guideline is to lubricate the raceways every 100 km or every 6 months.

We recommend a roller bearing lubricant with a lithium base of average consistency (see tab. 38).

Lubricant	Thickening agent	Temperature range [°C]	Dynamic viscosity [mPas]
Roller bearing lubricant	Lithium soap	-30 to +170	4500

Tab. 38

Different lubricants are available on request for special applications:

- FDA-approved lubricant for use in the food industry
- specific lubricant for clean rooms
- specific lubricant for the marine technology sector
- specific lubricant for high and low temperatures

For specific information, contact Rollon technical support.

## > Corrosion protection

The Compact Rail product family has a standard corrosion protection system by means of electrolytic-zinc plating according to ISO 2081. If increased corrosion protection is required, application-specific surface

treatments are available upon request, e.g. FDA-approved nickel plated for use in the food industry. For more information contact Rollon technical support.

## > Speed and acceleration

The Compact Rail product family is suitable for high operating speeds and accelerations.

Size	Speed [m/s]	Acceleration [m/s <sup>2</sup> ]
18	3	10
28	5	15
35	6	15
43	7	15
63	9	20

Tab. 39

## > Operating temperatures

The temperature range for continuous operation is: -30 °C / +120 °C with occasional peaks up to +150 °C.

Peaks up to +170 °C can also be reached with the use of C-series sliders (except size 63) not equipped with polyamide wipers.

# Installation instructions

## > Fixing holes

### V-holes with 90° bevels

The selection of rails with 90° countersunk holes is based on the precise alignment of the threaded holes for installation. Here the complex alignment of the rail to an external reference is omitted, since the rail aligns during installation by the self-centering of the countersunk screws on the existing hole pattern.

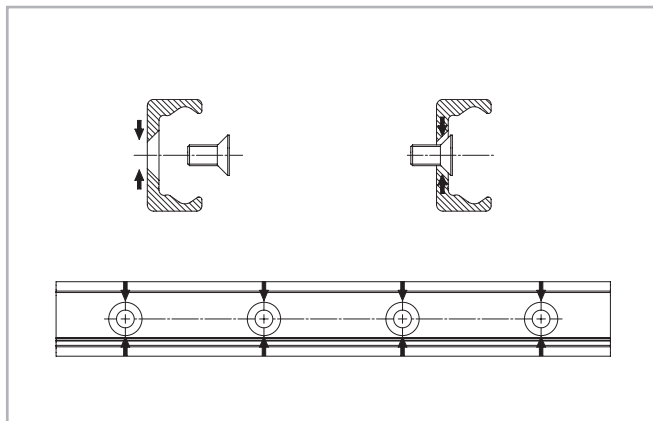

Fig. 95

### C-holes with cylindrical counterbore

The cylindrical screw has, as shown, some play in the countersunk fixing hole, so that an optimum alignment of the rail can be achieved during installation (see fig. 96).

The area T is the diameter of the possible offset, in which the screw center point can move during the precise alignment.

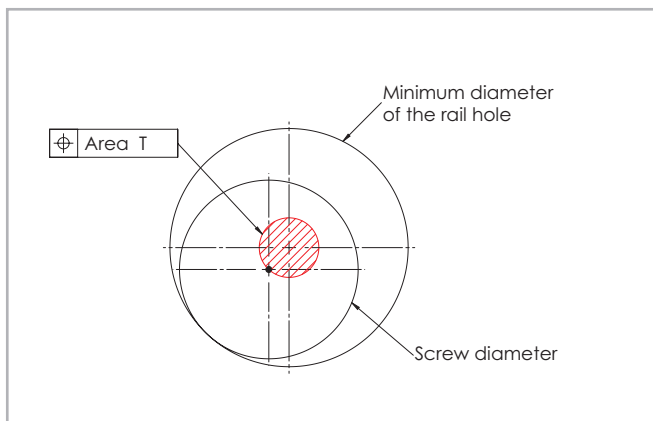

Fig. 96

Rail type	Area T [mm]
TLC18 - ULC18	∅ 1.0
TLC28 - ULC28	∅ 1.0
TLC35 - ULC35	∅ 1.5
TLC43 - ULC43 - KLC43	∅ 2.0
TLC63 - ULC63 - KLC63	∅ 1.0

Tab. 40

The minimum chamfers on the fixing threads are listed on the table below.

Size	Chamfer [mm]
18	0.5 x 45°
28	0.6 x 45°
35	0.5 x 45°
43	1 x 45°
63	0.5 x 45°

Tab. 41

### Example for fixing with Torx® screws (custom design)

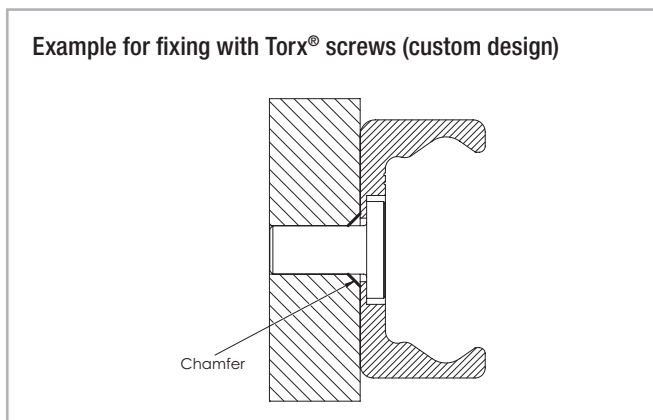

Fig. 97

## > Adjusting the sliders

Normally the linear guides are delivered as a system consisting of rail and adjusted sliders. If rail and slider are delivered separately or if the slider is installed in another raceway, the preload must be set again.

Setting the preload:

- (1) Check the cleanliness of the tracks.
- (2) Insert the slider in the rail (CSW and CDW sliders should be inserted without wipers). Slightly loosen the fixing screws of the roller pins (no marking) to be adjusted.
- (3) Position the slider on one end of the rail.
- (4) For the U rails there must be a thin support (e.g. set key) under the ends of the slider body to ensure the horizontal alignment of the slider in the flat raceways.
- (5) Insert the included special flat wrench from the side between the rail and the slider and slip it onto the hexagon of the eccentric roller to be adjusted.
- (6) By turning the flat key clockwise, the roller to be adjusted is pressed

against the upper track and the slider is then without play. Avoid a preload that is too high. It generates increased wear and reduces the service life.

(7) While holding the correct position of the roller with the adjustment key, the fixing screw can be carefully tightened. The exact tightening torque will be checked later (see fig. 98 and tab. 42).

(8) Move the slider in the rail and check the preload over the entire length of the rail. It should move easily and the slider should not have play at any location of the rail.

(9) For sliders with more than 3 rollers, repeat this process with each eccentric roller. Always start with each roller to be adjusted. Make sure that all rollers have even contact to the tracks.

(10) Now tighten the fixing screws with the specified tightening torque from the table while the flat key holds the angle adjustment of the pin. A special thread in the roller pin secures the set position.

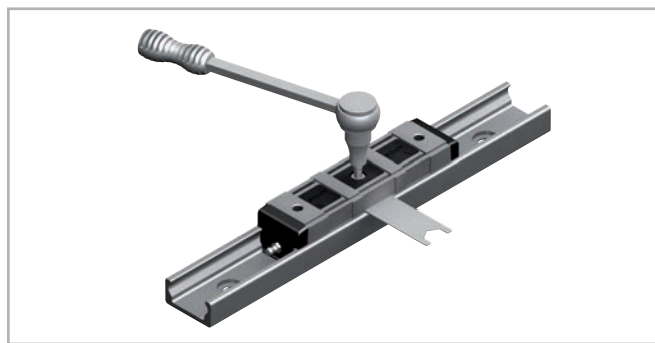

Fig. 98

Slider size	Tightening torque [Nm]
18	3
28	7
35	12
43	12
63	35

Tab. 42

## > Use of radial ball bearing rollers

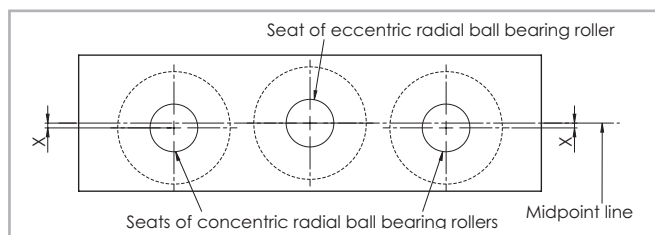

Fig. 99

Slider size	X [mm]
18	0.40
28	0.45
35	0.60
43	0.60
63	0.55

Tab. 43

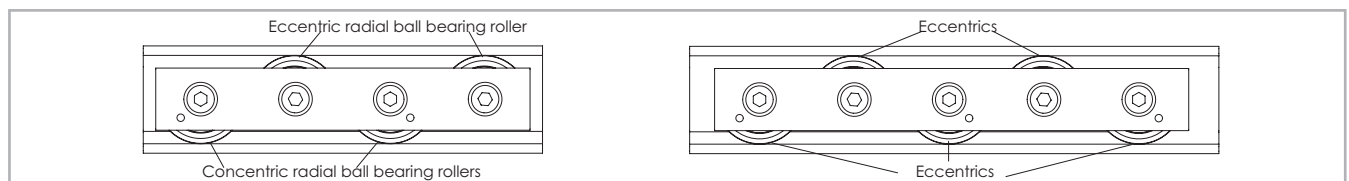

Fig. 100

If purchasing "Radial ball bearing rollers" to install on your own structure (see p. CR-29) we advise:

- Using a maximum of 2 concentric radial ball bearing rollers

- Offset the seats of the concentric radial ball bearing rollers with respect to those of the eccentric radial ball bearing rollers according to the table (tab. 43).

## > Installing the single rail

The T- and K-rails can be installed in two positions relative to the external force. For axial loading of the slider (fig. 101, pos. 2), the load capacity is reduced because of the decline in contact area caused by the change in position. Therefore, the rails should be installed in such a way that the load on the rollers acts in the radial direction (fig. 101, pos. 1). The number of fixing holes in the rail in combination with screws of property class 10.9 is dimensioned in accordance with the load capacity values. For critical applications with vibrations or higher demand for rigidity, a support of the rail (fig. 101, pos. 3) is advantageous.

This reduces deformation of the sides and the load on the screws. The installation of a rail with countersunk holes requires an external reference for alignment. This reference can also be used simultaneously as rail support if required. All information in this section on alignment of the rails, refers to rails with counterbored holes. Rails with countersunk holes self-align using the specified fixing hole pattern (see pg. CR-58, fig. 95).

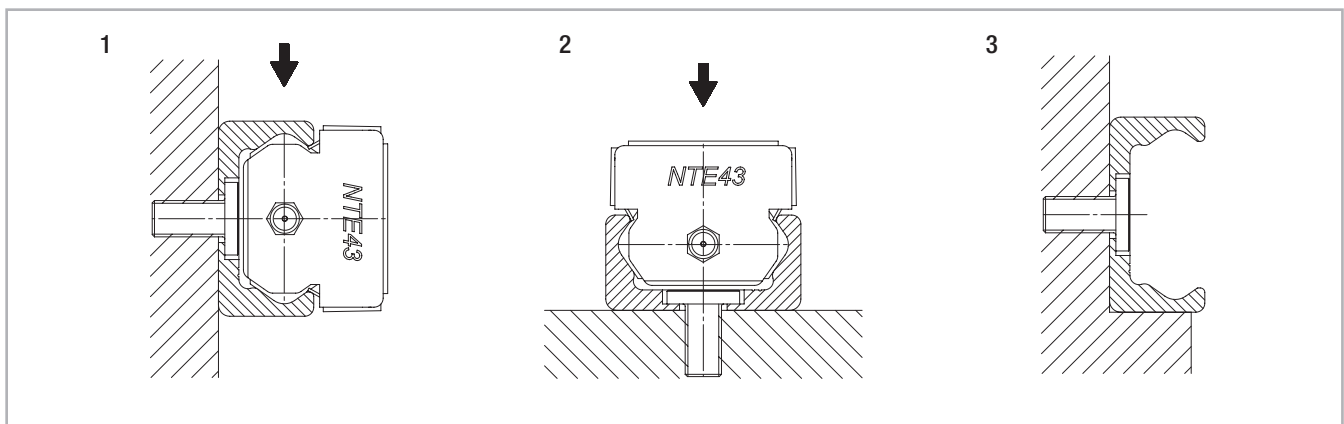

Fig. 101

**Rail installation with reference surface as support**

- (1) Remove unevenness, burrs and dirt from the support surface.
- (2) Press the rail against the support surface and insert all screws without tightening them.
- (3) Start tightening the fixing screws to the specified torque on one end of the rail while continuing to hold pressure on the rail against the support surface.

Screw type	Tightening torque [Nm]
M4 (T..., U... 18)	3
M5 (T..., U... 28)	9
M6 (T..., U... 35)	12
M8 (T..., U..., K... 43)	22
M8 (T..., U..., K... 63)	35

Tab. 44

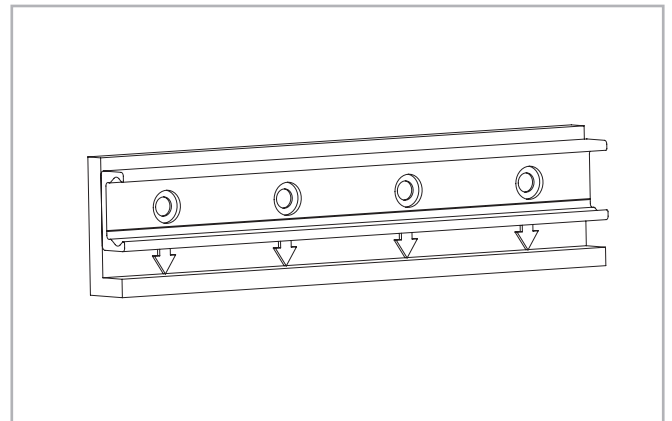

Fig. 102

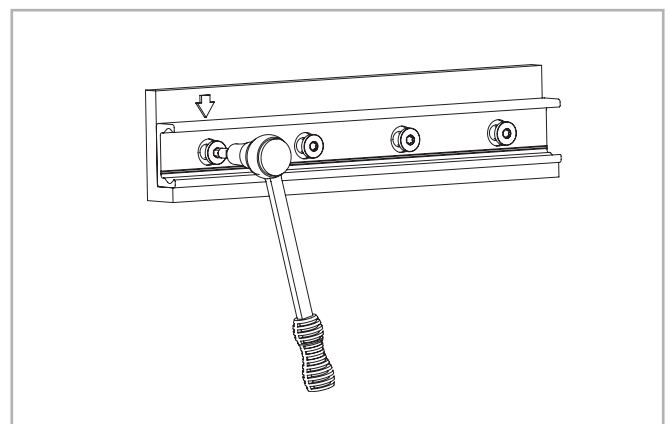

Fig. 103

### Rail installation without support

(1) Carefully lay the guide rail with installed slider on the mounting surface and slightly tighten the fixing screws so that the guide rail lightly touches the mounting surface.

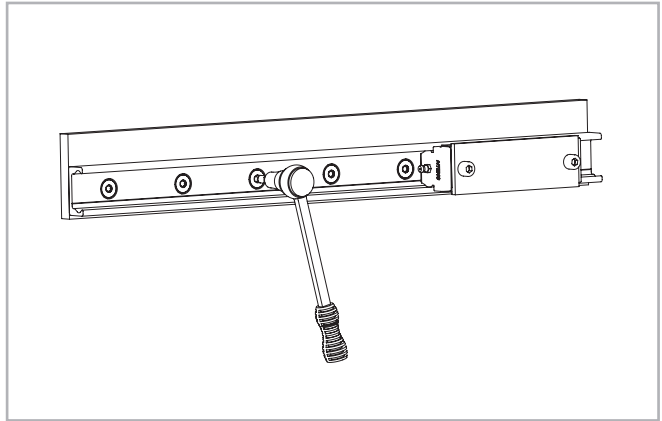

Fig. 104

(2) Install a dial indicator so that the offset of the rail to a reference line can be measured. Now position the slider in the center of the rail and set the dial indicator to zero. Move the slider back and forth between each two hole spacings and carefully align the rail. Fasten the three center screws of this area now with the the specified tightening torque, see pg. fig. 105.  
(3) Now position the slider on one end of the rail and carefully align the rail to zero on the dial indicator.

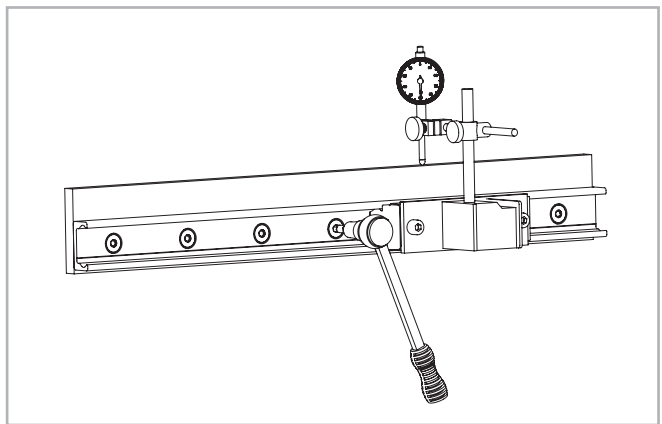

Fig. 105

(4) Begin to tighten the screws as specified while moving the slider together with the dial indicator. Make sure that it does not show any significant deflection. Repeat this procedure from the other end of the rail.

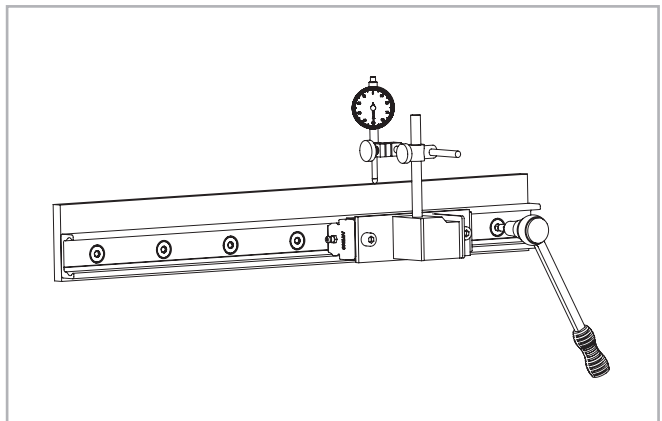

Fig. 106



### > Parallel installation of two rails

If two T-rails or a T+U-system are installed, the height difference of the two rails must not exceed a certain value (obtainable from the table below) in order to ensure proper guiding. These maximum values result from the maximum allowable twisting angle of the rollers in the raceways (see tab. 45). These values account for a load capacity reduction of 30% on the T-rail and must absolutely be maintained in every case.

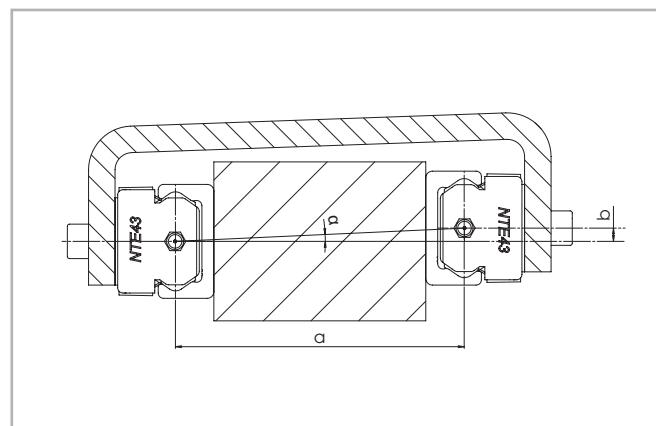

Fig. 107

Size	$\alpha$
18	1 mrad (0.057°)
28	2.5 mrad (0.143°)
35	2.6 mrad (0.149°)
43	3 mrad (0.171°)
63	5 mrad (0.286°)

Tab. 45

Example:

NTE43: if  $a = 500 \text{ mm}$ ;  $b = a \cdot \tan \alpha = 1.5 \text{ mm}$

When using two T-rails, the maximum parallelism deviation must not be exceeded (see tab. 46). Otherwise stresses can occur, which can result in a reduction in load capacity and service life.

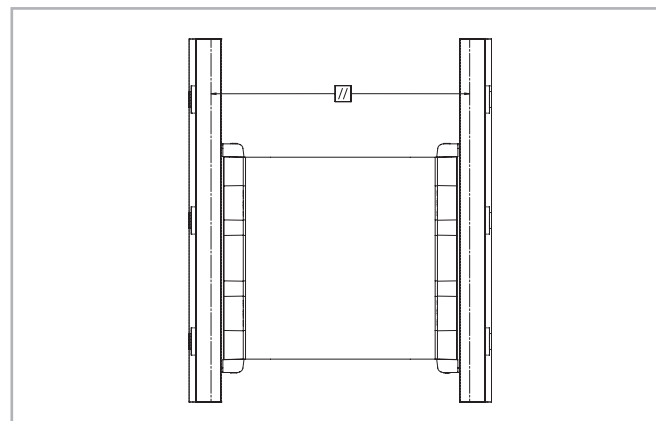

Fig. 108

Rail size	K1	K2
18	0.03	0.02
28	0.04	0.03
35	0.04	0.03
43	0.05	0.04
63	0.06	0.05

Tab. 46

Note: For parallelism problems, it is recommended to use a T+U or K+U system, since these combinations compensate for inaccuracies (see pg. CR-40, or CR-42).

C  
R

### Parallel installation of two T-rails

(1) Clean chips and dirt from the prepared mounting surfaces and fasten the first rail as described in the section on installation of a single rail.

(2) Fasten the second rail on the ends and the center. Tighten the screws in Position A and measure the distance between the raceways of the two rails.

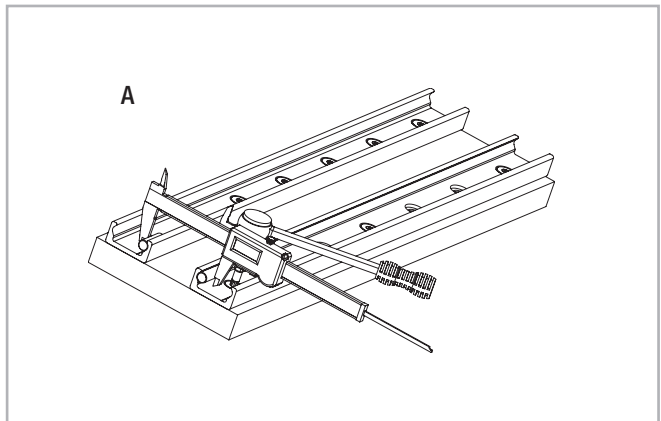

Fig. 109

(3) Fasten the rail in Position B so that the distance between the raceways does not exceed the measured values in Position A while maintaining the tolerances (see pg. CR-63, tab. 46) for parallel rail installation.

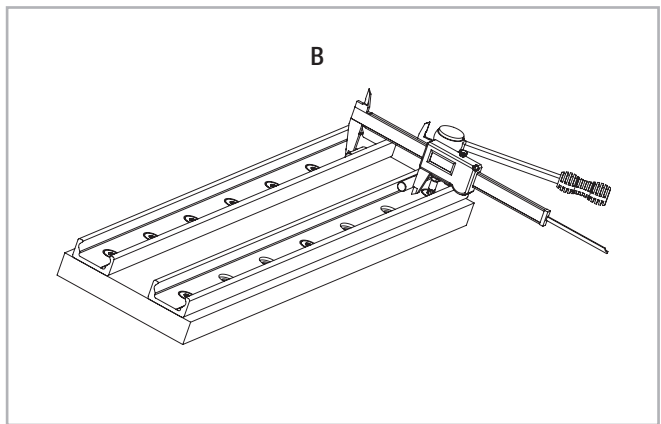

Fig. 110

(4) Fasten the screw in Position C so that the distance of the raceways is as close to an average between the two values from A and B as possible.

(5) Fasten all other screws and check the specified tightening torque of all fixing screws (see pg. CR-61, tab. 44).

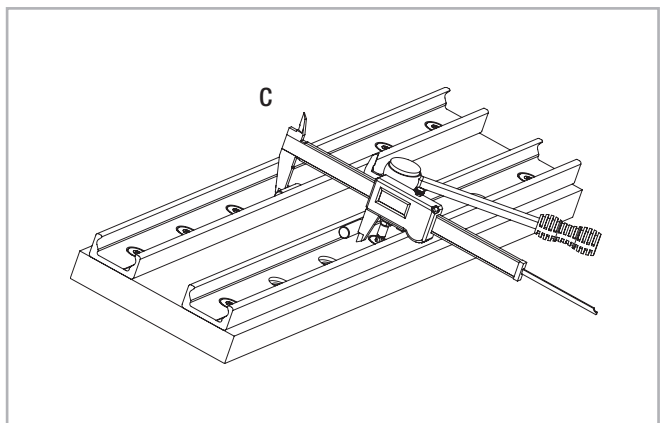

Fig. 111

## > Installation of the T+U- or the K+U-system

When using a two-track parallel linear guide we recommend the use of a fixed bearing / compensating bearing system: The combination of T+U-rails for compensation of deviations in parallelism or the K+U-system to compensate for deviations in parallelism in two planes.

### Installation steps

(1) For a fixed bearing / compensating bearing system the fixed bearing rail is always installed first. This is then used as a reference for the compensating bearing rail.

Then proceed as described in the section on installation of a single rail (see pg. CR-60).

(2) Install the compensating bearing rail and only tighten the fixing screws slightly.

(3) Insert the sliders in the rails and install the element to be moved, without tightening its screws.

(4) Insert the element in the center of the rails and tighten it with the correct tightening torque (see pg. CR-59, tab. 42).

(5) Tighten the center rail fixing screws to the specified torque (see fig. 113).

(6) Move the element to one end of the rail and start tightening the rest of the screws in the direction away from the slider.

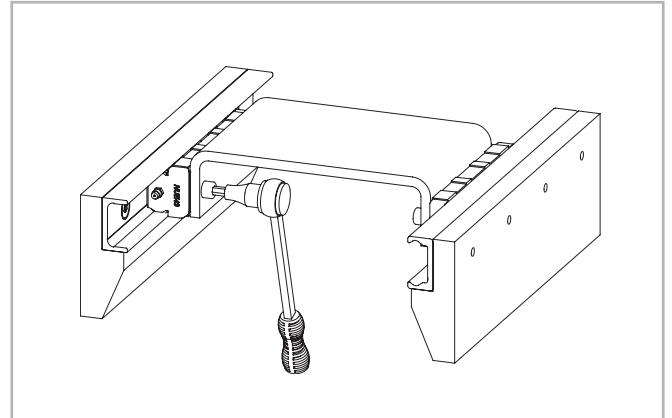

Fig. 112

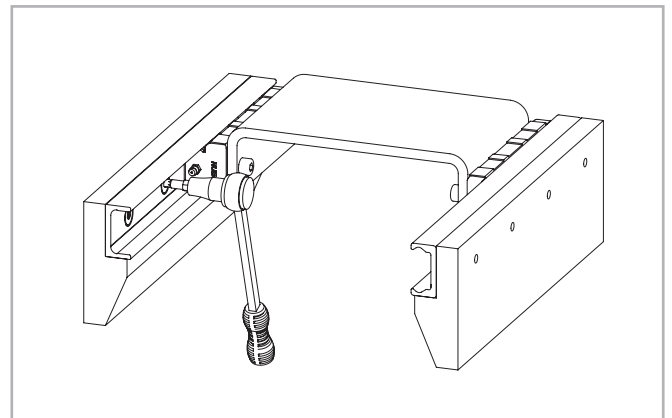

Fig. 113

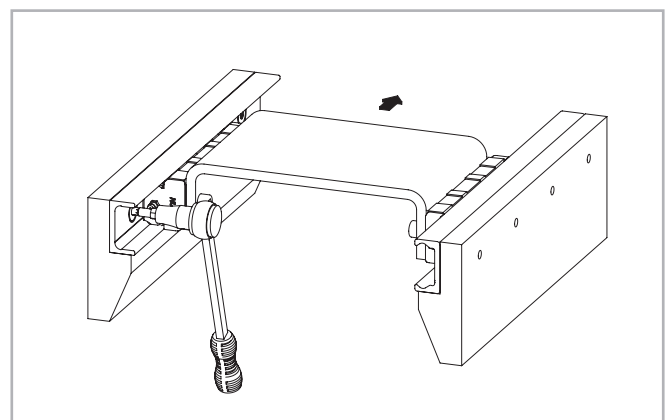

Fig. 114

## > Joined Rails

If long guide rails are required, two or more rails can be joined to the desired length. When putting guide rails together, be sure that the register marks shown in fig. 115 are positioned correctly.

These are fabricated asymmetric for parallel application of joined guide rails, unless otherwise specified.

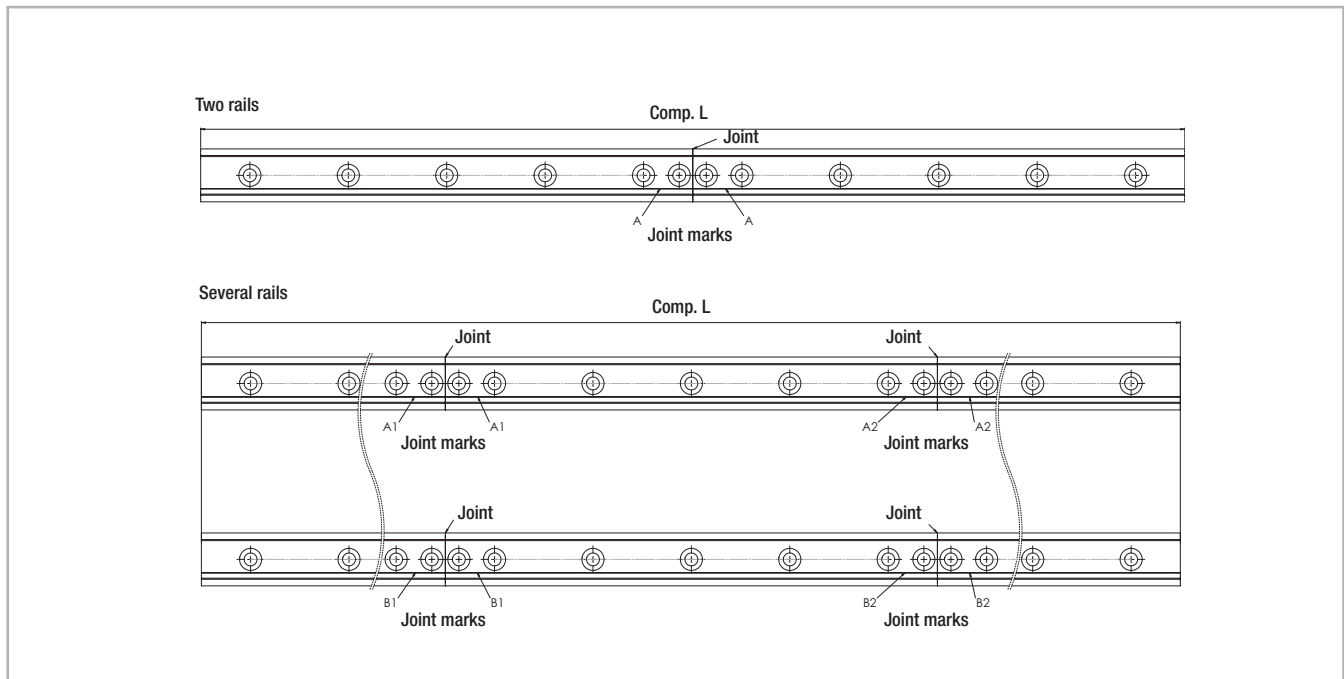

Fig. 115

**General information**

The maximum available rail length in one piece is indicated in table 7 on page CR-16. Longer lengths are achieved by joining two or more rails (joined rails).

Rollon then machines the rail ends at a right angle to the impact surfaces and marks them. Additional fixing screws are included with the delivery, which ensure a problem-free transition of the slider over the joints, if the following installation procedures are followed. Two additional threaded holes (see fig. 116) are required in the load-bearing structure. The included end fixing screws correspond to the installation screws for the rails for cylindrical counterbores (see pg. CR-58).

The alignment fixture for aligning the rail joint can be ordered using the designation given in the table (see pg. CR-30, tab. 19 and 20).

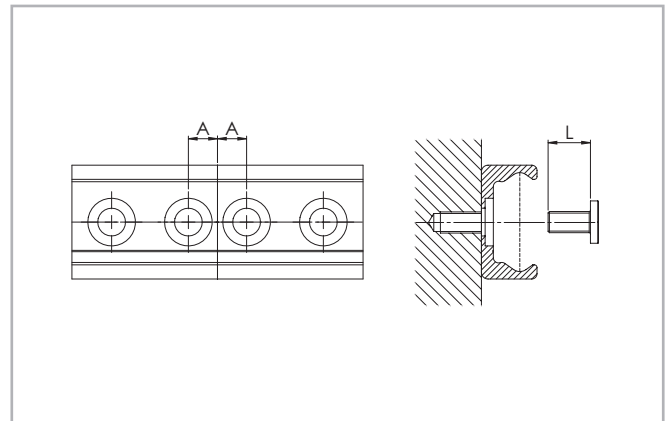

Fig. 116

Rail type	A [mm]	Threaded hole (load-bearing structure)	Screw type	L [mm]	Alignment fixture
T..., U...18	7	M4	see pg. CR-31	8	AT18
T..., U...28	8	M5		10	AT28
T..., U...35	10	M6		13	AT35
T..., U...43	11	M8		16	AT43
T..., U...63	8	M8		20	AT63
K...43	11	M8		16	AK43
K...63	8	M8		20	AK63

Tab. 47

## > Installation of joined rails

After the fixing holes for the rails are made in the load-bearing structure, the joined rails can be installed according to the following procedure:

- (1) Fix the individual rails on the mounting surface by tightening all screws except for each last one on the rail joint.
- (2) Install the end fixing screws without tightening them (see fig. 117).

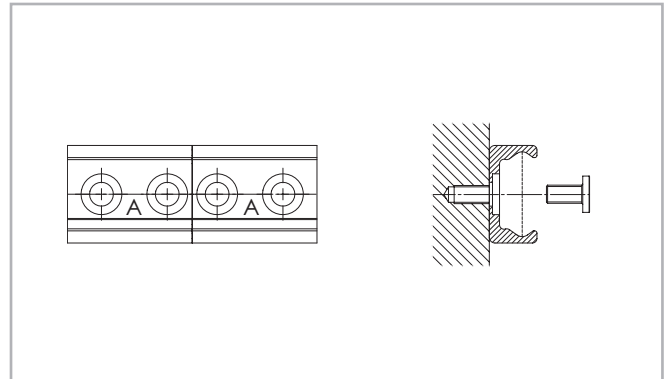

Fig. 117

- (3) Place the alignment fixture on the rail joint and tighten both set screws uniformly, until the raceways are aligned (see fig. 118).
- (4) After the previous step (3) it must be checked if both rail backs lie evenly on the mounting surface. If a gap has formed there, this must be shimmed.

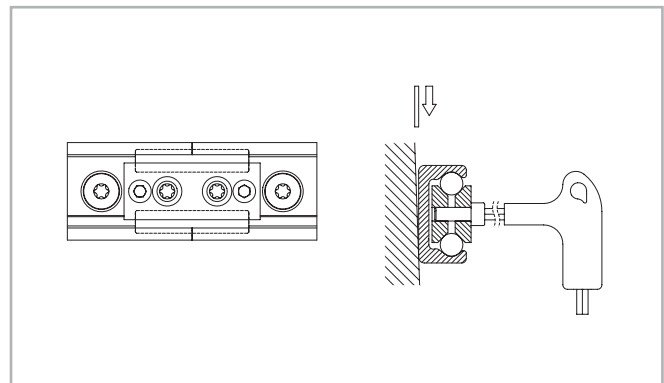

Fig. 118

- (5) The bottom of the rails should be supported in the area of the transition. Here a possible existing gap must be looked for, which must be closed if necessary for correct support of the rail ends by shims.

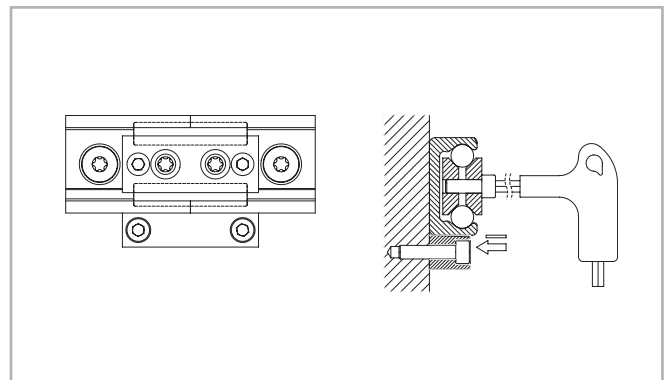

Fig. 119

- (6) Insert the key through the holes in the alignment fixture and tighten the screws on the rail ends.
- (7) For rails with 90° countersunk holes, tighten the remaining screws starting from the rail joint in the direction of the rail center. For rails with cylindrical counter-sunk holes, first adjust the rail to an external reference, then proceed as described above.
- (8) Remove the alignment fixture from the rail.

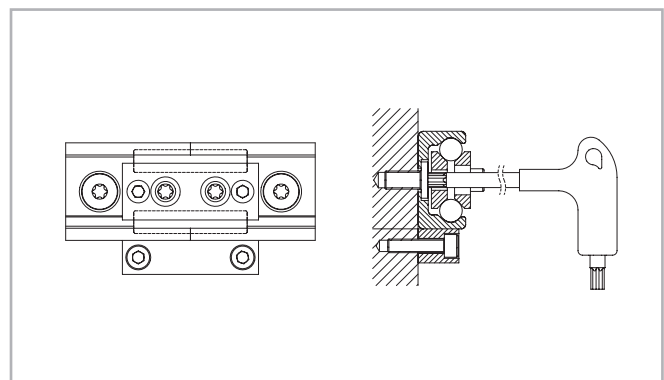

Fig. 120

# Ordering key

## > Rail / slider system

TLC	4560	/2/	CD	W	28	-125	-2Z	-B	-NIC
									Expanded surface protection if deviation from Standard ISO 2081 <i>see pg. CR-57</i>
									Configuration depending on type of slider <i>see pgs. CR-20 and CR-23</i>
								Roller seal	<i>see pg. CR-29</i>
								Slider length Dimension A	<i>see pg. CR-16, tab. 8-11</i>
								Size	<i>see pg. CR-16</i>
								Wiper optional	<i>see pg. CR-30, fig. 43</i>
								Slider type	<i>see pg. CR-16</i>
								Number of sliders in one rail	
								Rail length in mm	<i>see pg. CR-15, tab. 7</i>
								Rail type	<i>see pg. CR-12</i>

Ordering example: TLC-04560/2/CDW28-125-2Z-B-NIC

Rail composition: 1x3280+1x1280 (only for joint processed rails)

Hole pattern: 40-40x80-40//40-15x80-40 (please always specify the hole pattern separately)

Notes on ordering: The rail length codes are always 5 digits, the slider length codes are always 3 digits; use zeroes as a prefix when lengths are shorter

## > Rail

TLV	-43	-5680	-NIC
			Expanded surface protection if deviation from Standard ISO 2081 <i>see pg. CR-57</i>
			Rail length in mm <i>see pg. CR-15, table 7</i>
			Size <i>see pg. CR-12</i>
			Rail type <i>see pg. CR-12</i>

Ordering example: TLV-43-05680-NIC

Rail composition: 1x880+2x2400 (only for joint processed rails)

Hole pattern: 40-10x80-40//40-29x80-40//40-29x80-40 (please always specify the hole pattern separately)

Notes on ordering: The rail length codes are always 5 digits; use zeroes as a prefix when lengths are shorter

> **Slider**

<b>CS</b>	<b>28</b>	<b>-100</b>	<b>-2RS</b>	<b>-B</b>	<b>-NIC</b>	
						Expanded surface protection if deviation from Standard ISO 2081 <i>see pg. CR-57</i>
						Configuration <i>depending on type of slider</i> <i>see pgs. CR-20 and CR-23</i>
			Roller seal			<i>see pg. CR-29</i>
			Slider length Dimension A			<i>see pg. CR-16, table 8-11</i>
	Size					<i>see pg. CR-16</i>
Slider type						<i>see pg. CR-16</i>

Ordering example: CS28-100-2RS-B-NIC

Notes on ordering: The slider length codes are always 3 digits; use zeroes as a prefix when lengths are shorter

> **Wipers**

<b>WT</b>	<b>28</b>	
	Size	<i>see pg. CR-16</i>
Wiper type		<i>see pg. CR-30, fig. 43</i>

Ordering example: WT28



Notes 

Large grid area for notes.

C  
R



**ROLLON**<sup>®</sup>  
Linear Evolution

X-Rail



## Product explanation



### > X-Rail: Corrosion resistant or zinc-plated steel linear bearings



Fig. 1

X-Rail is the product family of roller embossed guide rails for applications in which an economical price to performance ratio and high corrosion resistance are required.

X-Rail includes two sets of products: a rail with shaped raceways (0 degrees of axial play) and a rail with flat raceways (1 degree of axial play).

All products are available in stainless steel or zinc-plated steel. There are three different sizes of guide rails, and the sliders for the guide rails are available in different versions.

#### The most important characteristics:

- Corrosion resistant, FDA/USDA compliant materials
- Compensates for deviations in mounting structure parallelism
- Not sensitive to dirt due to internal tracks
- Wide temperature range of application
- Easy adjustment of sliders on the guide rails

#### Preferred areas of application of the X-Rail product family:

- Construction and machine technology (e.g., safety doors, washing bay accessories)
- Medical technology (e.g., hospital accessories, medical equipment)
- Transport (e.g., rail transport, naval, automotive industry)
- Food and beverage industry (e.g., packaging, food processing)
- Building technology
- Energy technology (e.g., industrial furnaces, boilers)

### Fixed bearings (T-rails)

Fixed bearing rails are used for the main load bearing in radial and axial forces.



Fig. 2

### Compensating bearings (U-rails)

Compensating bearing rails are used for load bearing of radial forces and, in combination with fixed bearing rails as support bearings for occurring moment loads.



Fig. 3

### System (T+U-System)

A T and U-rail used together offers compensation for deviations in parallelism and tolerances in the mounting structure.



Fig. 4

### Rollers

Concentric and eccentric radial ball bearings made of stainless or roller bearing steel are available for each slider. Roller sealing is dependent on the material: 2RS rubber seals or 2Z steel shields. All rollers are lubricated for life.



Fig. 5

## Technical data

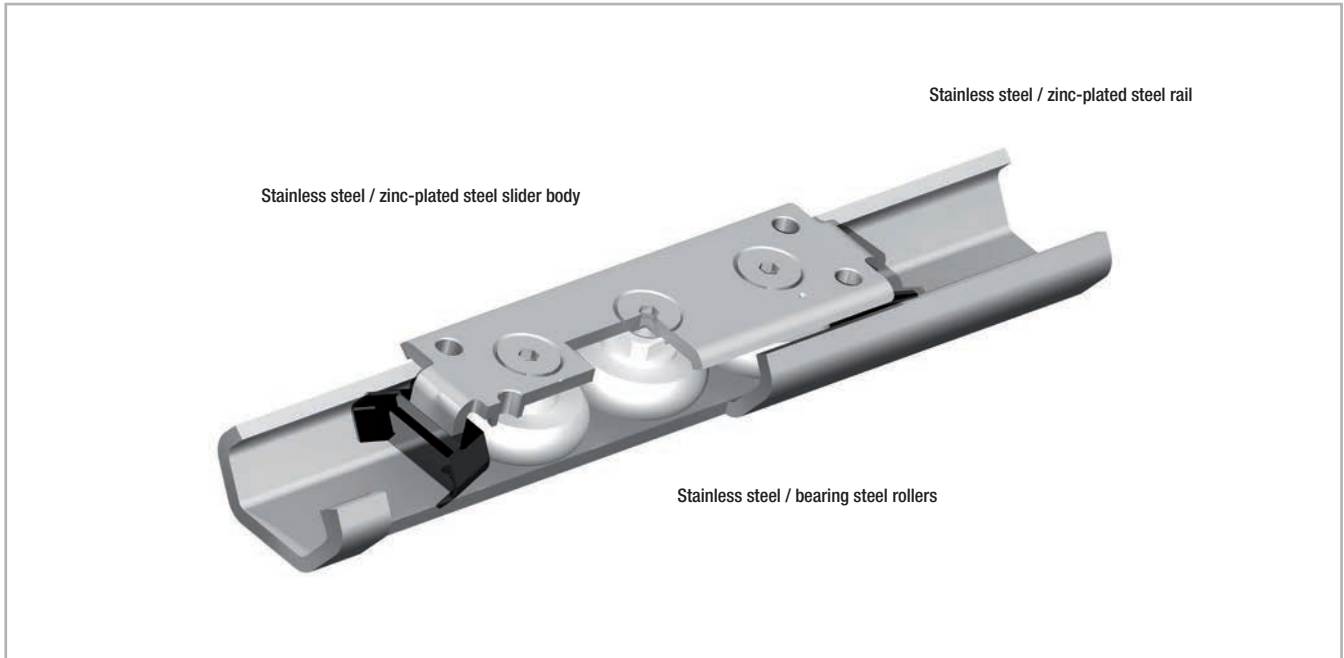

Fig. 6

### Performance characteristics:

- Available sizes: 20, 30, 45
- Max. slider operating speeds in the linear bearing rails: 1.5 m/s (59 in/s) (depending on application)
- Max. acceleration: 2 m/s<sup>2</sup> (78 in/s<sup>2</sup>) (depending on application)
- Max. traverse: 3,060 mm (120 in) (depending on size)
- Max. radial load capacity: 1,740 N (per slider)
- Temperature range for stainless steel rails: -30 °C to +100 °C (-22 °F to +212 °F), or steel rails: -30 °C to +120 °C (-22 °F to +248 °F)
- Available rail lengths from 160 mm to 3,120 mm (6.3 in to 122 in) in 80-mm increments (3.15 in)
- Rollers lubricated for life
- Roller seal/shield:  
CEX... Sliders => 2RS (splashproof seal),  
CES... Sliders => 2Z (dust cover seal)
- Material: Stainless steel rails TEX... / UEX... 1.4404 (AISI 316L),  
Steel rails TES... / UES... zinc-plated ISO 2081
- Material rollers: Stainless steel 1.4110 (AISI 440)

### Remarks:

- The sliders are equipped with rollers that are in alternating contact with both sides of the raceway. Markings on the body around the outer roller pins indicate the correct arrangement of the rollers to the external load.  
Important note: Both outside rollers carry the radial load.
- With a simple adjustment of the eccentric roller, clearance or the desired preload can be set on the rail and slider.
- Sliders of Version 1 (with compact body) come standard with plastic wipers for cleaning the raceways.
- Wipers for sliders of Versions 2 and 3 on request (see pg. XR-6 and XR-7).
- We do not recommend combining (stringing together) the rails.
- Recommended fixing screws according to ISO 7380 with low head height or TORX® screws on request.

## > Load capacities

### Fixed bearings

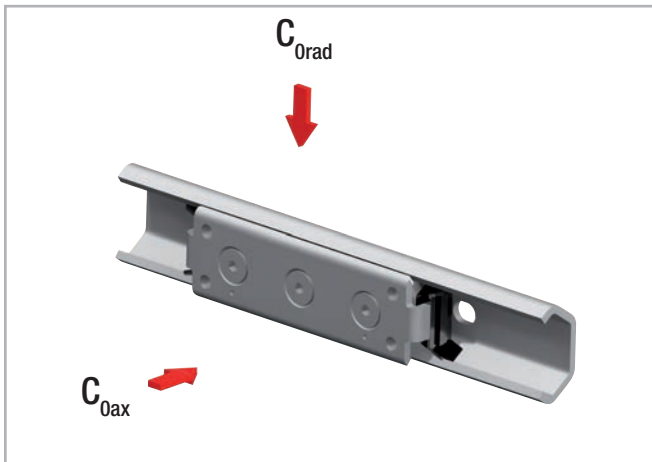

Fig. 7

Configuration	$C_{Orad}$ [N]	$C_{Oax}$ [N]
TEX-20 – CEX20	300	170
TEX-30 – CEX30	800	400
TEX-45 – CEX45	1600	860
TES-20 – CES20	326	185
TES-30 – CES30	870	435
TES-45 – CES45	1740	935

Tab. 1

Resulting moment loads must be absorbed through the use of two sliders

### Compensating bearings

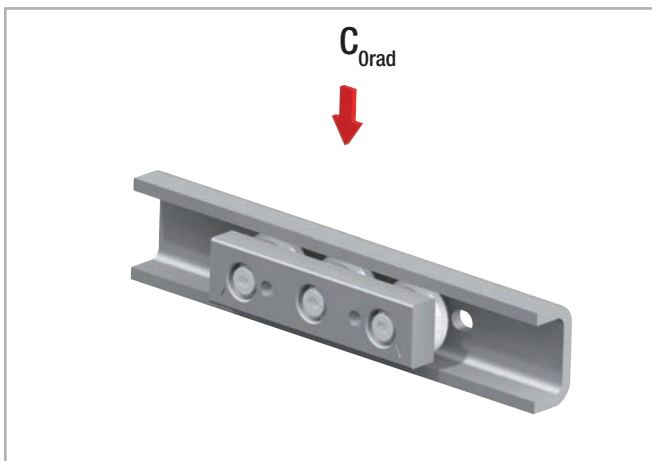

Fig. 8

Configuration	$C_{Orad}$ [N]
UEX-20 – CEXU20	300
UEX-30 – CEXU30	800
UEX-45 – CEXU45	1600
UES-20 – CESU20	326
UES-30 – CESU30	870
UES-45 – CESU45	1740

Tab. 2

X  
R

# Product dimensions



## > Fixed rails

Rail (TEX = stainless steel / TES = zinc-plated steel)

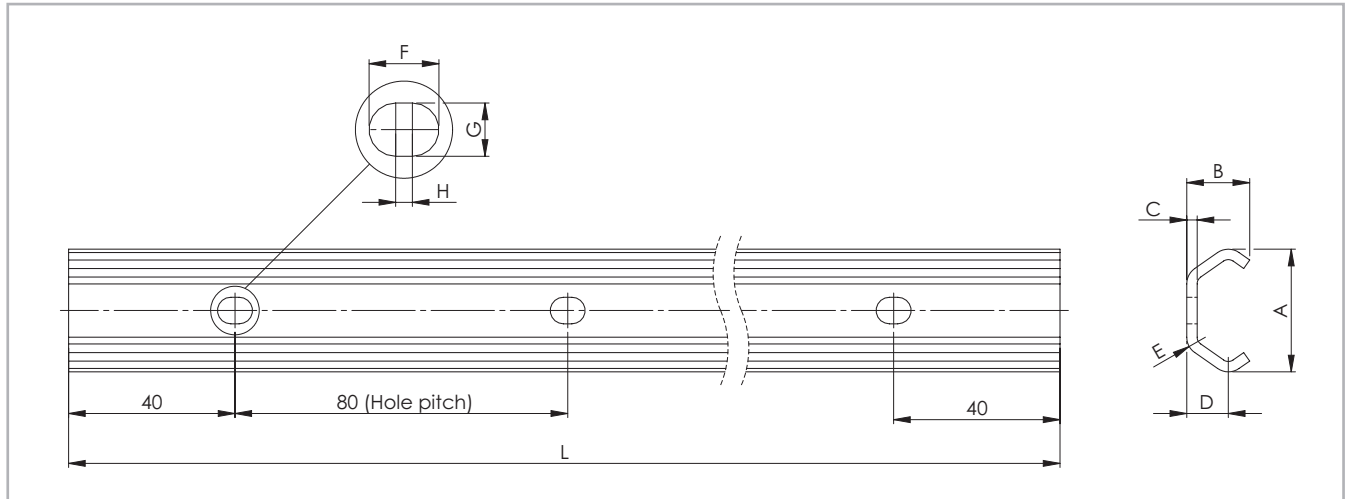

Fig. 9

Rail type	Size	A [mm]	B [mm]	C [mm]	D [mm]	E [mm]	F [mm]	G [mm]	H [mm]	Holes for screws	Weight [kg/m]
TEX	20	19.2	10	2	7	3	7	5	2	M4	0.47
	30	29.5	15	2.5	10	4.5	8.4	6.4	2	M5	0.90
TES	45	46.4	24	4	15.5	6.5	11	9	2	M8	2.29

Tab. 3

Rail type	Standard length L [mm]
TEX	160 - 240 - 320 - 400 - 480 - 560 - 640 - 720 - 800 - 880 - 960 - <b>1040</b> - 1120 - 1200 - 1280 - 1360 - 1440 - 1520 - 1600 - 1680
TES	- 1760 - 1840 - 1920 - 2000 - <b>2080</b> - 2160 - 2240 - 2320 - 2400 - 2480 - 2560 - 2640 - 2720 - 2800 - 2880 - 2960 - 3040 - <b>3120</b>

Tab. 4

Please specify hole pattern separately  
 Special lengths or pitches available upon request, please contact the sales department  
 The highlighted rail lengths are available from stock



**Slider (CEX = stainless steel / CES = zinc-plated steel)**

Version 1 (with compact body for fixed rails)

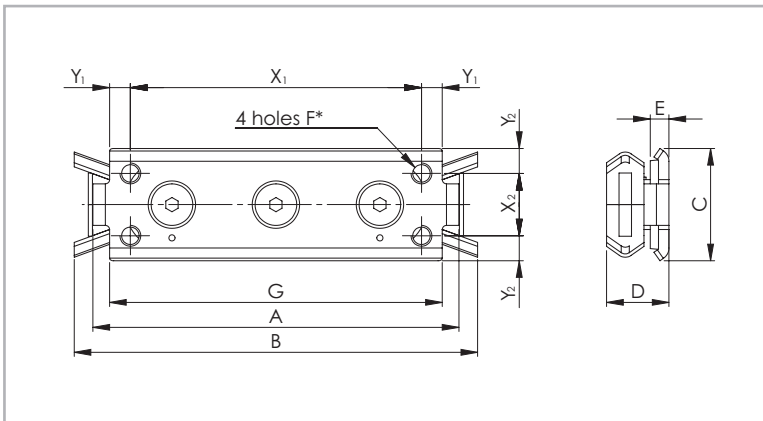

Fig. 10

\* For size 20: 2 M5 holes on the centreline with distance  $X_1$

Slider type	Size	A [mm]	B [mm]	C [mm]	D [mm]	E [mm]	F	G [mm]	$X_1$ [mm]	$Y_1$ [mm]	$X_2$ [mm]	$Y_2$ [mm]	Weight [kg]
CEX20-80 CES20-80	20	80	90	18	11.5	5.5	M5	71	60	5,5	-	9	0.05
CEX30-88 CES30-88	30	88	97	27	15	4.5	M5	80	70	5	15	6	0.11
CEX45-150 CES45-150	45	150	160	40	22	4	M6	135	120	7.5	23	8.5	0.40

Tab. 5

Version 2 (with solid body for fixed rails)

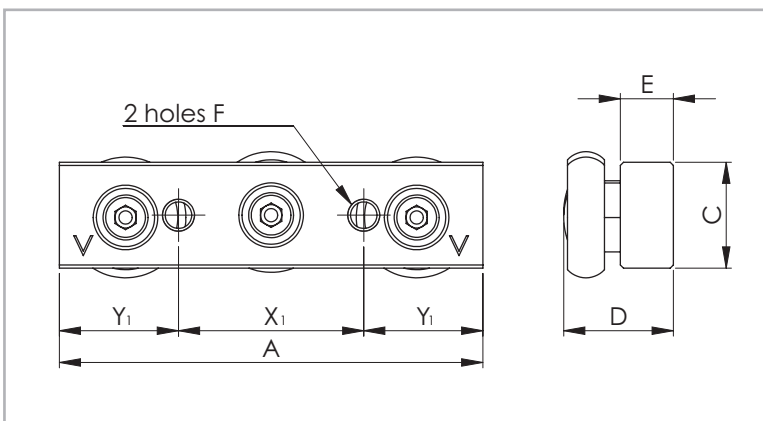

Fig. 11

Slider version with wipers on request

Slider type	Size	A [mm]	C [mm]	D [mm]	E [mm]	F	$X_1$ [mm]	$Y_1$ [mm]	Weight [kg]
CEX20-60 CES20-60	20	60	10	13	6	M5	20	20	0.04
CEX30-80 CES30-80	30	80	20	20.7	10	M6	35	22.5	0.17
CEX45-120 CES45-120	45	120	25	28.9	12	M8	55	32.5	0.47

Tab. 6

## > Compensating rails

Rail (UEX = stainless steel / UES = zinc-plated steel)

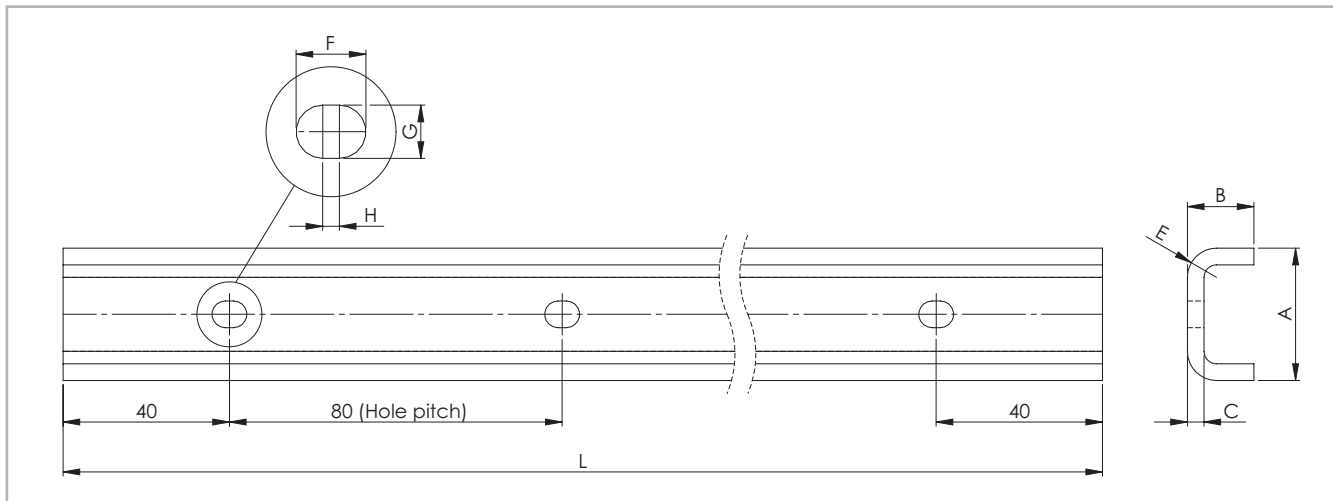

Fig. 12

Rail type	Size	A [mm]	B [mm]	C [mm]	E [mm]	F [mm]	G [mm]	H [mm]	Holes for screws	Weight [kg/m]
UEX	20	20.5	11	3	5.5	7	5	2	M4	0.77
	30	31.8	16	4	7	8.4	6.4	2	M5	1.39
UES	45	44.8	24.5	4.5	9.5	11	9	2	M8	2.79

Tab. 7

Rail type	Standard length L [mm]
UEX	160 - 240 - 320 - 400 - 480 - 560 - 640 - 720 - 800 - 880 - 960 - <b>1040</b> - 1120 - 1200 - 1280 - 1360 - 1440 - 1520 - 1600 - 1680
UES	- 1760 - 1840 - 1920 - 2000 - <b>2080</b> - 2160 - 2240 - 2320 - 2400 - 2480 - 2560 - 2640 - 2720 - 2800 - 2880 - 2960 - 3040 - <b>3120</b>

Tab. 8

Please specify hole pattern separately  
 Special lengths or pitches available upon request, please contact the sales department  
 The highlighted rail lengths are available from stock

**Slider (CEXU = stainless steel / CESU = zinc-plated steel)**

Version 3 (with solid body for compensating rail)

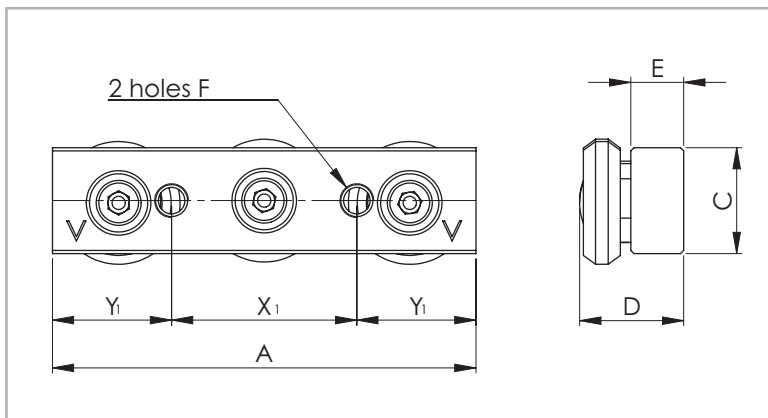

Slider version with wipers on request

Fig. 13

Slider type	Size	A [mm]	C [mm]	D [mm]	E [mm]	F [mm]	X <sub>1</sub> [mm]	Y <sub>1</sub> [mm]	Weight [kg]
CEXU20-60 CESU20-60	20	60	10	11.85	6	M5	20	20	0.04
CEXU30-80 CESU30-80	30	80	20	19.9	10	M6	35	22.5	0.16
CEXU45-120 CESU45-120	45	120	25	26.4	12	M8	55	32.5	0.45

Tab. 9

> Mounted sliders and rails

Fixed rails

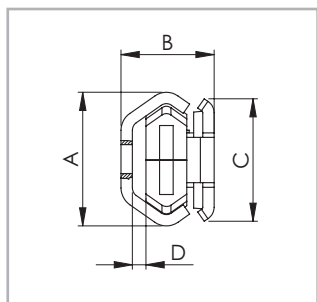

Fig. 14

Version 1  
(Slider with compact body)

Configuration	A [mm]	B [mm]	C [mm]	D [mm]
TEX-20 – CEX20-80 TES-20 – CES20-80	19.2	16	18	2.5
TEX-30 – CEX30-88 TES-30 – CES30-88	29.5	20.5	27	3.5
TEX-45 – CEX45-150 TES-45 – CES45-150	46.4	31	40	5

Tab. 10

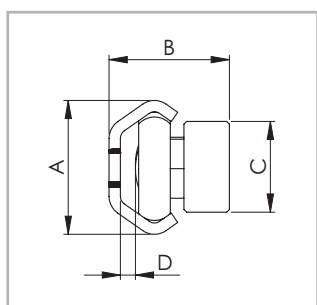

Fig. 15

Version 2  
(Slider with solid body)

Configuration	A [mm]	B [mm]	C [mm]	D [mm]
TEX-20 – CEX20-60 TES-20 – CES20-60	19.2	17.8	10	2.6
TEX-30 – CEX30-80 TES-30 – CES30-80	29.5	26.5	20	3.3
TEX-45 – CEX45-120 TES-45 – CES45-120	46.4	38	25	5.1

Tab. 11

Compensating rails

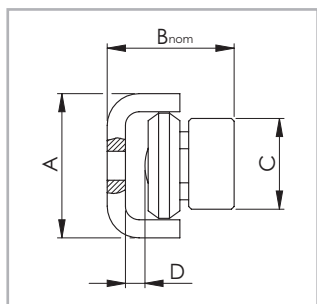

Fig. 16

Version 3  
(Slider with solid body)

Configuration	A [mm]	B <sub>nom</sub> [mm]	C [mm]	D [mm]
UEX-20 – CEXU20-60 UES-20 – CESU20-60	20.5	18.25 ± 0.6	10	3.4
UEX-30 – CEXU30-80 UES-30 – CESU30-80	31.8	27.95 ± 1.0	20	4.05
UEX-45 – CEXU45-120 UES-45 – CESU45-120	44.8	37.25 ± 1.75	25	6.35

Tab. 12

# Accessories



## Rollers

### Version 1

(Slider with compact body for fixed rails)

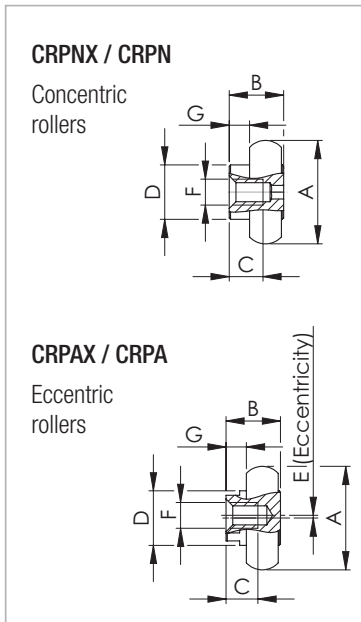

Fig. 17

Roller type	for slider	A [mm]	B [mm]	C [mm]	D [mm]	E [mm]	F	G [mm]	Weight [kg]
CRPNX20-2RS	CEX20-80	14	8.5	6	8	-	M4	4.0	0.006
CRPN20-2Z	CES20-80								
CRPAX20-2RS	CEX20-80					0.5			
CRPA20-2Z	CES20-80								
CRPNX30-2RS	CEX30-88	22.8	12	7	12	-	M5	4.5	0.02
CRPN30-2Z	CES30-88								
CRPAX30-2RS	CEX30-88					0.6			
CRPA30-2Z	CES30-88								
CRPNX45-2RS	CEX45-150	35.6	18	12	16	-	M6	6.0	0.068
CRPN45-2Z	CES45-150								
CRPAX45-2RS	CEX45-150					0.8			
CRPA45-2Z	CES45-150								

Load rate per roller: radial 50 %, axial 33 % of the given slider load rate  
2RS (splashproof seal for CEX slider), 2Z (dust cover seal for CES slider)

Tab. 13

### Version 2

(Slider with solid body for fixed rails)

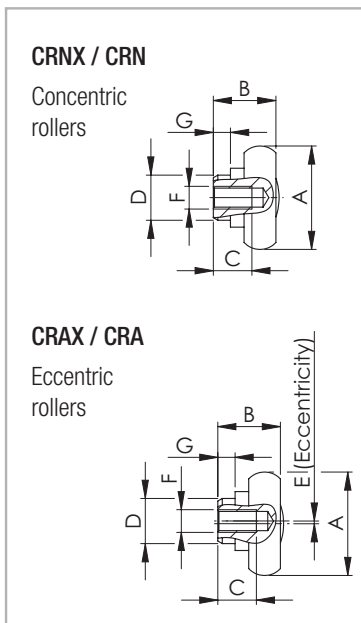

Fig. 18

Roller type	for slider	A [mm]	B [mm]	C [mm]	D [mm]	E [mm]	F	G [mm]	Weight [kg]
CRNX20-2RS	CEX20-60	14	8.7	6	6	-	M4	1.8	0.006
CRN20-2Z	CES20-60								
CRAX20-2RS	CEX20-60					0.5			
CRA20-2Z	CES20-60								
CRNX30-2RS	CEX30-80	22.8	14	9	10	-	M5	3.8	0.022
CRN30-2Z	CES30-80								
CRAX30-2RS	CEX30-80					0.6			
CRA30-2Z	CES30-80								
CRNX45-2RS	CEX45-120	35.6	20.5	14.5	12	-	M6	4.5	0.07
CRN45-2Z	CES45-120								
CRAX45-2RS	CEX45-120					0.8			
CRA45-2Z	CES45-120								

Load rate per roller: radial 50 %, axial 33 % of the given slider load rate  
2RS (splashproof seal for CEX slider), 2Z (dust cover seal for CES slider)

Tab. 14

Version 3

(Slider with solid body for compensating rails)

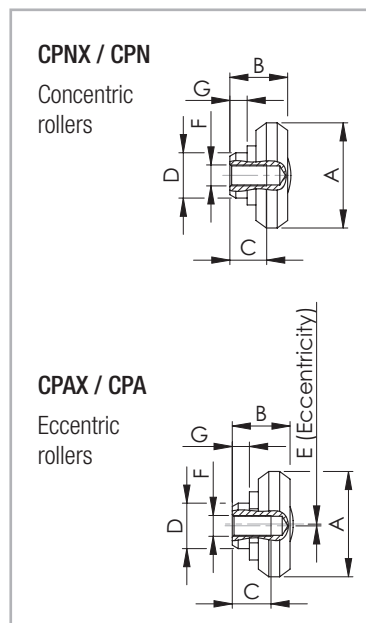

Fig. 19

Roller type	for slider	A [mm]	B [mm]	C [mm]	D [mm]	E [mm]	F	G [mm]	Weight [kg]
CPNX20-2RS	CEXU20-60	14	7.35	5.5	6	-	M4	1.8	0.004
CPN20-2Z	CESU20-60								
CPAX20-2RS	CEXU20-60					0.4			
CPA20-2Z	CESU20-60								
CPNX30-2RS	CEXU30-80	23.2	13	7	10	-	M5	3.8	0.018
CPN30-2Z	CESU30-80								
CPAX30-2RS	CEXU30-80					0.6			
CPA30-2Z	CESU30-80								
CPNX45-2RS	CEXU45-120	35	18	12	12	-	M6	4.5	0.06
CPN45-2Z	CESU45-120								
CPAX45-2RS	CEXU45-120					0.8			
CPA45-2Z	CESU45-120								

Load rate per roller: radial 50 % of given slider load rate  
 2RS (splashproof seal for CEX slider), 2Z (dust cover seal for CES slider)

Tab. 15

> Fixing screws

We recommend fixing screws according to ISO 7380 with low head height or TORX® screws (see fig. 20) on request.

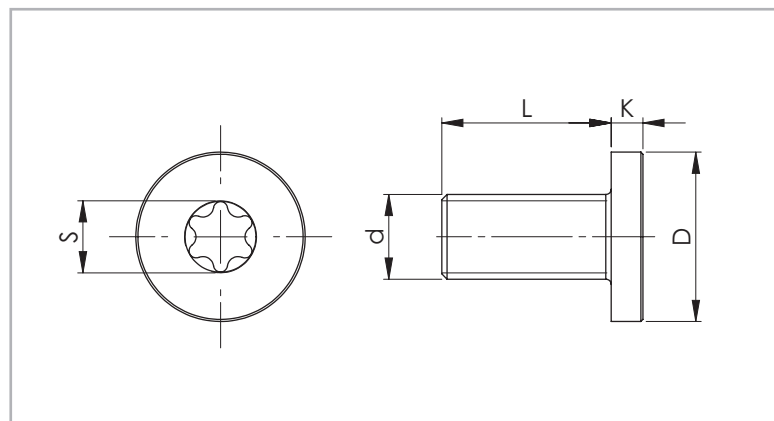

Fig. 20

Rail size	Screw type	d	D [mm]	L [mm]	K [mm]	S	Tightening torque [Nm]
20	M4 x 8	M4 x 0.7	8	8	2	T20	3
30	M5 x 10	M5 x 0.8	10	10	2	T25	9
45	M8 x 16	M8 x 1.25	16	16	3	T40	22

Tab. 16

## Technical instructions



### > Lubrication

All radial ball bearing rollers in the X-Rail series are lubricated for life. It is advisable to lubricate the raceways with specific bearing grease. The interval between lubrication treatments depends mainly on environmental conditions, bearing speed and temperature.

Under normal conditions, it is advisable to lubricate locally after 100 km of use or after six months of service. In case of critical applications, lubrication treatments should be more frequent. Before lubricating, remember to clean the raceway surfaces carefully. We advise using a lithium grease of medium consistency for rolling-element bearings.

Different lubricants are available on request for special applications:

- FDA-approved lubricant for use in the food industry

- specific lubricant for clean rooms
- specific lubricant for the marine technology sector
- specific lubricant for high and low temperatures

For specific information, contact Rollon technical support.

Under normal conditions, correct lubrication:

- reduces friction
- reduces wear
- reduces stress on contact surfaces due to elastic deformation
- reduces noise during operation
- increases the regularity of the rolling movement

### > T+U-System

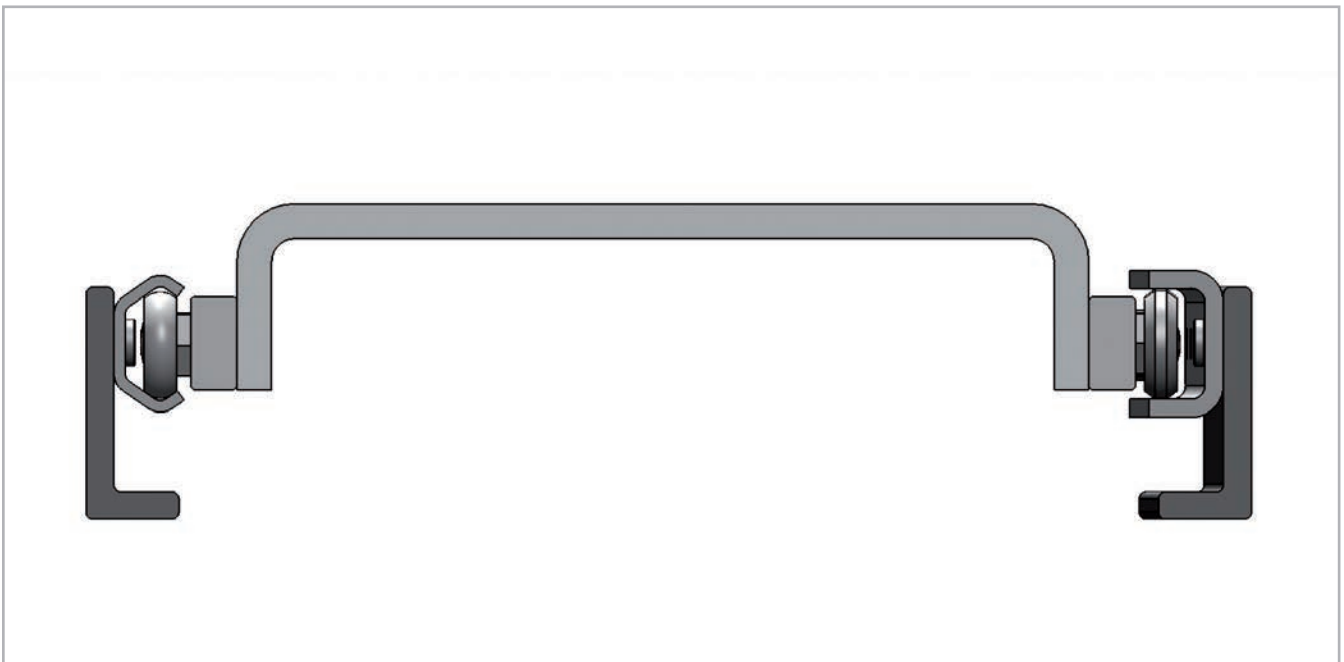

Fig. 21

#### Solves axial deviations in parallelism

Mounting two linear bearing rails in a parallel manner is always important but rarely easy. Distortions in axial alignment can drastically reduce the life of the rails. These distortions can bind and overload sliders. Rollon offers an outstanding solution for the alignment of dual track carriages. Using shaped and flat raceways it is possible to avoid axial deviation in parallelism of the mounting surfaces without additional modifications of those surfaces. T+U rails easily address these alignment issues to create an economical parallel rail system.

In a T+U-System, the slider in the T rail carries axial and radial loads and guides the movement of the U, which has lateral freedom.

U rails have flat parallel raceways that allow free lateral movement of the sliders. The maximum freedom a slider in the U rail can offer can be calculated using the values  $S_1$  and  $S_2$  (see pg. XR-14, fig. 22, tab. 19). With nominal value  $B_{nom}$  as the starting point,  $S_1$  indicates the maximum allowed movement into the rail, while  $S_2$  represents the maximum offset towards the outside of the rail.

If the length of the guide rail is known, the maximum allowable angle deviation of the mounting surface (see pg. XR-14, fig. 23) can be obtained. In this case the slide in the U rail has the freedom to travel from the innermost position  $S_1$  to the outermost position  $S_2$ .

Maximum offset

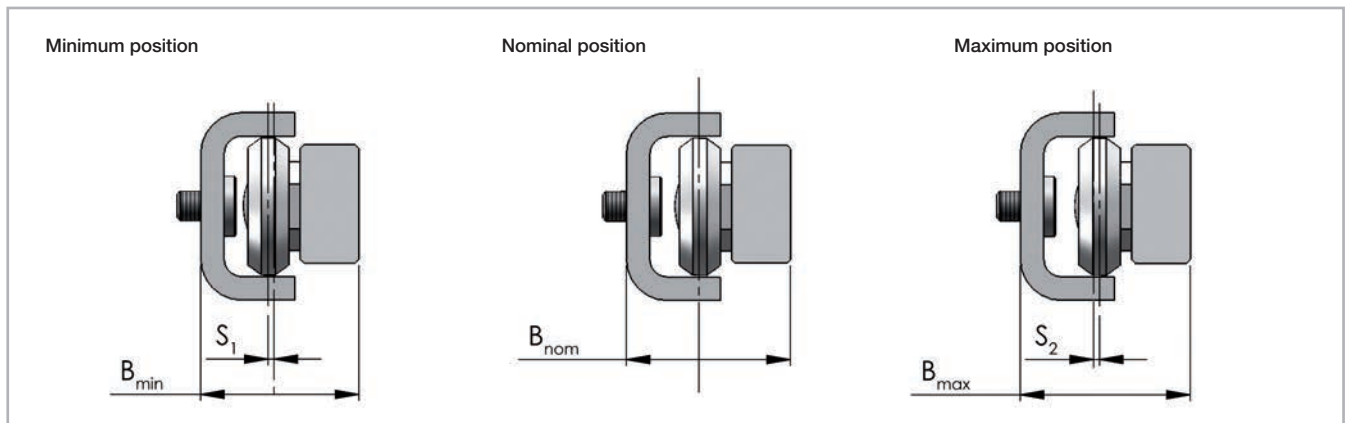

Fig. 22

Slider type (Version 3 with solid body)	S <sub>1</sub> [mm]	S <sub>2</sub> [mm]	B <sub>min</sub> [mm]	B <sub>nom</sub> [mm]	B <sub>max</sub> [mm]
CEXU.../CESU20-60	0.6	0.6	17.65	18.25	18.85
CEXU.../CESU30-80	1	1	26.95	27.95	28.95
CEXU.../CESU45-120	1.75	1.75	35.50	37.25	39

Tab. 17

Guideline for the maximum angle deviation  $\alpha$ , achievable with the longest guide rail

$$\alpha = \arctan \frac{S^*}{L}$$

S\* = sum of S<sub>1</sub> and S<sub>2</sub>  
L = length of the rail

Fig. 23

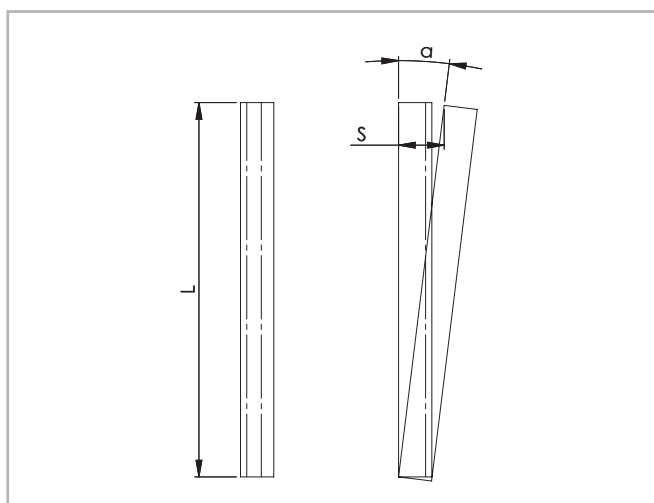

Fig. 24

Size	Rail length [mm]	Offset S* [mm]	Angle $\alpha$ [°]
20	3120	1.2	0.022
30	3120	2	0.037
45	3120	3.5	0.064

Tab. 18



## > Setting preload

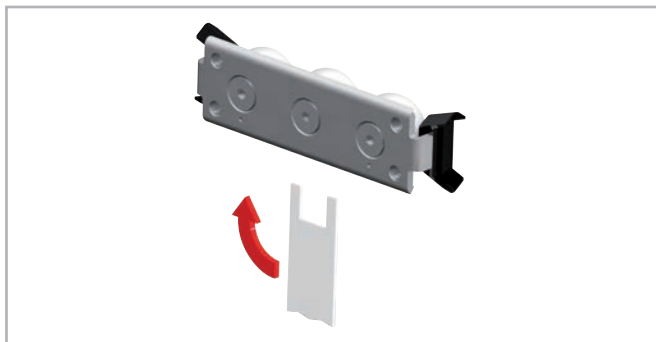

Fig. 25

If the product is delivered with the sliders in the rails, the sliders are already preloaded. If delivered separately, or if the sliders need to be installed in another rail, the sliders must be readjusted. In this case, follow the instructions below:

- Wipe the raceways of any dirt and debris.
- If necessary, remove existing wipers and insert the sliders into the rails. Slightly loosen the fixing screw of the center roller pin.
- Position the slider(s) at the ends of the rail.
- For the U rails there must be a thin support (e.g. set key) under the ends of the slider body to ensure the horizontal alignment of the slider in the flat raceways.
- The included special flat key is inserted from the side between the rail and the slider and inserted onto the hexagonal or square shaft of the eccentric pin to be adjusted (see fig. 25).

Size	Tightening torque [Nm]
20	3
30	7
45	12

Tab. 19

- By turning the flat key clockwise, the eccentric roller is pressed against the upper raceway, thereby removing clearance and setting the correct preload. During this process, absence of play is desired; avoid setting a preload that is so high that it generates high friction and reduces service life.
- Hold the roller with the adjustment key in the desired position and carefully tighten the fixing screw. The exact tightening torque will be checked later.
- Move the slider in the rail and check the preload over the entire length of the rail. It should move easily and the slider should not have play at any location of the rail.
- Tighten the fixing screw with the specified tightening torque (see tab. 19), while holding the flat key and maintaining the angle position of the roller so as to not change the preload while tightening the screw. It is recommended to use thread locking compound.
- Now re-attach the existing wipers if desired.

## > Use of radial ball bearing rollers

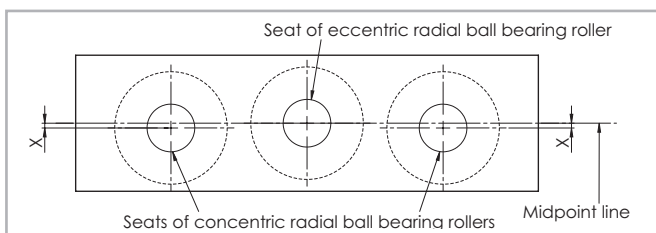

Fig. 26

Slider size	X [mm]
20	0,60
30	0,65
45	0,60

Tab. 20

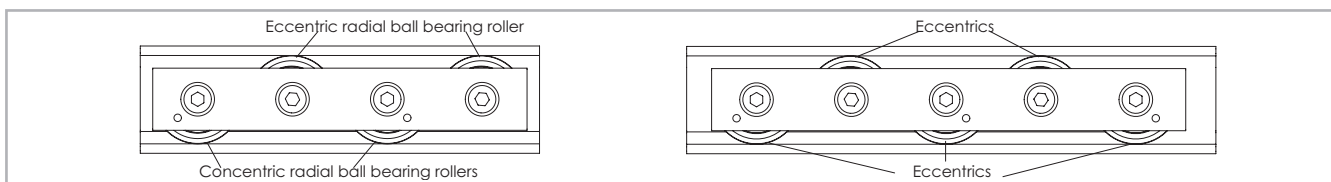

Fig. 27

If purchasing "Radial ball bearing rollers" to install on your own structure (see from p. XR-10 to XR-12) we advise:

- Using a maximum of 2 concentric radial ball bearing rollers

- Offset the seats of the concentric radial ball bearing rollers with respect to those of the eccentric radial ball bearing rollers according to the table (tab. 20).

# Ordering key



## > Rail / slider system

TEX-	960	/1/	CEX20-60	-2RS	
				Roller seal	<i>see pg. XR-4 Performance characteristics</i>
				Slider type	<i>see pg. XR-7, tab. 5 and 6/ pg. XR-9, tab. 9</i>
				Number of sliders in one rail	
				Rail length in mm	<i>see pg. XR-6, tab. 4 / pg.XR-8, tab. 8</i>
				Rail type	<i>see pg. XR-6, tab. 3 / pg. XR-8, tab. 7</i>

Ordering example: TEX-00960/1/CEX20-060-2RS

Hole pitch: 40-11x80-40

Notes on ordering: The rail length codes are always 5 digits, the slider length codes are always 3 digits; use zeroes as a prefix when lengths are shorter

## > Rail

TEX-	30-	960	
		Rail length in mm	<i>see pg. XR-6, tab. 4 / pg. XR-8, tab. 8</i>
		Size	<i>see pg. XR-6, tab. 3 / pg. XR-8, tab. 7</i>
		Rail type	<i>see pg. XR-6, tab. 5 / pg.XR-8, tab. 7</i>

Ordering example: TEX-30-00960

Hole pattern: 40-11x80-40

Notes on ordering: The rail length codes are always 5 digits; use zeroes as a prefix when lengths are shorter

## > Slider

CES30-80	-2Z	
	Roller seal	<i>see pg. XR-6 Performance characteristics</i>
	Slider type	<i>see pg. XR-7, tab. 5 and 6/ pg. XR-9, tab. 9</i>

Ordering example: CES30-080-2Z

Notes on ordering: The slider length codes are always 3 digits; use zeroes as a prefix when lengths are shorter

## > Accessories

### Roller pins

<b>CRPAX</b>	<b>45</b>	<b>-2RS</b>	
		Roller seal	<i>see pg. XR-6 Performance characteristics</i>
	Size	<i>see pg. XR-11, tab. 13-15</i>	
Roller type	<i>see pg. XR-11, tab. 13-15</i>		

Ordering example: CRPAX45-2RS

### Fixing screws

Rail type	Size	Ordering description
TEX / UEX	20	TORX®-screw TC 18 M4x8 NIC
	30	TORX®-screw TC 28 M5x10 NIC
	45	TORX®-screw TC 43 M8x16 NIC
TES / UES	20	TORX®-screw TC 18 M4x8
	30	TORX®-screw TC 28 M5x10
	45	TORX®-screw TC 43 M8x16

*see pg. XR-12, fig. 20, tab. 16*



**ROLLON**<sup>®</sup>  
Linear Evolution

*Easyslide*

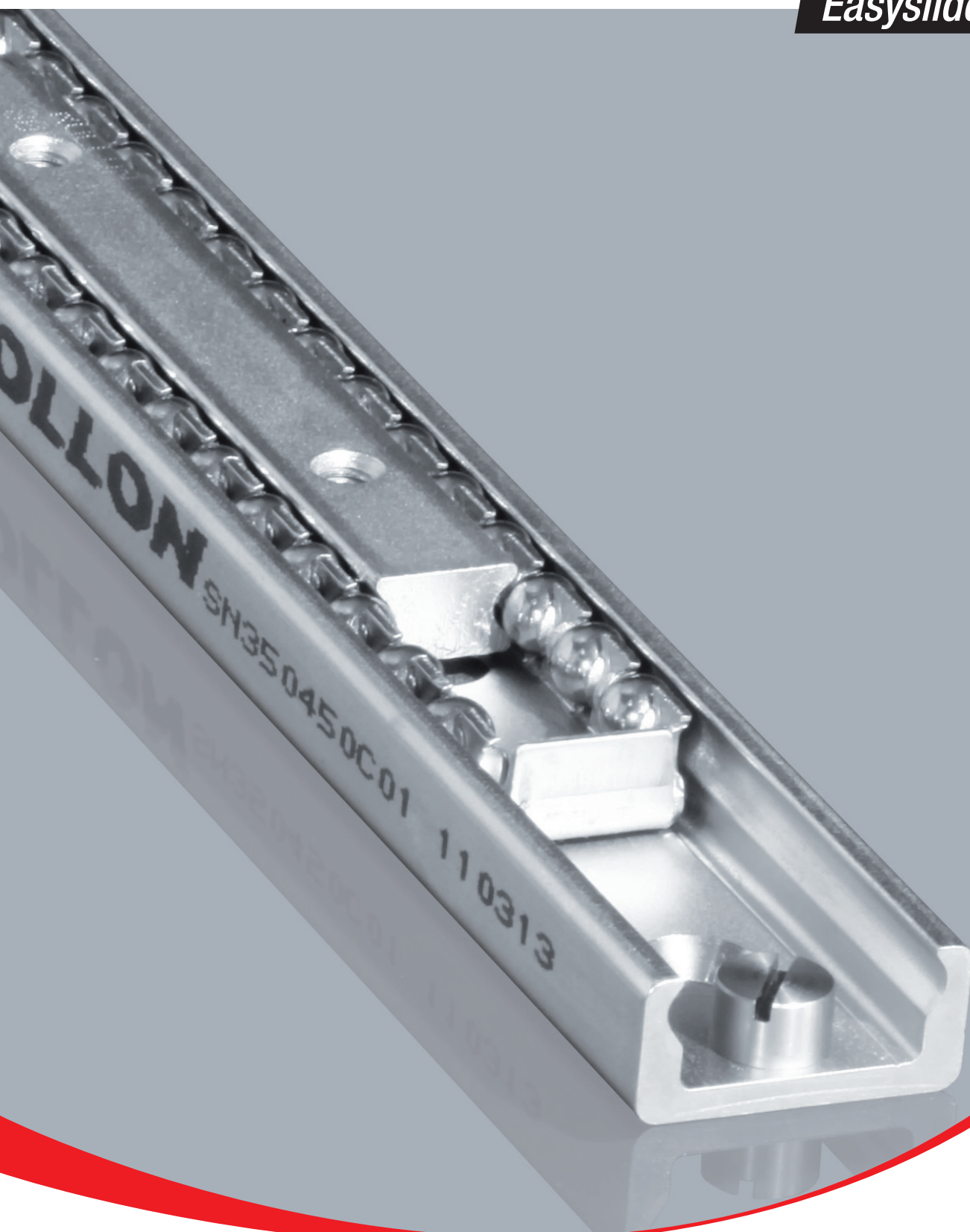

## Product explanation



- > Easyslide is a linear ball rail system (with caged ball bearings for the SN series or with recirculating ball bearings for the SNK series) with single or multiple sliders.



Fig. 1

The Easyslide series is a system of drawn steel linear rails with induction hardened raceways. The system consists of an “C” shaped linear profile rail, and one or more internal sliders with caged recirculating ball bearings.

### The most important characteristics:

- Guide rails and sliders of SN series are made of cold-drawn bearing steel
- Ball cage is made of steel for the SN series
- Balls are made of hardened bearing steel
- Raceways of the guide rails and sliders are induction hardened (ground for the SNK series)
- Long service life
- With recirculating ball bearings for the SNK series

### Preferred areas of application of the Easyslide product family:

- Transportation industry (e.g., exterior and interior rail and bus doors, seat adjustments, interior)
- Construction and machine technology (e.g., housings, protective covers)
- Medical technology (e.g., X-ray equipment, medical tables)
- Automotive technology
- Logistics (e.g., handling units)
- Packaging machines (e.g., beverage industry)
- Special machines

**SN linear bearing, version 1, with single slider**

This linear bearing consists of a guide rail and a slider that runs within the ball cage in the guide rail. High load capacities, compact cross-sections and simple and easy mounting characterize this series.



Fig. 2

**SN linear bearing, version 2, with multiple independent sliders**

Variant with several sliders, which each runs in its own ball cage, independent of each other, in the guide rail. Slider length and stroke for each slider can be different within one rail.



Fig. 3

**SN linear bearing, version 3, with multiple synchronized sliders**

Several sliders run in a common ball cage within the guide rails. The slider lengths can vary here as well and then form a total unit, which implements the corresponding stroke.



Fig. 4

**SNK series linear rails with recirculating ball bearings.**

The SNK series consists of a drawn steel C profile rail with hardened and ground raceways and of an internal slider with a recirculating ball bearing system. This product is extremely compact and boasts high load rating and great sliding properties.



Fig. 5

## Technical data

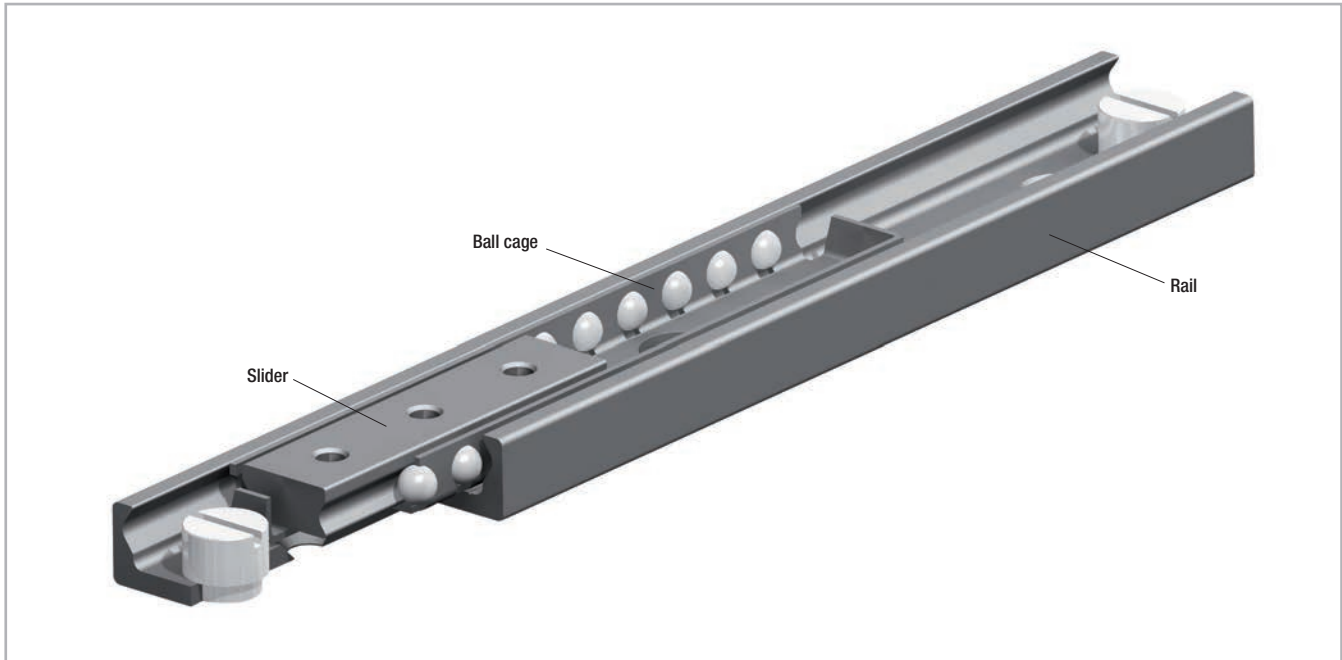

Fig. 6

### Performance characteristics:

- Available sizes for SN: 22, 28, 35, 43, 63
- Sections available for the SNK series: 43
- Inductive raceways hardened and ground for the SNK series
- Rails and sliders are made of cold-drawn bearing steel
- Balls are made of hardened bearing steel
- Max. operating speed 1.5 m/s (SNK)
- Temperature range: from -30 °C to +170 °C for the SN series  
from -20° to 70° for the SNK series
- Electrolytic zinc-plating as per ISO 2081; increased anticorrosive protection on request (see Chapter 4, Technical instructions, pg. 16 Anticorrosive protection)
- Linear accuracy 0.1 mm/m stroke
- 2 different types of preload

### Remarks:

- SN can only be horizontally mounted, high performance SNK can be horizontally and vertically mounted.
- External stops are recommended
- Fixing screws of property class 10.9 must be used for all linear bearings



# Dimensions and load capacity

> SN

SN linear bearing, version 1, with single slider

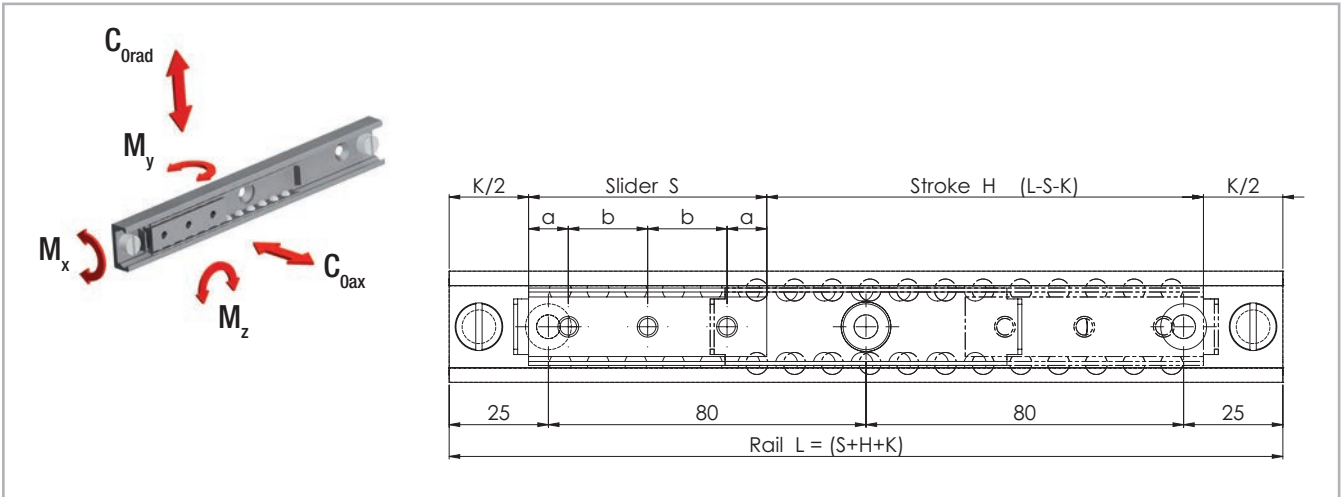

Fig. 7

To ensure that all fixing holes of the rail are accessible, S must be  $< L/2 - K$ .  
 To ensure proper smooth movement it is necessary that  $H \leq 7S$ .

Type	Size	Slider								
						Load capacities and moments				
		Length S [mm]	a [mm]	b [mm]	No. of holes	$C_{Orad}$ [N]	$C_{Oax}$ [N]	$M_x$ [Nm]	$M_y$ [Nm]	$M_z$ [Nm]
SN	22	40	10	20	2	1320	924	4.4	6	9
		60			3	1980	1386	6.7	14	20
		80			4	2640	1848	8.9	25	35
		130	25	80	2	4290	3003	14.4	65	93
		210			3	6930	4851	23.3	170	243
		290			4	9570	6699	32.2	324	463

Tab. 1

Rail			
Type	Size	Length L [mm]	K [mm]
SN	22	130 - 210 - 290 - 370 - 450 - 530 - 610 - 690 - 770 - 850 - 930 - 1010 - 1090 - 1170	30

Tab. 2

### 3 Dimensions and load capacity

Type	Size	Slider								
						Load capacities and moments				
		Length S [mm]	a [mm]	b [mm]	No. of holes	C <sub>Orad</sub> [N]	C <sub>Oax</sub> [N]	M <sub>x</sub> [Nm]	M <sub>y</sub> [Nm]	M <sub>z</sub> [Nm]
SN	28	60	10	20	3	3480	2436	17.1	24	35
		80			4	4640	3248	22.7	43	62
		130	25	80	2	7540	5278	36.9	114	163
		210			3	12180	8526	59.7	298	426
		290			4	16820	11774	82.4	569	813
		370			5	21460	15022	105.1	926	1323
		450			6	26100	18270	127.9	1370	1958

Tab. 3

Rail			
Type	Size	Length L [mm]	K [mm]
SN	28	130 - 210 - 290 - 370 - 450 - 530 - 610 - 690 - 770 - 850 - 930 - 1010 - 1090 - 1170 - 1250 - 1330 - 1410 - 1490 - 1570 - 1650	40

Tab. 4

Type	Size	Slider								
						Load capacities and moments				
		Length S [mm]	a [mm]	b [mm]	No. of holes	C <sub>Orad</sub> [N]	C <sub>Oax</sub> [N]	M <sub>x</sub> [Nm]	M <sub>y</sub> [Nm]	M <sub>z</sub> [Nm]
SN	35	130	25	80	2	9750	6825	47.2	148	211
		210			3	15750	11025	76.3	386	551
		290			4	21750	15225	105.3	736	1051
		370			5	27750	19425	134.4	1198	1711
		450			6	33750	23625	163.4	1772	2531
		530			7	39750	27825	192.5	2458	3511
		610			8	45750	32025	221.6	3256	4651

Tab. 5

Rail			
Type	Size	Length L [mm]	K [mm]
SN	35	290 - 370 - 450 - 530 - 610 - 690 - 770 - 850 - 930 - 1010 - 1090 - 1170 - 1250 - 1330 - 1410 - 1490 - 1570 - 1650 - 1730 - 1810	50

Tab. 6

Type	Size	Slider								
						Load capacities and moments				
		Length S [mm]	a [mm]	b [mm]	No. of holes	$C_{0rad}$ [N]	$C_{0ax}$ [N]	$M_x$ [Nm]	$M_y$ [Nm]	$M_z$ [Nm]
SN	43	130	25	80	2	13910	9737	96	211	301
		210			3	22470	15729	155.1	551	786
		290			4	31030	21721	214.1	1050	1500
		370			5	39590	27713	273.2	1709	2441
		450			6	48150	33705	332.3	2528	3611
		530			7	56710	39697	391.4	3507	5009
		610			8	65270	45689	450.4	4645	6636

Tab. 7

		Rail	
Type	Size	Length L [mm]	K [mm]
SN	43	290 - 370 - 450 - 530 - 610 - 690 - 770 - 850 - 930 - 1010 - 1090 - 1170 - 1250 - 1330 - 1410 - 1490 - 1570 - 1650 - 1730 - 1810 - 1890 - 1970	50

Tab. 8

Type	Size	Slider								
						Load capacities and moments				
		Length S [mm]	a [mm]	b [mm]	No. of holes	$C_{0rad}$ [N]	$C_{0ax}$ [N]	$M_x$ [Nm]	$M_y$ [Nm]	$M_z$ [Nm]
SN	63	130	25	80	2	26000	18200	238.8	394	563
		210			3	42000	29400	385.8	1029	1470
		290			4	58000	40600	532.8	1962	2803
		370			5	74000	51800	679.8	3194	4563
		450			6	90000	63000	826.7	4725	6750
		530			7	106000	74200	973.7	6554	9363
		610			8	122000	85400	1120.7	8682	12403

Tab. 9

		Rail	
Type	Size	Length L [mm]	K* [mm]
SN	63	610 - 690 - 770 - 850 - 930 - 1010 - 1090 - 1170 - 1250 - 1330 - 1410 - 1490 - 1570 - 1650 - 1730 - 1810 - 1890 - 1970	80

\* For systems of versions 2 in size 63 with two independent sliders, the K dimension changes from 80 mm to 110 mm and for each additional slider by another 30 mm

Tab. 10

Version 2 with multiple independent sliders

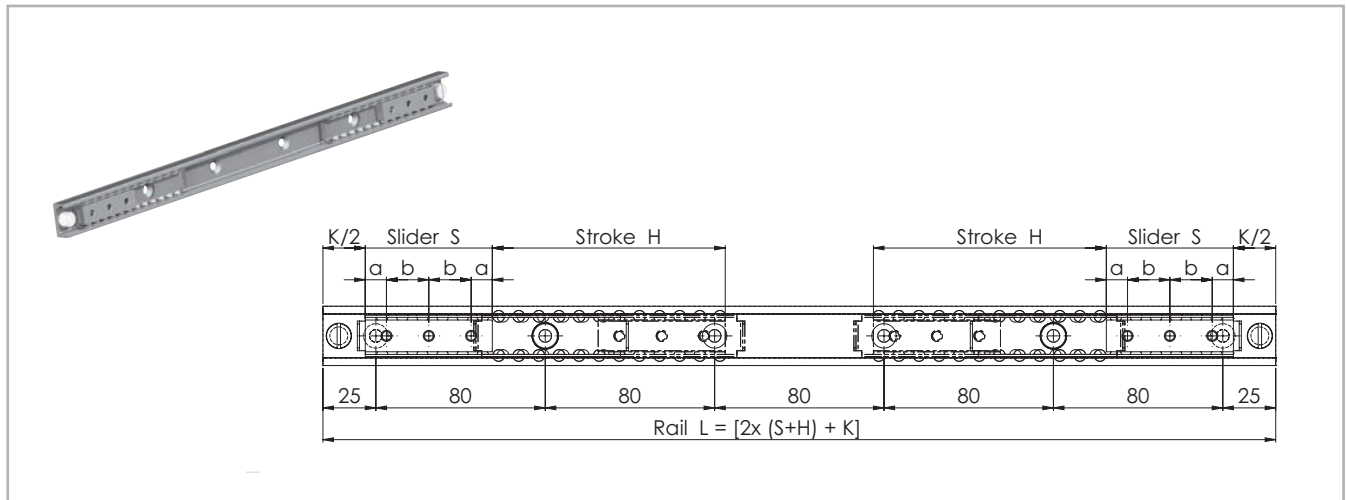

For systems of versions 2 in size 63 with two independent sliders, the K dimension changes from 80 mm to 110 mm and for each additional slider by another 30 mm

Fig. 8

Version 2 is a variant of version 1 with several independent sliders. The total load capacity is based on the number of sliders in the rail and on their lengths. The length and stroke of the individual sliders can be different.

To ensure that all fixing holes of the rail are accessible, S must be  $< L/2 - K$ .

To ensure proper smooth movement it is necessary that  $H \leq 7S$ .

Version 3 with multiple synchronized sliders

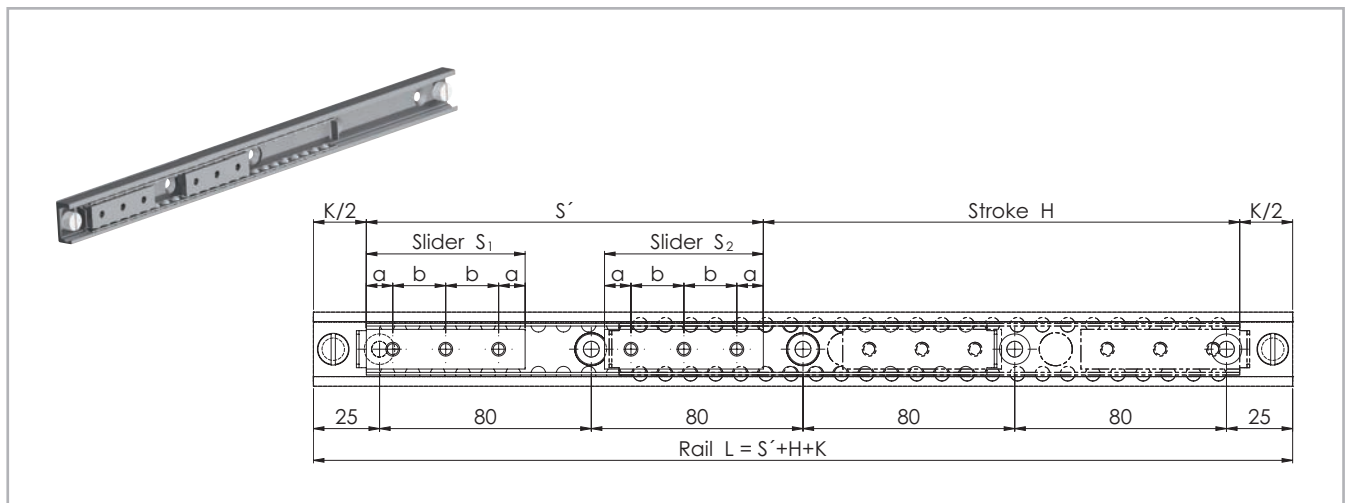

Fig. 9

Version 3 is a variant of version 1 with several synchronized sliders. The total load capacity is based on the number of sliders in the rail. The length of the individual sliders can therefore vary. To ensure that all fixing holes of the rail are accessible, S must be  $< L/2 - K$ .

To ensure proper smooth movement it is necessary that  $H \leq 7S$ .

> SN

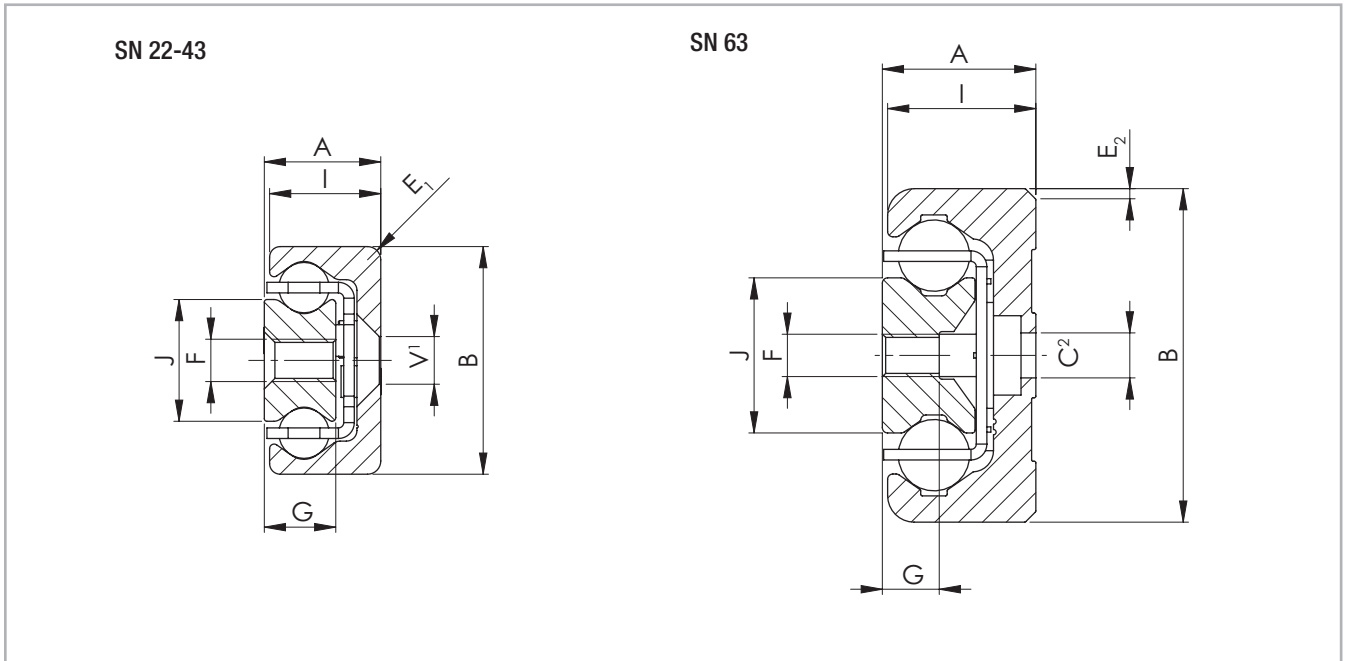

Fig. 10

<sup>1</sup> Fixing holes (V) for countersunk head screws according to DIN 7991

<sup>2</sup> Fixing holes (C) for socket cap screws according to DIN 7984. Alternative fixing with Torx® screws in special design with low head (on request)

Type	Size	Cross-section										Rail weight [kg/m]	Slider weight [kg/m]
		A [mm]	B [mm]	I [mm]	J [mm]	G [mm]	E <sub>1</sub> [mm]	E <sub>2</sub> [°]	V	C	F		
SN	22	11	22	10.25	11.3	6.5	3	-	M4	-	M4	0.7	1
	28	13	28	12.25	15	7.5	1	-	M5	-	M5	1	1.5
	35	17	35	16	15.8	10	2	-	M6	-	M6	1.8	2.5
	43	22	43	21	23	13.5	2.5	-	M8	-	M8	2.6	5
	63	29	63	28	29.3	10.5	-	2 x 45	-	M8	M8	6.1	6.9

Tab. 11

E  
S

> SNK

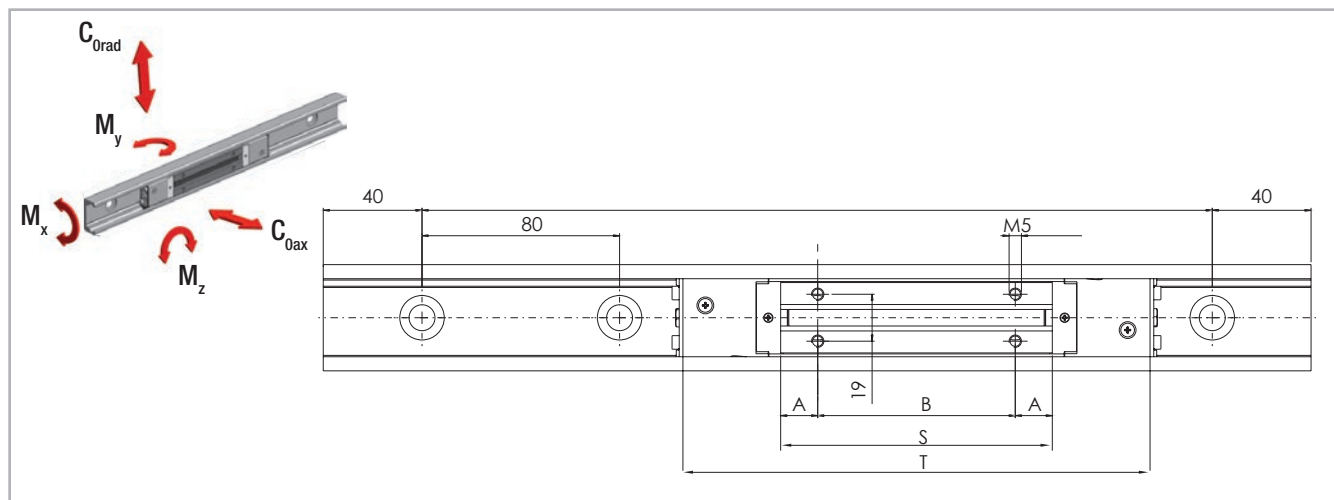

Fig.11

Type	Size	Slider									
		Load capacities and moments									
		Length S [mm]	Length T [mm]	A [mm]	B [mm]	N° of holes	C <sub>0rad</sub> [N]	C <sub>0ax</sub> [N]	M <sub>x</sub> [Nm]	M <sub>y</sub> [Nm]	M <sub>z</sub> [Nm]
SNK	43	110	198	15	80	4	7842	5489	75	95	136
		150	238	15	60	6	10858	7600	105	182	261

Tab. 12

Rail		
Type	Size	Length L [mm]
TSC/TSV	43	320-400-480-560-640-720-800-880-960-1040-1120-1200-1280-1360-1440-1520-1600-1680-1760-1840-1920-2000

For greater lengths, see the paragraph "SNK Jointed Rails on p. ES-18"

Tab. 13

> SNK

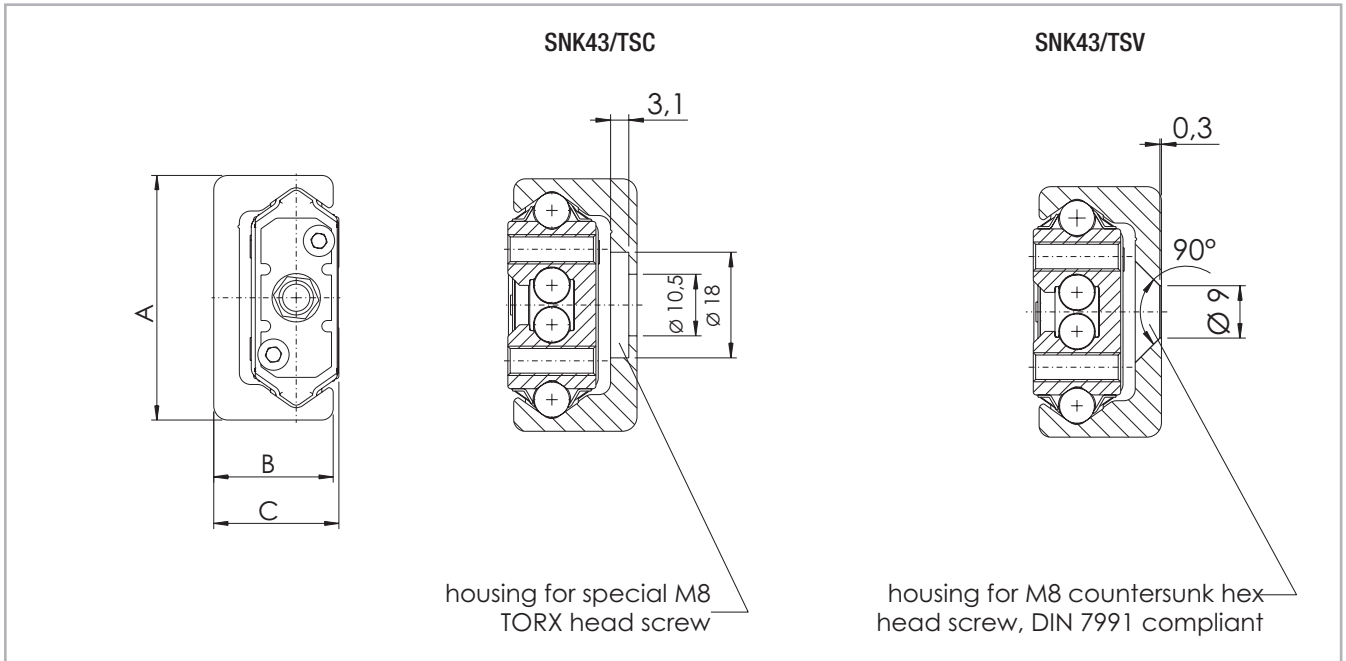

Fig. 12

Type	Size	Cross-section			Rail weight [kg/m]	Slider weight 110 [g]	Slider weight 150 [g]
		A [mm]	B [mm]	C [mm]			
TSC/TSV	43	43	21	22	2,6	360	550

Tab. 14

# Technical instructions



## > Static load

The maximum static loads of the Easyslide series are based on the slider length and are listed in the tables of the previous pages. These load capacities are valid for a loading point of forces and moments in the center of the slider (for off-center loading, see ES-13). The load capacities are independent of the position of the slider inside the rails. During the static tests the radial load capacity,  $C_{Orad}$ , the axial load capacity,  $C_{Oax}$  and

moments  $M_x$ ,  $M_y$  and  $M_z$  indicate the maximum permissible values of the loads. Higher loads negatively affect the running properties and the total mechanical strength may be compromised. A safety factor,  $S_0$ , is used to verify the static load, which takes into account the basic parameters of the application and is defined in more detail in the following table:

### Safety factor $S_0$

Neither shocks nor vibrations, smooth and low-frequency reverse, high assembly accuracy, no elastic deformations	1 - 1.5
Normal installation conditions	1.5 - 2
Shocks and vibrations, high-frequency reverse, significant elastic deformation	2 - 3.5

Tab. 15

The ratio of the actual load to maximum permissible load may be as large as the reciprocal of the accepted safety factor,  $S_0$ , at the most.

$$\frac{P_{Orad}}{C_{Orad}} \leq \frac{1}{S_0} \quad \frac{P_{Oax}}{C_{Oax}} \leq \frac{1}{S_0} \quad \frac{M_1}{M_x} \leq \frac{1}{S_0} \quad \frac{M_2}{M_y} \leq \frac{1}{S_0} \quad \frac{M_3}{M_z} \leq \frac{1}{S_0}$$

Fig. 13

The formulas above apply for a single load case. If there are two or more of the described forces simultaneously, the following check must be made:

$$\frac{P_{Orad}}{C_{Orad}} + \frac{P_{Oax}}{C_{Oax}} + \frac{M_1}{M_x} + \frac{M_2}{M_y} + \frac{M_3}{M_z} \leq \frac{1}{S_0}$$

- $P_{Orad}$  = effective radial load
- $C_{Orad}$  = permissible radial load
- $P_{Oax}$  = effective axial load
- $C_{Oax}$  = permissible axial load
- $M_1$  = effective moment in the x-direction
- $M_x$  = permissible moment in the x-direction
- $M_2$  = effective moment in the y-direction
- $M_y$  = permissible moment in the y-direction
- $M_3$  = effective moment in the z-direction
- $M_z$  = permissible moment in the z-direction

Fig. 14



**Off-center load P of the slider (SN series):**

For an off-center load of the slider, the different load distribution on the balls must be accounted for with a reduction of the load capacity C. As shown in the diagram to the right, this reduction of the distance, d, from the loading point is dependent on the slider center. The value, q, is the position factor, the distance, d, is expressed in fractions of slider length S. The permissible load, P, decreases as follows:

$P = q \cdot C_{Orad}$	for a radial load
$P = q \cdot C_{Oax}$	for an axial load

Fig. 15

For the static load and the service life calculation,  $P_{Orad}$  and  $P_{Oax}$  must be replaced by the equivalent values calculated as follows (see fig. 16):

$P_{Orad} = \frac{P}{q}$	if the external load, P, acts radially
$P_{Oax} = \frac{P}{q}$	if the external load, P, acts axially

Fig. 16

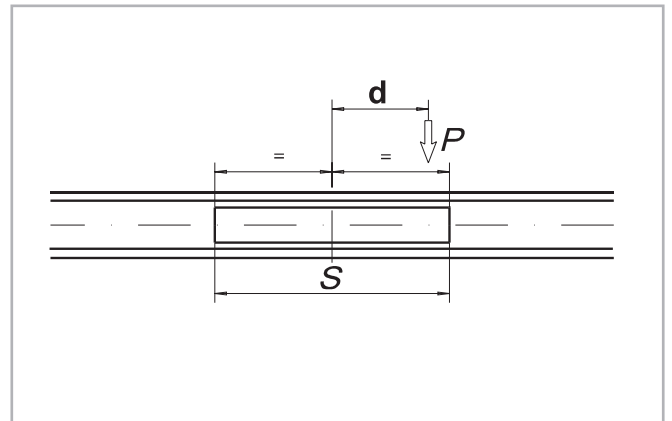

Fig. 17

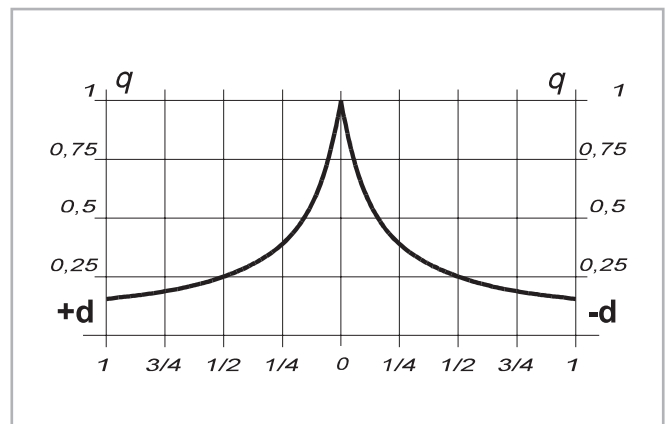

Fig. 18

## > Service life

The service life of a linear bearing depends on several factors, such as effective load, operating speed, installation precision, occurring impacts and vibrations, operating temperature, ambient conditions and lubrication. The service life is defined as the time span between initial operation and the first fatigue or wear indications on the raceways.

In practice, the end of the service life must be defined as the time of bearing decommissioning due to its destruction or extreme wear of a component.

This is taken into account by an application coefficient ( $f_i$  in the formula below), so the service life consists of:

### Series SN

$$L_{km} = 100 \cdot \left( \frac{C}{W} \cdot \frac{1}{f_i} \right)^3$$

- $L_{km}$  = calculated service life (km)
- $C$  = dynamic load capacity (N) =  $C_{Orad}$
- $W$  = equivalent load (N)
- $f_i$  = application coefficient (see tab. 17)

Fig. 19

### Series SNK

$$L_{km} = 100 \cdot \left( \frac{C}{W} \cdot \frac{f_c}{f_i} \cdot f_h \right)^3$$

- $L_{km}$  = theoretical service life (km)
- $C$  = dynamic load capacity (N) =  $C_{Orad}$
- $W$  = effective equivalent load (N)
- $f_c$  = contact factor
- $f_i$  = application coefficient
- $f_h$  = stroke factor

Fig. 20

The stroke factor  $f_h$  takes into account the higher load of the raceways and rollers during short strokes on the same total length of run. The corresponding values are taken from the following graph (for strokes longer than 1 m,  $f_h = 1$ ):

Number of sliders	1	2	3	4
$f_c$	1	0.8	0.7	0.63

Tab. 16

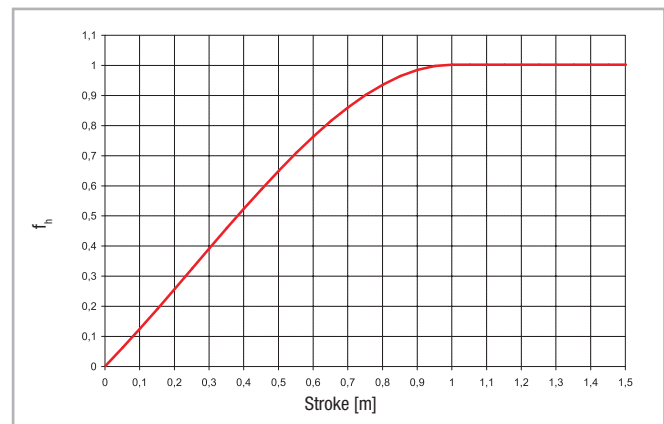

Fig. 21

### Application coefficient $f_i$

Neither impacts nor vibrations, smooth and low-frequency direction change, clean operating conditions, low speed (<0.5 m/s)	1 - 1.5
Slight vibrations, average speeds (between 0.5 and 0.7 m/s) and average direction change	1.5 - 2
Impacts and vibrations, high-frequency direction change, high speeds (>0.7 m/s), very dirty environment	2 - 3.5

Tab. 17

If the external load,  $P$ , is the same as the dynamic load capacity,  $C_{Orad}$ , (which must never be exceeded), the service life at ideal operating conditions ( $f_i = 1$ ) amounts to 100 km. Naturally, for a single load  $P$ , the following applies:  $W = P$ . If several external loads occur simultaneously, the equivalent load is calculated as follows:

$$W = P_{rad} + \left( \frac{P_{ax}}{C_{Oax}} + \frac{M_1}{M_x} + \frac{M_2}{M_y} + \frac{M_3}{M_z} \right) \cdot C_{Orad}$$

Fig. 22

## > Clearance and preload

The linear ball bearings of the SN and SNK series are mounted as standard with no play. For more information, please contact Rollon technical support.

Preload classes		
Increased clearance	No clearance	Increased preload
G <sub>1</sub>	Standard	K <sub>1</sub>

Tab. 18

\* for higher preload, contact Rollon technical support.

## > Coefficient of friction

With correct lubrication and installation on level and rigid surfaces and sufficient parallelism for rail pairs, the friction value is less than or equal to 0.01. This value can vary depending on the installation situation (see pg. ES-19, Instructions for use). For the SNK series, the coefficient of friction is equal to or less than 0.06.

## > Linear accuracy

With installation of the rails using all bolts on a perfectly plane support surface with the fixing holes in a straight line, the linear accuracy of the sliders to an external reference results from the following equation:

$\square // = \frac{\sqrt{H}}{300} \text{ (mm)}$	H = Stroke
--	------------

Fig. 23

## > Speed

The linear bearings of the SN series can be used up to an operating speed of 0.8 m/s (31.5 in/s). With high-frequency direction changes and the resulting high accelerations, as well as with long ball cages, there is a risk of cage creep (see pg. ES-19, Instructions for use). The SNK series rails, on the other hand, reach a maximum speed of 1.5 m/s, and there is no risk of cage creep.

## > Temperature

The SN series can be used in ambient temperatures from -30 °C to +170 °C (-22 °F to +338 °F). The SNK series can be used at ambient temperatures between -20 °C and + 70 °C. A lithium lubricant for high operating temperatures is recommended for temperatures above +130 °C (+266 °F).

E  
S

### > Anticorrosive protection

- The SN series standard anticorrosive protection is electrolytic zinc plating in accordance with ISO 2081. If increased anticorrosive protection is required, chemically nickel plated rails and stainless steel ball bearings are available.
- Numerous application-specific surface treatments are available upon request, e.g., FDA-approved nickel plating for use in the food industry. For more information, please contact Rollon technical support.

### > Lubrication SN

Recommended lubrication intervals are heavily dependent upon the ambient conditions. Under normal conditions, lubrication is recommended after 100 km operational performance or after an operating period of 6 months. In critical application cases the interval should be shorter. Please clean the raceways carefully before lubrication. Raceways and spaces of the ball cage are lubricated with a lithium lubricant of average consistency (roller bearing lubricant).

Different lubricants are available on request for special applications:

- FDA-approved lubricant for use in the food industry
- specific lubricant for clean rooms

- specific lubricant for the marine technology sector
  - specific lubricant for high and low temperatures
- For specific information, contact Rollon technical support.

Under normal conditions, correct lubrication:

- reduces friction
- reduces wear
- reduces stress on contact surfaces due to elastic deformation
- reduces noise during operation
- increases the regularity of the rolling movement

### > Lubrication SNK

#### Lubrication when using N-sliders SNK43

The SNK43 sliders are fitted with a self lubricating kit provided to periodically lubricate the slider.

This provides a progressive release of lubricant (see tab. 36) on the raceway during operation of the slider. The expected service life is up to 2 million cycles, depending on the type of application. The zerk fittings (see fig. 24) provide the lubrication.

Different lubricants are available on request for special applications:

- FDA-approved lubricant for use in the food industry
- specific lubricant for clean rooms
- specific lubricant for the marine technology sector
- specific lubricant for high and low temperatures

For specific information, contact Rollon technical support.

Lubricant	Thickening agent	Temperature range [°C]	Dynamic viscosity [mPas]
Mineral oil	Lithium soap	-30... to +120	< 1000
Roller bearing lubricant	Lithium soap	-30 to +170	4500

Tab. 19

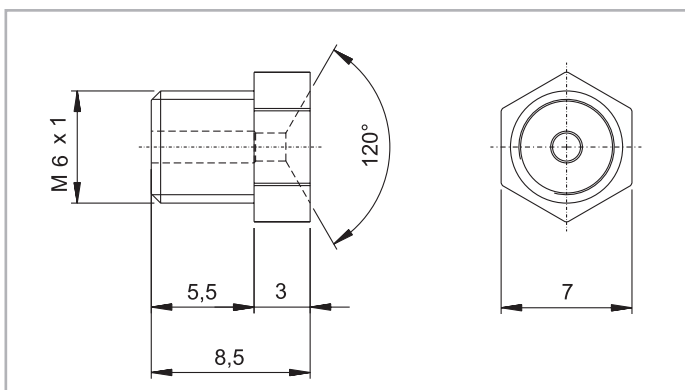

Grease applicator M6x1 DIN 3405 compliant

Fig. 24

## > Fixing screws

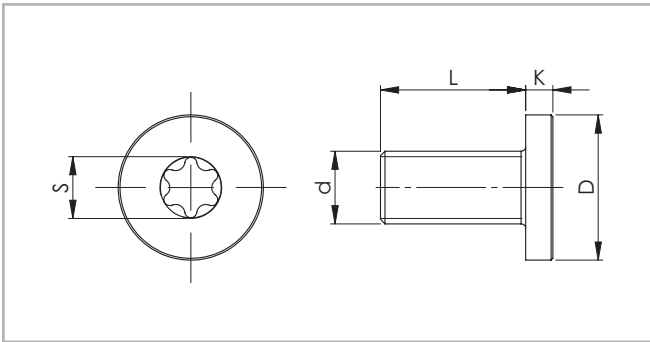

Fig. 25

The rails of the SN series in sizes 22 to 43 mm are fixed with countersunk head screws according to DIN 7991.

The SNK43 series rails are fastened with countersunk head screws according to DIN 7991 or with TorxR head screws (special design, see fig. 25).

Size	Screw type	d	D [mm]	L [mm]	K [mm]	S	Tightening torque
63	M8 x 20	M8 x 1.25	13	20	5	T40	34,7
SNK43	M8 x 16	M8 x 1,25	16	16	3	T40	22

Tab. 20

### Recommended Standard fixing screw tightening torques

Property class	Size	Tightening torque [Nm]
10.9	22	3
	28	6
	35	10
	43	25
	63	30

Tab. 21

A support of the rail sides is not strictly necessary, but it helps reduce stress on the screws and increases rigidity.

### Rail Bracket

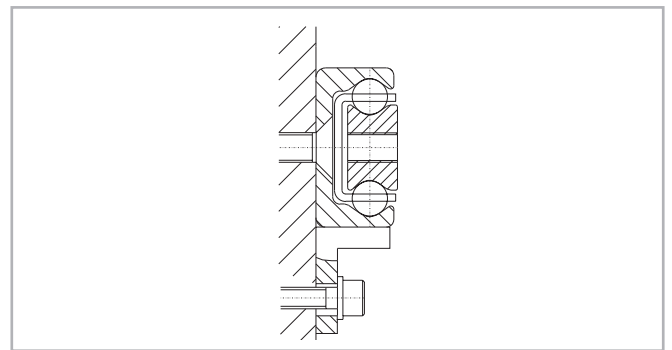

Fig. 26

A support is advisable if the safety coefficient of the application is equal to or lower than 1.5.

## > Installation instructions

- The internal stops on the SN series are used to stop the unloaded slider and the ball cage. Please use external stops as end stops for a loaded system.
- Prepare a sufficient bevel on the threaded fixing holes, according to the following table:
- To achieve optimum running properties, high service life and rigidity, it is necessary to fix the linear bearings with all accessible holes on a rigid and level surface.

Size	Bevel (mm)
22	0,5 x 45°
28	1 x 45°
35	1 x 45°
43	1 x 45°
63	1 x 45°

Tab. 22

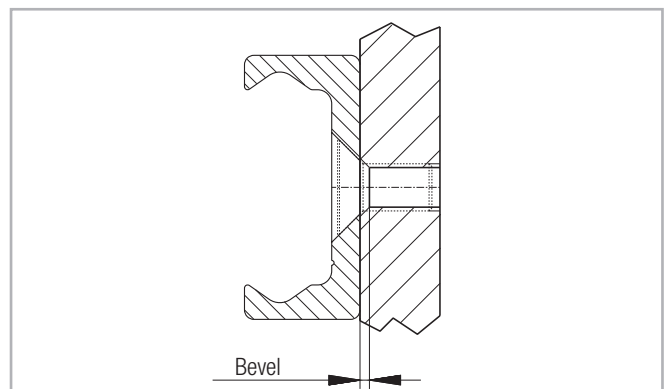

Fig. 27

### > SNK Joined Rails

If long guide rails are required, two or more rails can be joined to the desired length. When putting guide rails together, be sure that the register marks shown in fig. 28 are positioned correctly.

These are fabricated asymmetric for parallel application of joined guide rails, unless otherwise specified.

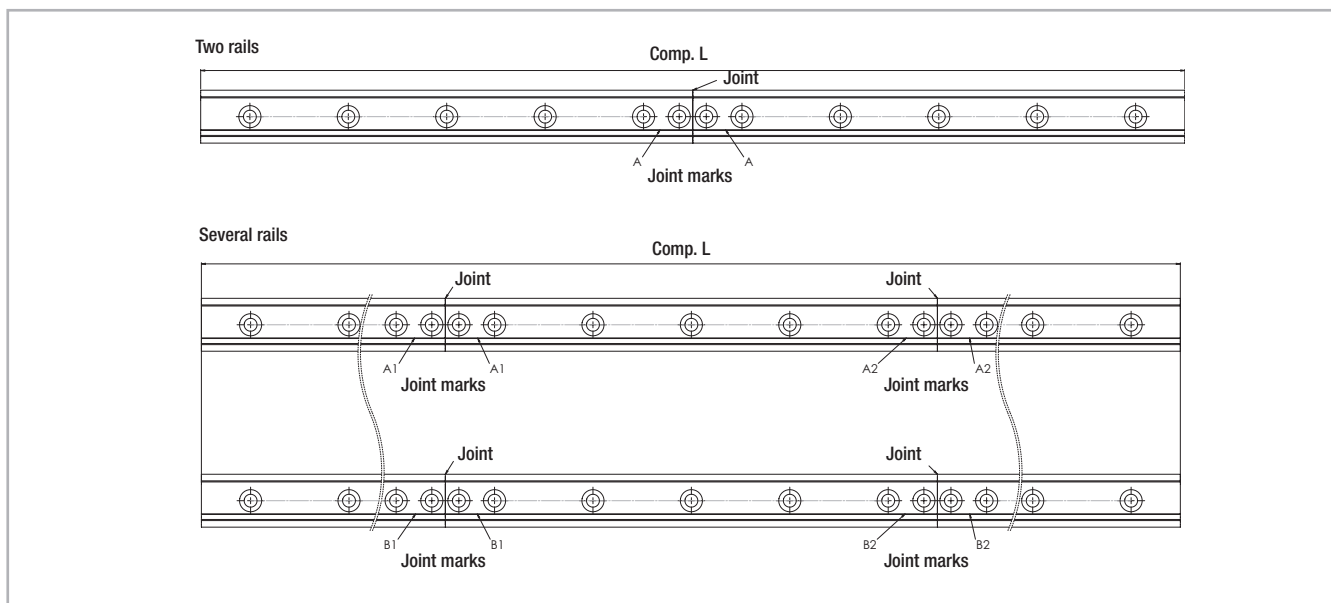

Fig. 28

#### General information

The maximum available rail length in one piece is indicated in table 13 on page ES-10. Longer lengths are achieved by joining two or more rails (joined rails).

Rollon machines the rail ends at a right angle to the impact surfaces and marks them. Additional fixing screws are included with the delivery, which ensure a problem-free transition of the slider over the joints, if the following installation procedures are followed. Two additional threaded holes are required in the load-bearing structure. The included end fixing screws correspond to the installation screws for the rails for cylindrical counterbores. The alignment fixture for aligning the rail joint can be ordered using the designation given in the table (tab. 23).

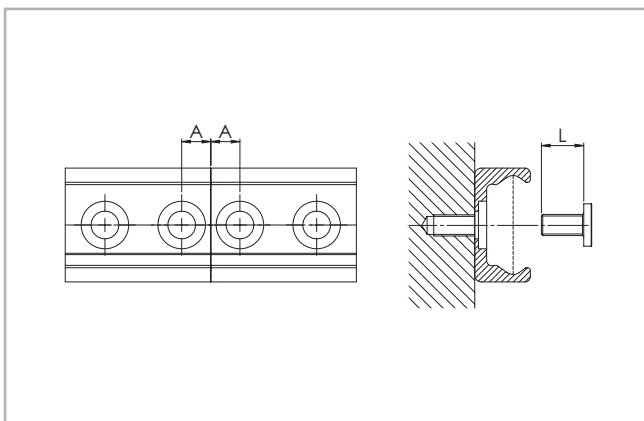

Fig. 29

Rail type	A [mm]	Threaded hole (load-bearing structure)	Screw type	L [mm]	Alignment fixture
TVC/TVS	11	M8	see pg. CR-31	16	AT43

Tab. 23

## > SN instructions for use

- For linear bearings of the SN series, the sliders are guided through a ball cage inside the rails. When the sliders run their course relative to the rails, the ball cage moves along for half the slider stroke. The stroke ends as soon as the slider reaches the end of the cage.  
Normally the cage moves synchronously to the balls at half the speed of the slider. Any occurring cage slip affects the synchronous movement of the ball cage negatively, causing it to reach the internal stops prematurely (cage creep). This reduces the stroke. However, the stroke value can be normalized at any time by moving the slider to the stop in the stopped cage. This moving of the slider relative to the cage will have increased resistance, which is dependent on the working load.
- The causes of cage creep can be installation accuracy, dynamics, and load changes. The effects can be minimized by observing the following advice:
  - The stroke should always remain constant and come as close as possible to the nominal stroke of the linear bearing.
  - For applications with various strokes, make sure that the drive is sufficiently dimensioned to guarantee a movement of the slider relative to the cage. A coefficient of friction of 0.1 should be calculated for this.
  - Another possibility is to include a maximum stroke without load in the working cycle in order to resynchronize the slider and ball cage.  
Parallelism errors or inaccuracies in the installation or in the mounting surfaces of mounted pairs can influence the cage creep.
- Series SN linear bearings should only be used for horizontal movement.

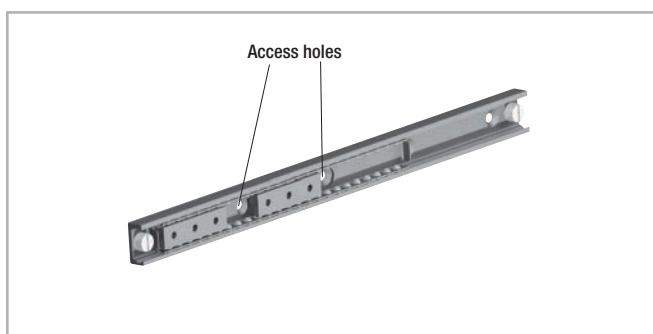

Fig. 30

If the bearing cage covers one or more fixing holes for the rail, access holes are made in the cage. The number and position of the holes can vary in different supplies.

Access to all fixing screws of the rail is guaranteed in all cases by positioning the cage aligned with the holes.

## SNK instructions for use

- SNK: Always handle the slider out of the rail by its plastic retainer to prevent ball bearings from escaping.

# SN Standard configurations



## Size 22

Ordering description	Slider	Stroke	Rail
SN22-40-60-130	40	60	130
SN22-40-140-210	40	140	210
SN22-40-220-290	40	220	290
SN22-60-40-130	60	40	130
SN22-60-120-210	60	120	210
SN22-60-200-290	60	200	290
SN22-60-280-370	60	280	370
SN22-60-360-450	60	360	450
SN22-80-100-210	80	100	210
SN22-80-180-290	80	180	290
SN22-80-260-370	80	260	370
SN22-80-340-450	80	340	450
SN22-80-420-530	80	420	530
SN22-80-500-610	80	500	610
SN22-130-130-290	130	130	290
SN22-130-210-370	130	210	370
SN22-130-290-450	130	290	450
SN22-130-370-530	130	370	530
SN22-130-450-610	130	450	610
SN22-130-530-690	130	530	690
SN22-130-610-770	130	610	770
SN22-130-690-850	130	690	850
SN22-130-770-930	130	770	930
SN22-130-850-1010	130	850	1010
SN22-210-210-450	210	210	450
SN22-210-290-530	210	290	530
SN22-210-370-610	210	370	610
SN22-210-450-690	210	450	690
SN22-210-530-770	210	530	770
SN22-210-610-850	210	610	850
SN22-210-690-930	210	690	930
SN22-210-770-1010	210	770	1010
SN22-210-930-1170	210	930	1170
SN22-290-290-610	290	290	610
SN22-290-370-690	290	370	690
SN22-290-450-770	290	450	770
SN22-290-530-850	290	530	850
SN22-290-610-930	290	610	930
SN22-290-690-1010	290	690	1010
SN22-290-850-1170	290	850	1170

Tab. 24

## Size 28

Ordering description	Slider	Stroke	Rail
SN28-60-30-130	60	30	130
SN28-60-110-210	60	110	210
SN28-60-190-290	60	190	290
SN28-60-270-370	60	270	370
SN28-60-350-450	60	350	450
SN28-80-90-210	80	90	210
SN28-80-170-290	80	170	290
SN28-80-250-370	80	250	370
SN28-80-330-450	80	330	450
SN28-80-410-530	80	410	530
SN28-80-490-610	80	490	610
SN28-130-120-290	130	120	290
SN28-130-200-370	130	200	370
SN28-130-280-450	130	280	450
SN28-130-360-530	130	360	530
SN28-130-440-610	130	440	610
SN28-130-520-690	130	520	690
SN28-130-600-770	130	600	770
SN28-130-680-850	130	680	850
SN28-130-760-930	130	760	930
SN28-130-840-1010	130	840	1010
SN28-210-200-450	210	200	450
SN28-210-280-530	210	280	530
SN28-210-360-610	210	360	610
SN28-210-440-690	210	440	690
SN28-210-520-770	210	520	770
SN28-210-600-850	210	600	850
SN28-210-680-930	210	680	930
SN28-210-760-1010	210	760	1010
SN28-210-920-1170	210	920	1170
SN28-210-1080-1330	210	1080	1330
SN28-290-280-610	290	280	610
SN28-290-360-690	290	360	690
SN28-290-440-770	290	440	770
SN28-290-520-850	290	520	850
SN28-290-600-930	290	600	930
SN28-290-680-1010	290	680	1010
SN28-290-840-1170	290	840	1170
SN28-290-1000-1330	290	1000	1330
SN28-290-1160-1490	290	1160	1490
SN28-370-360-770	370	360	770
SN28-370-440-850	370	440	850
SN28-370-520-930	370	520	930
SN28-370-600-1010	370	600	1010
SN28-370-760-1170	370	760	1170
SN28-370-920-1330	370	920	1330
SN28-370-1080-1490	370	1080	1490
SN28-450-440-930	450	440	930
SN28-450-520-1010	450	520	1010
SN28-450-680-1170	450	680	1170
SN28-450-840-1330	450	840	1330
SN28-450-1000-1490	450	1000	1490
SN28-450-1160-1650	450	1160	1650

Tab. 25

## Size 35

Ordering description	Slider	Stroke	Rail
SN35-130-110-290	130	110	290
SN35-130-190-370	130	190	370
SN35-130-270-450	130	270	450
SN35-130-350-530	130	350	530
SN35-130-430-610	130	430	610
SN35-130-510-690	130	510	690
SN35-130-590-770	130	590	770
SN35-130-670-850	130	670	850
SN35-130-750-930	130	750	930
SN35-130-830-1010	130	830	1010
SN35-210-190-450	210	190	450
SN35-210-270-530	210	270	530
SN35-210-350-610	210	350	610
SN35-210-430-690	210	430	690
SN35-210-510-770	210	510	770
SN35-210-590-850	210	590	850
SN35-210-670-930	210	670	930
SN35-210-750-1010	210	750	1010
SN35-210-910-1170	210	910	1170
SN35-210-1070-1330	210	1070	1330
SN35-210-1230-1490	210	1230	1490
SN35-290-270-610	290	270	610
SN35-290-350-690	290	350	690
SN35-290-430-770	290	430	770
SN35-290-510-850	290	510	850
SN35-290-590-930	290	590	930
SN35-290-670-1010	290	670	1010
SN35-290-830-1170	290	830	1170
SN35-290-990-1330	290	990	1330
SN35-290-1150-1490	290	1150	1490
SN35-290-1310-1650	290	1310	1650
SN35-370-350-770	370	350	770
SN35-370-430-850	370	430	850
SN35-370-510-930	370	510	930
SN35-370-590-1010	370	590	1010
SN35-370-750-1170	370	750	1170
SN35-370-910-1330	370	910	1330
SN35-370-1070-1490	370	1070	1490
SN35-370-1230-1650	370	1230	1650
SN35-450-430-930	450	430	930
SN35-450-510-1010	450	510	1010
SN35-450-670-1170	450	670	1170
SN35-450-830-1330	450	830	1330
SN35-450-990-1490	450	990	1490
SN35-450-1150-1650	450	1150	1650
SN35-450-1310-1810	450	1310	1810
SN35-530-590-1170	530	590	1170
SN35-530-750-1330	530	750	1330
SN35-530-910-1490	530	910	1490
SN35-530-1070-1650	530	1070	1650
SN35-530-1230-1810	530	1230	1810
SN35-610-670-1330	610	670	1330
SN35-610-830-1490	610	830	1490
SN35-610-990-1650	610	990	1650
SN35-610-1150-1810	610	1150	1810

Tab. 26



Size 43

Ordering description	Slider	Stroke	Rail
SN43-130-110-290	130	110	290
SN43-130-190-370	130	190	370
SN43-130-270-450	130	270	450
SN43-130-350-530	130	350	530
SN43-130-430-610	130	430	610
SN43-130-510-690	130	510	690
SN43-130-590-770	130	590	770
SN43-130-670-850	130	670	850
SN43-130-750-930	130	750	930
SN43-130-830-1010	130	830	1010
SN43-210-190-450	210	190	450
SN43-210-270-530	210	270	530
SN43-210-350-610	210	350	610
SN43-210-430-690	210	430	690
SN43-210-510-770	210	510	770
SN43-210-590-850	210	590	850
SN43-210-670-930	210	670	930
SN43-210-750-1010	210	750	1010
SN43-210-910-1170	210	910	1170
SN43-210-1070-1330	210	1070	1330
SN43-210-1230-1490	210	1230	1490
SN43-210-1390-1650	210	1390	1650
SN43-290-270-610	290	270	610
SN43-290-350-690	290	350	690
SN43-290-430-770	290	430	770
SN43-290-510-850	290	510	850
SN43-290-590-930	290	590	930
SN43-290-670-1010	290	670	1010
SN43-290-830-1170	290	830	1170
SN43-290-990-1330	290	990	1330
SN43-290-1150-1490	290	1150	1490
SN43-290-1310-1650	290	1310	1650
SN43-290-1470-1810	290	1470	1810
SN43-370-350-770	370	350	770
SN43-370-430-850	370	430	850
SN43-370-510-930	370	510	930
SN43-370-590-1010	370	590	1010
SN43-370-750-1170	370	750	1170
SN43-370-910-1330	370	910	1330
SN43-370-1070-1490	370	1070	1490
SN43-370-1230-1650	370	1230	1650
SN43-370-1390-1810	370	1390	1810
SN43-450-430-930	450	430	930
SN43-450-510-1010	450	510	1010
SN43-450-670-1170	450	670	1170
SN43-450-830-1330	450	830	1330
SN43-450-990-1490	450	990	1490
SN43-450-1150-1650	450	1150	1650
SN43-450-1310-1810	450	1310	1810
SN43-450-1470-1970	450	1470	1970
SN43-530-590-1170	530	590	1170
SN43-530-750-1330	530	750	1330
SN43-530-910-1490	530	910	1490
SN43-530-1070-1650	530	1070	1650
SN43-530-1230-1810	530	1230	1810
SN43-530-1390-1970	530	1390	1970
SN43-610-670-1330	610	670	1330
SN43-610-830-1490	610	830	1490
SN43-610-990-1650	610	990	1650
SN43-610-1150-1810	610	1150	1810
SN43-610-1310-1970	610	1310	1970

Tab. 27

Size 63

Ordering description	Slider	Stroke	Rail
SN63-130-400-610	130	400	610
SN63-130-480-690	130	480	690
SN63-130-560-770	130	560	770
SN63-130-640-850	130	640	850
SN63-130-720-930	130	720	930
SN63-130-800-1010	130	800	1010
SN63-210-320-610	210	320	610
SN63-210-400-690	210	400	690
SN63-210-480-770	210	480	770
SN63-210-560-850	210	560	850
SN63-210-640-930	210	640	930
SN63-210-720-1010	210	720	1010
SN63-210-880-1170	210	880	1170
SN63-210-1040-1330	210	1040	1330
SN63-210-1200-1490	210	1200	1490
SN63-210-1360-1650	210	1360	1650
SN63-290-240-610	290	240	610
SN63-290-320-690	290	320	690
SN63-290-400-770	290	400	770
SN63-290-480-850	290	480	850
SN63-290-560-930	290	560	930
SN63-290-640-1010	290	640	1010
SN63-290-800-1170	290	800	1170
SN63-290-960-1330	290	960	1330
SN63-290-1120-1490	290	1120	1490
SN63-290-1280-1650	290	1280	1650
SN63-370-320-770	370	320	770
SN63-370-400-850	370	400	850
SN63-370-480-930	370	480	930
SN63-370-560-1010	370	560	1010
SN63-370-720-1170	370	720	1170
SN63-370-880-1330	370	880	1330
SN63-370-1040-1490	370	1040	1490
SN63-370-1200-1650	370	1200	1650
SN63-370-1360-1810	370	1360	1810
SN63-450-400-930	450	400	930
SN63-450-480-1010	450	480	1010
SN63-450-640-1170	450	640	1170
SN63-450-800-1330	450	800	1330
SN63-450-960-1490	450	960	1490
SN63-450-1120-1650	450	1120	1650
SN63-450-1280-1810	450	1280	1810
SN63-530-560-1170	530	560	1170
SN63-530-720-1330	530	720	1330
SN63-530-880-1490	530	880	1490
SN63-530-1040-1650	530	1040	1650
SN63-530-1200-1810	530	1200	1810
SN63-530-1360-1970	530	1360	1970
SN63-610-640-1330	610	640	1330
SN63-610-800-1490	610	800	1490
SN63-610-960-1650	610	960	1650
SN63-610-1120-1810	610	1120	1810
SN63-610-1280-1970	610	1280	1970

Tab. 28

The most commonly used standard configurations are shown in the tables. Other deviating configurations and customer-specific adaptations are possible. For more information, please contact Rollon Technical Support.

# Ordering key



## > SN Version 1 with a slider

<b>SN</b>	<b>35</b>	<b>290</b>	<b>430</b>	<b>770</b>	<b>K1</b>	<b>NIC</b>	
							Expanded surface protection <i>see pg. ES-16, Anticorrosive protection</i>
							Clearance and preload, if deviating from standard <i>see pg. ES-15, tab. 18</i>
							Rail length <i>see pg. ES-5, tab. 2, 4, 6, 8, 10</i>
							Stroke <i>see pg. ES-5, fig. 7, tab. 1 to 10</i>
							Slider length <i>see pg. ES-5, tab. 1, 3, 5, 7, 9</i>
							Size <i>see pg. ES-5, Performance characteristics</i>
							Product type

Ordering example 1: SN35-0290-0430-0770

Ordering example 2: SN35-0290-0430-0770-K1-NIC

Notes on ordering: Rail and slider lengths, as well as strokes, are always stated with 4 digits. Please use zeroes to fill in for lengths with less than 4 digits

## > SN version 2 with multiple independent sliders

<b>SN</b>	<b>43</b>	<b>2</b>	<b>290</b>	<b>350</b>	<b>1330</b>	<b>G1</b>	<b>NIC</b>	
								Expanded surface protection <i>see pg. ES-16, Anticorrosive protection</i>
								Clearance and preload, if deviating from standard <i>see pg. ES-15, tab. 18</i>
								Rail length <i>see pg. ES-5, tab. 2, 4, 6, 8, 10</i>
								Stroke of the individual sliders <i>see pg. ES-5, fig. 7, tab. 1 to 10</i>
								Slider length <i>see pg. ES-5, tab. 1, 3, 5, 7, 9</i>
								Number of sliders
								Size <i>see pg. ES-5, Performance characteristics</i>
								Product type

Ordering example 1: SN43-2x0290-0350-1330

Ordering example 2: SN43-2x0290-0350-1330-G1-NIC

If the individual slider lengths and/or strokes are different, please order according to ordering example 3.

Ordering example 3: SN28-1x0200-0300/1x0250-0415-1240

Notes on ordering: Rail and slider lengths, as well as strokes, are always stated with 4 digits. Please use zeroes to fill in for lengths with less than 4 digits

> SN Version 3 with multiple synchronized sliders

SN	63	850	(370+290)	400	1330	K1	NIC
							Expanded surface protection <i>see pg. ES-16, Anticorrosive protection</i>
							Clearance and preload, if deviating from standard <i>see pg. ES-15, tab. 18</i>
					Rail length		<i>see pg. ES-5, tab. 2, 4, 6, 8, 10</i>
				Stroke			<i>see pg. ES-5, fig. 7, tab. 1 to 10</i>
			Individual length of slider				<i>see pg. ES-5, tab. 1, 3, 5, 7, 9</i>
			Apparent length, S' of the slider				<i>see pg. ES-8, fig. 9</i>
	Size	<i>see pg. ES-5 Performance characteristics</i>					
Product type							

Ordering example 1: SN63-0850(370+290)-0400-1330

Ordering example 2: SN63-0850(370+290)-0400-1330-K1-NI C

Notes on ordering: Rail and slider lengths, as well as strokes, are always stated with 4 digits. Please use zeroes to fill in for lengths with less than 4 digits

> Serie SNK

SNK	43	1	110	2320	TSC	NIC
						For surface protection different from standard ISO 2081 <i>see pg. ES-16</i>
					Tipo di guida	<i>see pg. ES-10 e ES-11</i>
				Rail length		<i>see pg. ES-10 tab 13</i>
			Slider length			<i>see pg. ES-10.</i>
			Number of sliders for each rail			
	Size	<i>see pg. ES-5 Performance characteristics</i>				
Product type						

Ordering example: SNK43-1x110-02320-TSC-NIC

Rail kit: 1x2000+1x320 (only for joined rails)

Drilling pattern: 40-40x80-40//40-15x80-40 (always state the drilling pattern separately)

Note for ordering: Rail lengths are always shown with five figures, and slider lengths are indicated with three figures preceded by zeros

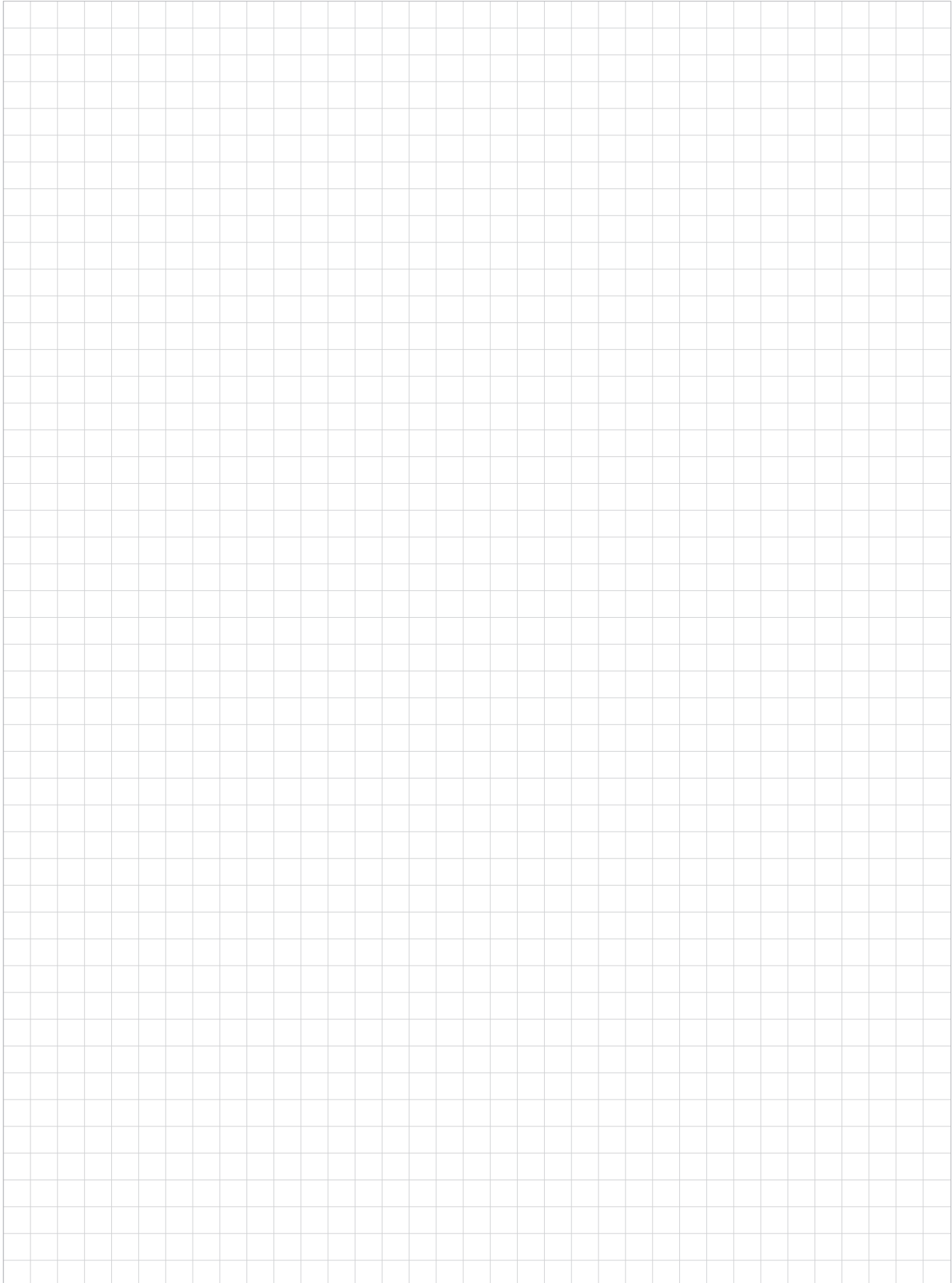

**ROLLON**<sup>®</sup>  
Linear Evolution

**Mono Rail +**

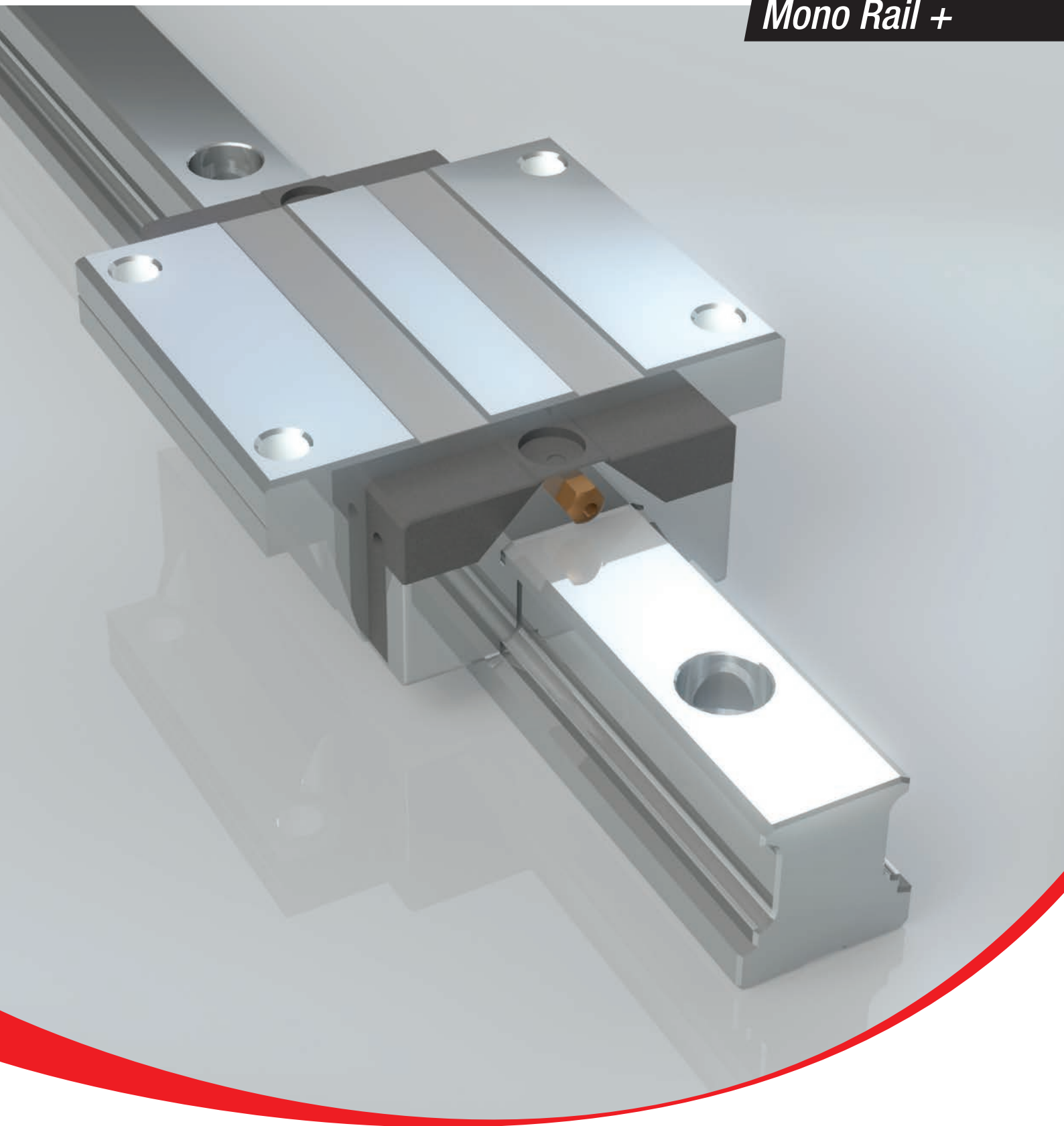



## Product explanation



### > Mono Rail Plus is the profile rail for the highest degree of precision



Fig. 1

The running grooves are ground in a semicircular profile and have a contact angle of 45° in 0 arrangement to ensure the same load capacity in all principle directions. The use of large steel balls enables high load and moment capacities.

#### The most important characteristics:

- 0 arrangement with 2-point contact of the raceways
- Uniform load capacity in all main directions
- High ability for self-regulating
- Small differential slip in comparison to 4-point contact
- Very quiet running and low operating noise
- Low displacement force in preload compared to 4-point contact
- Mono Rail Plus profile rails conform to the market standard and can replace linear rails of the same design from other manufacturers while maintaining the main dimensions

#### Preferred areas of application:

- Construction and machine technology (safety doors, feeding)
- Packaging machines
- Special purpose machinery
- Logistics (e.g. handling units)
- Medical technology (e.g. X-ray machines, hospital gurneys)

Produced in partnership with CPC

**MRSO / MRTO**



Standard carriage with flange in two different heights. MRTO is the lower version.

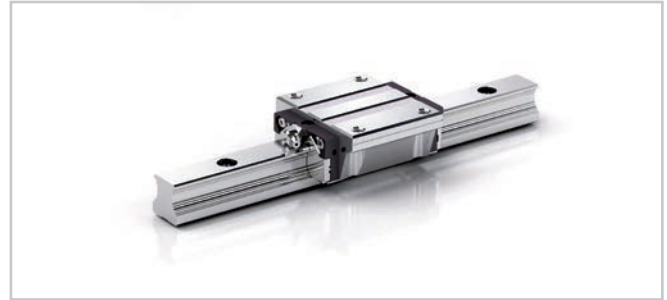

Fig. 2

**MRSO...W / MRZO...W / MRTO...W**



Carriage without flange, also called block. Available in three different heights. MRTO is the lower version; MRZO is the intermediate size.

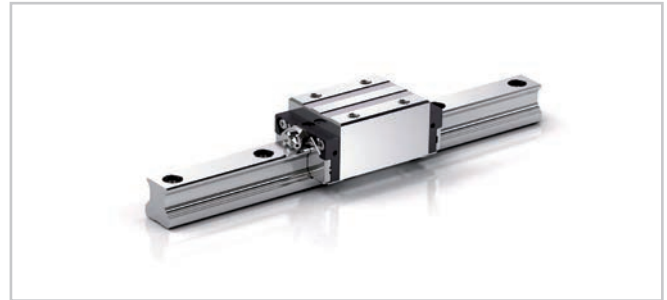

Fig. 3

**MRSO...L**



Carriage in long version for holding larger loads. MRSO...L is the version with flange; MRSO...LW is the version without flange.



Fig. 4

**MRSO...LW / MRTO...LW**



Carriage in long version without flange. Available in two different heights. MRTO is the lower version.

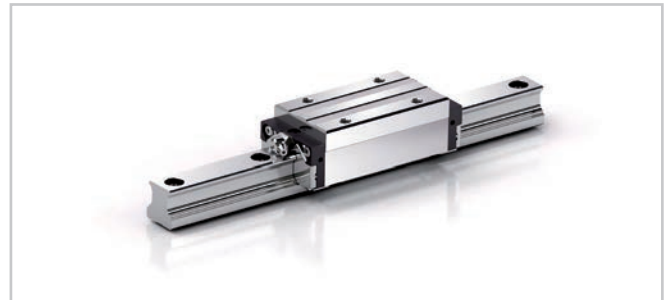

Fig. 5



**MRTO...S**

Carriage in short version with flange for small loads with equally high precision.

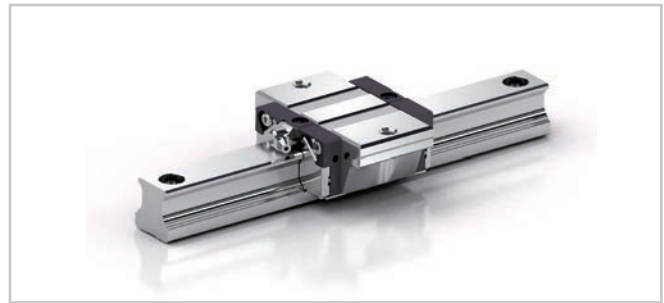

Fig. 6

**MRTO...SW**

Carriage in short version without flange for small loads with equally high precision.

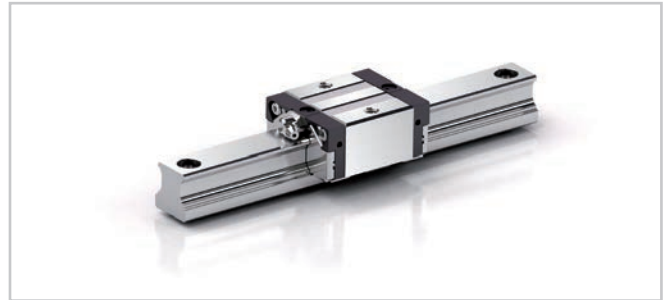

Fig. 7

**MRRO...F**

All sizes are also available in a version with rail mounting from below. The smooth rail surface is an advantage in extremely dirty environments. Please contact our application engineers for further information.

## Technical data

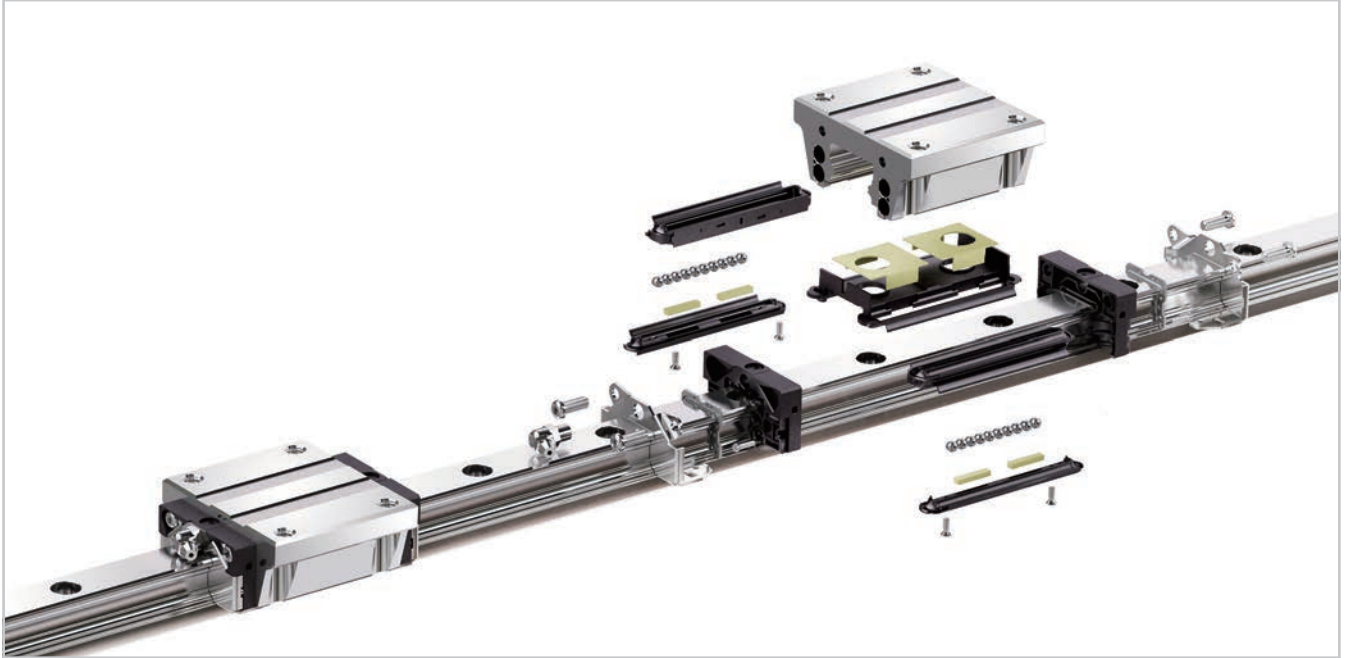

Fig. 8

### Performance characteristics:

- Available sizes: 15, 20, 25, 30, 35, 45
- Max. operating speed: 5 m/s (196.9 in/s)  
(depending on application)
- Max. operating temperature: +80 °C (+176 °F)  
(depending on application)
- Available rail lengths up to about 4,000 mm (157.5 in)
- Four preload classes: VC, V0, V1, V2
- Three precision classes: N, H, P

### Stainless steel reinforcement plate

The two reinforcement plates can be mounted at two positions on the carriage. This increases stability between the end cap and the carriage and allows high sliding speeds and acceleration. The plates, with a maximum gap of 0.3 mm to the rail, function as a deflector for larger foreign objects.

### Inner and side seals

The carriages are equipped with end seals to keep out dust as standard equipment. In addition, most of the carriages feature inner and side seals to prevent foreign objects from entering the row of balls.

### Remarks:

- Combining of rails is possible (joint processed rails)
- The mounting holes on the carriages with flange can also be used as through holes for mounting from below. In this case, the reduction in the size of the screw diameter must be taken into account
- Various surface coatings available on request
- Manual and pneumatic clamping accessories available on request
- Primary lubricated systems have increased sliding resistance

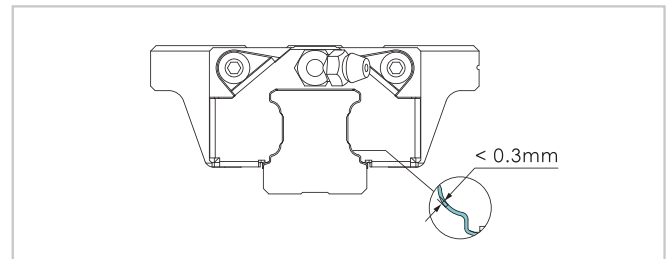

Fig. 9

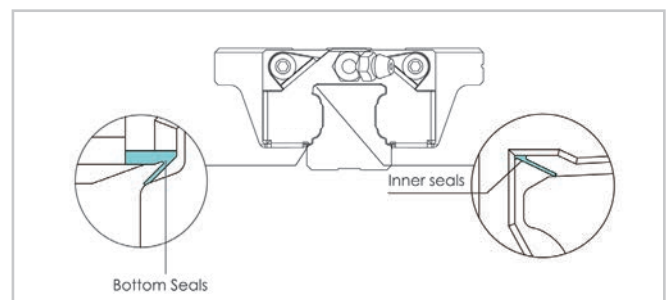

Fig. 10

# Load Capacities

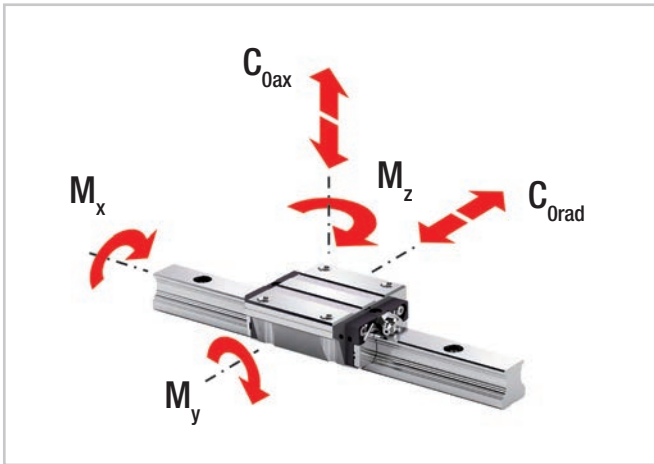

Fig. 11

Type	Load capacities [kN]		Static moments [Nm]		
	dyn. C	stat. C <sub>0rad</sub> stat. C <sub>0ax</sub>	M <sub>x</sub>	M <sub>y</sub>	M <sub>z</sub>
MRSO15 MRSO15W MRTO15 MRTO15W	9.9	17.5	140	105	105
MRTO15S MRTO15SW	7.7	12.1	100	50	50
MRSO20 MRSO20W MRTO20 MRTO20W	17.1	30	325	230	230
MRTO20S MRTO20SW	12.5	19.3	205	100	100
MRSO20L MRSO20LW	20.4	38.5	415	390	390
MRSO25 MRTO25 MRSO25W MRTO25W MRZO25W	24.8	42.5	540	385	385
MRTO25S MRTO25SW	18.2	27.3	350	160	160
MRSO25L MRSO25LW MRZO25LW	30.7	57.7	735	710	710

Tab. 1

Type	Load capacities [kN]		Static moments [Nm]		
	dyn. C	stat. C <sub>0rad</sub> stat. C <sub>0ax</sub>	M <sub>x</sub>	M <sub>y</sub>	M <sub>z</sub>
MRSO30 MRSO30W MRTO30 MRTO30W	32.8	53.7	845	565	565
MRTO30S MRTO30SW	23.3	33.1	520	230	230
MRSO30L MRSO30LW MRTO30LW	39.6	70.2	1105	950	950
MRSO35 MRSO35W MRTO35 MRTO35W	45.9	82.9	1700	1080	1080
MRSO35L MRSO35LW MRTO35LW	54.7	106.5	2185	1755	1755
MRSO45 MRSO45W MRTO45W	71.3	122.1	3200	1910	1910
MRSO45L MRSO45LW MRTO45LW	89.5	169.1	4430	3460	3460

Tab. 2

M  
R  
+

Product dimensions



Series MRSO / MRSO...L – carriage with flange

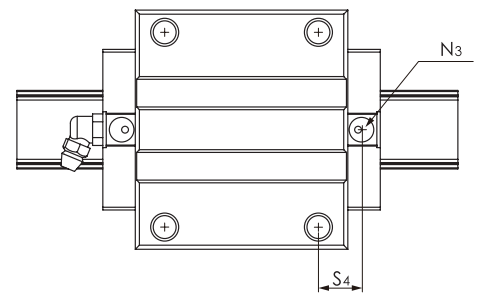
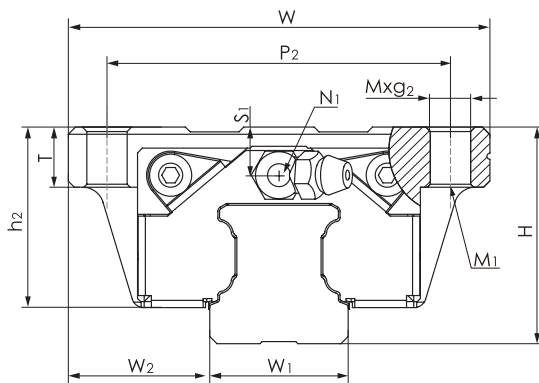

Type	System [mm]		Rail [mm]								
	H	W <sub>2</sub>	W <sub>1</sub>	H <sub>1</sub>	P	D x d x g <sub>1</sub>	W	L	L <sub>1</sub>	h <sub>2</sub>	P <sub>1</sub>
MRS015	24	16	15	15	60	7.5 x 4.5 x 5.3	47	55.5	40.3	20.7	30
MRS020	30	21.5	20	20	60	9.5 x 6 x 8.5	63	69	52	25	40
MRS020L	30	21.5	20	20	60	9.5 x 6 x 8.5	63	87.2	70.2	25	40
MRS025	36	23.5	23	23	60	11 x 7 x 9	70	81.2	62.2	30	45
MRS025L	36	23.5	23	23	60	11 x 7 x 9	70	105	86	30	45
MRS030	42	31	28	27	80	14 x 9 x 12	90	95.5	71.5	35.2	52
MRS030L	42	31	28	27	80	14 x 9 x 12	90	118	94	35.2	52
MRS035	48	33	34	32	80	14 x 9 x 12	100	111.2	86.2	40.4	62
MRS035L	48	33	34	32	80	14 x 9 x 12	100	136.6	111.6	40.4	62
MRS045	60	37.5	45	39	105	20 x 14 x 17	120	135.5	102.5	50.7	80
MRS045L	60	37.5	45	39	105	20 x 14 x 17	120	171.5	138.5	50.7	80

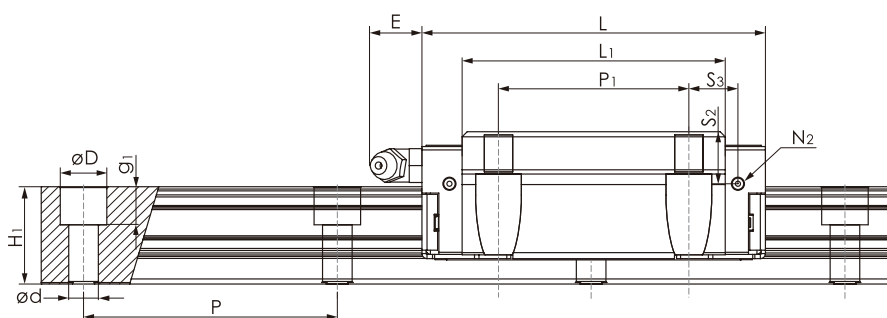
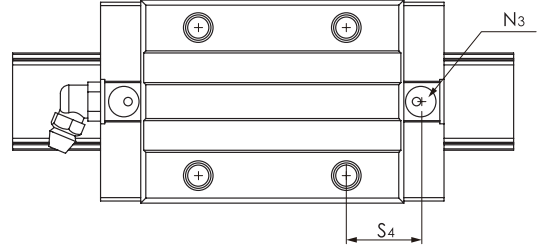
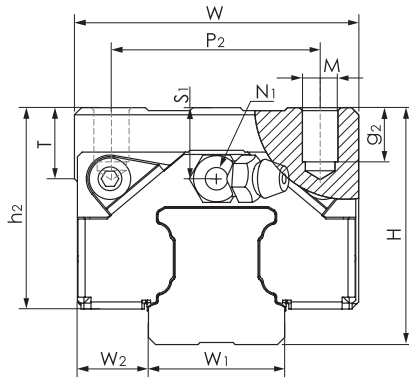

Fig. 12

Slider [mm]												Weight	
$P_2$	$M \times g_2$	$M_1$	T	$N_1$	$N_2$	$N_3$	E	$S_1$	$S_2$	$S_3$	$S_4$	Slider [kg]	Rail [kg/m]
38	M5 x 7	M4	7	M3 x 6.5	M3 x 6	P3	3.5	4.5	7.5	7.8	8.9	0.17	1.29
53	M6 x 10	M5	10	M3 x 7.5	M3 x 5.5	P4	10	6	9.4	9	9.7	0.40	2.28
53	M6 x 10	M5	9	M3 x 7.5	M3 x 5.5	P4	10	6	9.4	18.1	18.8	0.50	2.28
57	M8 x 12	M6	12	M6 x 7.5	M3 x 6.5	P4	12	8	12.3	11.6	12.6	0.63	3.02
57	M8 x 12	M6	12	M6 x 7.5	M3 x 6.5	P4	12	8	12.3	23.5	24.5	0.61	3.02
72	M10 x 15	M8	16	M6 x 8.5	M6 x 5	P5	12	7.5	12	14.8	14.5	1.11	4.38
72	M10 x 15	M8	16	M6 x 8.5	M6 x 5	P5	12	7.5	12	25.7	25.8	1.39	4.38
82	M10 x 15	M8	16	M6 x 10	M6 x 7	P5	12	8	15	17.4	18.1	1.55	6.79
82	M10 x 15	M8	16	M6 x 10	M6 x 7	P5	12	8	15	30.1	30.8	2	6.79
100	M12 x 18	M10	19	PT1/8 x 12.5	M6 x 10.5	P5	14	11.1	18.1	17.3	17.3	2.75	10.53
100	M12 x 18	M10	19	PT1/8 x 12.5	M6 x 10.5	P5	14	11.1	18.1	35	35	4.28	10.53

Tab. 3

Series MRS0...W / MRS0...LW – carriage without flange



Type	System [mm]		Rail [mm]								
	H	W <sub>2</sub>	W <sub>1</sub>	H <sub>1</sub>	P	D x d x g <sub>1</sub>	W	L	L <sub>1</sub>	h <sub>2</sub>	P <sub>1</sub>
MRS015W	28	9.5	15	15	60	7.5 x 4.5 x 5.3	34	55.5	40.3	24.7	26
MRS020W	30	12	20	20	60	9.5 x 6 x 8.5	44	69	52	25	36
MRS020LW	30	12	20	20	60	9.5 x 6 x 8.5	44	87.2	70.2	25	50
MRS025W	40	12.5	23	23	60	11 x 7 x 9	48	81.2	62.2	34	35
MRS025LW	40	12.5	23	23	60	11 x 7 x 9	48	105	86	34	50
MRS030W	45	16	28	27	80	14 x 9 x 12	60	95.5	71.5	38.4	40
MRS030LW	45	16	28	27	80	14 x 9 x 12	60	118	94	38.4	60
MRS035W	55	18	34	32	80	14 x 9 x 12	70	111.2	86.2	47.4	50
MRS035LW	55	18	34	32	80	14 x 9 x 12	70	136.6	111.6	47.4	72
MRS045W	70	20.5	45	39	105	20 x 14 x 17	86	135.5	102.5	60.7	60
MRS045LW	70	20.5	45	39	105	20 x 14 x 17	86	171.5	138.5	60.7	80

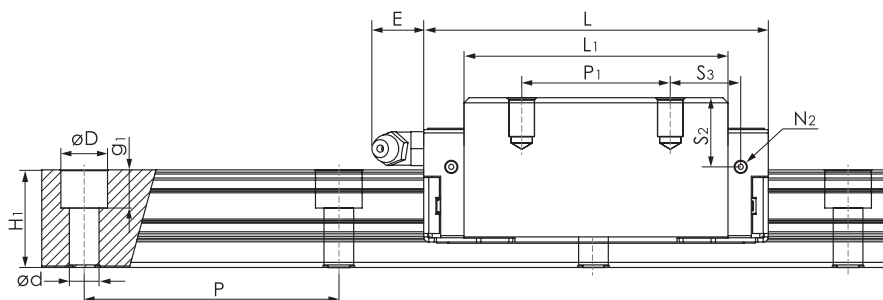
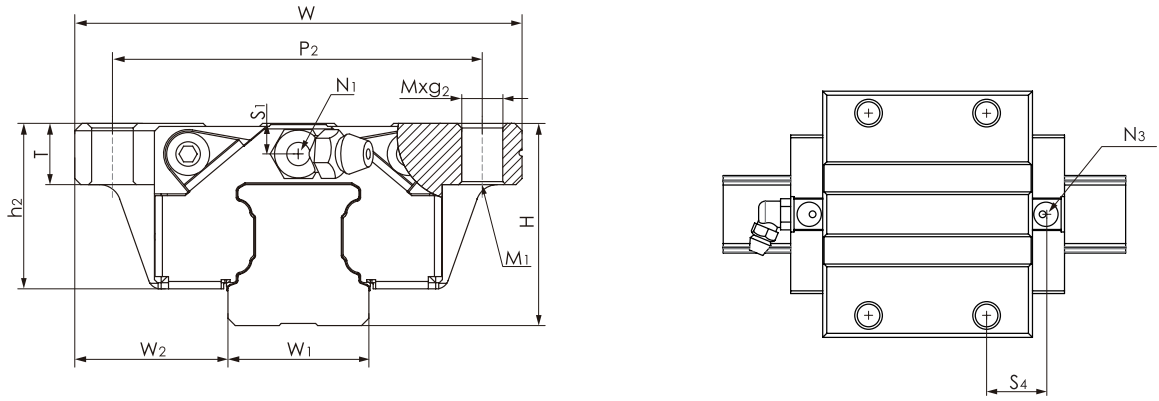

Fig. 13

Slider [mm]												Weight	
P <sub>2</sub>	M x g <sub>2</sub>	M <sub>1</sub>	T	N <sub>1</sub>	N <sub>2</sub>	N <sub>3</sub>	E	S <sub>1</sub>	S <sub>2</sub>	S <sub>3</sub>	S <sub>4</sub>	Slider [kg]	Rail [kg/m]
26	M4 x 7	-	6	M3 x 6.5	M3 x 6	P3	3.5	8.5	11.5	9.8	10.9	0.18	1.29
32	M5 x 8.5	-	8	M3 x 7.5	M3 x 5.5	P4	10	6	9.4	11	11.7	0.32	2.28
32	M5 x 8.5	-	8	M3 x 7.5	M3 x 5.5	P4	10	6	9.4	13.1	13.8	0.40	2.28
35	M6 x 9	-	12	M6 x 7.5	M3 x 6.5	P4	12	12	16.3	16.6	17.6	0.58	3.02
35	M6 x 9	-	12	M6 x 7.5	M3 x 6.5	P4	12	12	16.3	21	22	0.69	3.02
40	M8 x 12	-	12	M6 x 8.5	M6 x 5	P5	12	10.5	15	20.8	20.5	0.90	4.38
40	M8 x 12	-	12	M6 x 8.5	M6 x 5	P5	12	10.5	15	21.7	21.8	1.15	4.38
50	M8 x 13	-	14	M6 x 10	M6 x 7	P5	12	15	22	23.4	24.1	1.43	6.79
50	M8 x 13	-	14	M6 x 10	M6 x 7	P5	12	15	22	25.1	25.8	1.95	6.79
60	M10 x 20	-	14	PT1/8 x 12.5	M6 x 10.5	P5	14	21.1	28.1	27.3	27.3	2.79	10.53
60	M10 x 20	-	14	PT1/8 x 12.5	M6 x 10.5	P5	14	21.1	28.1	35	35	4.06	10.53

Tab. 4

Series MRT0 / MRT0...S – carriage with flange



Type	System [mm]		Rail [mm]								
	H	W <sub>2</sub>	W <sub>1</sub>	H <sub>1</sub>	P	D x d x g <sub>1</sub>	W	L	L <sub>1</sub>	h <sub>2</sub>	P <sub>1</sub>
MRT015	24	18.5	15	15	60	7.5 x 4.5 x 5.3	52	55.5	40.3	20.7	26
MRT015S	24	18.5	15	15	60	7.5 x 4.5 x 5.3	52	41.2	26	20.7	-
MRT020	28	19.5	20	20	60	9.5 x 6 x 8.5	59	69	52	23	32
MRT020S	28	19.5	20	20	60	9.5 x 6 x 8.5	59	49.2	32.2	23	-
MRT025	33	25	23	23	60	11 x 7 x 9	73	81.2	62.2	27	35
MRT025S	33	25	23	23	60	11 x 7 x 9	73	57.4	38.4	27	-
MRT030	42	31	28	27	80	14 x 9 x 12	90	95.5	71.5	35.2	40
MRT030S	42	31	28	27	80	14 x 9 x 12	90	68	44	35.2	-
MRT035	48	33	34	32	80	14 x 9 x 12	100	111.2	86.2	40.4	50

The short carriages (MRT0...S) are equipped with only two mounting holes.



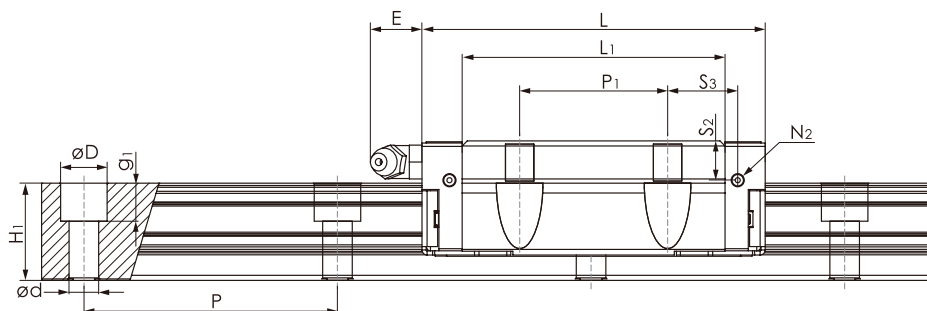
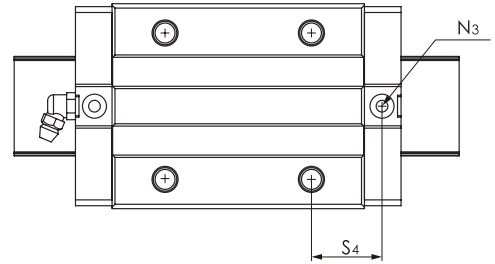
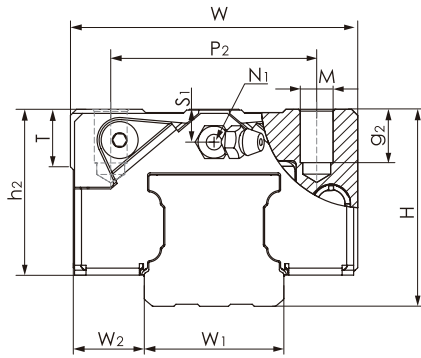

Fig. 14

Slider [mm]												Weight	
P <sub>2</sub>	M x g <sub>2</sub>	M <sub>1</sub>	T	N <sub>1</sub>	N <sub>2</sub>	N <sub>3</sub>	E	S <sub>1</sub>	S <sub>2</sub>	S <sub>3</sub>	S <sub>4</sub>	Slider [kg]	Rail [kg/m]
41	M5 x 7	M4	7	M3 x 6.5	M3 x 6	P3	3.5	4.5	7.5	8.9	10.9	0.18	1.29
41	M5 x 7	M4	7	M3 x 6.5	M3 x 6	P3	3.5	4.5	7.5	15.7	16.8	0.12	1.29
49	M6 x 10	M5	10	M3 x 7.5	M3 x 5.5	P4	10	4	7.4	13	13.7	0.34	2.28
49	M6 x 10	M5	10	M3 x 7.5	M3 x 5.5	P4	10	4	7.4	19.1	19.8	0.21	2.28
60	M8 x 12	M6	12	M6 x 7.5	M3 x 6.5	P4	12	5	9.3	16.6	17.6	0.52	3.02
60	M8 x 12	M6	12	M6 x 7.5	M3 x 6.5	P4	12	5	9.3	22.2	23.2	0.35	3.02
72	M10 x 15	M8	15	M6 x 8.5	M6 x 5	P5	12	7.5	12	20.8	20.5	1.20	4.38
72	M10 x 15	M8	15	M6 x 8.5	M6 x 5	P5	12	7.5	12	27	26.8	0.75	4.38
82	M10 x 15	M8	15	M6 x 10	M6 x 7	P5	12	8	15	23.4	24.1	1.58	6.79

Tab. 5

Series MRT0...W / MRT0...SW / MRT0...LW – carriage without flange



Type	System [mm]		Rail [mm]								
	H	W <sub>2</sub>	W <sub>1</sub>	H <sub>1</sub>	P	D x d x g <sub>1</sub>	W	L	L <sub>1</sub>	h <sub>2</sub>	P <sub>1</sub>
MRT015W	24	9.5	15	15	60	7.5 x 4.5 x 5.3	34	55.5	40.3	20.7	26
MRT015SW	24	9.5	15	15	60	7.5 x 4.5 x 5.3	34	41.2	26	20.7	-
MRT020W	28	11	20	20	60	9.5 x 6 x 8.5	42	69	52	23	32
MRT020SW	28	11	20	20	60	9.5 x 6 x 8.5	42	49.2	32.2	23	-
MRT025W	33	12.5	23	23	60	11 x 7 x 9	48	81.2	62.2	27	35
MRT025SW	33	12.5	23	23	60	11 x 7 x 9	48	57.4	38.4	27	-
MRT030W	42	16	28	27	80	14 x 9 x 12	60	95.5	71.5	35.2	40
MRT030SW	42	16	28	27	80	14 x 9 x 12	60	68	44	35.2	-
MRT030LW	42	16	28	27	80	14 x 9 x 12	60	118	94	35.2	60
MRT035W	48	18	34	32	80	14 x 9 x 12	70	111.2	86.2	40.4	50
MRT035LW	48	18	34	32	80	14 x 9 x 12	70	136.6	111.6	40.4	72
MRT045W	60	20.5	45	39	105	20 x 14 x 17	86	135.5	102.5	50.7	60
MRT045LW	60	20.5	45	39	105	20 x 14 x 17	86	171.5	138.5	50.7	80

The short carriages (MRT0...SW) are equipped with only two mounting holes.

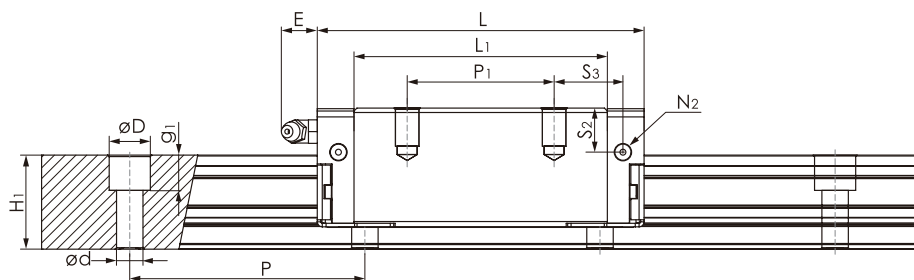
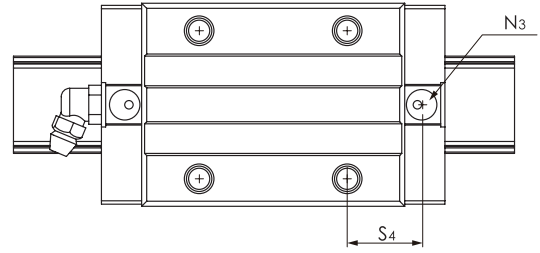
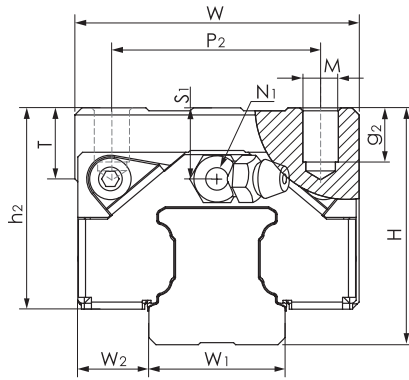

Fig. 15

Slider [mm]												Weight	
P <sub>2</sub>	M x g <sub>2</sub>	M <sub>1</sub>	T	N <sub>1</sub>	N <sub>2</sub>	N <sub>3</sub>	E	S <sub>1</sub>	S <sub>2</sub>	S <sub>3</sub>	S <sub>4</sub>	Slider [kg]	Rail [kg/m]
26	M4 x 7	-	6	M3 x 6.5	M3 x 6	P3	3,5	4.5	7.5	9.8	10.9	0.14	1.29
26	M4 x 7	-	6	M3 x 6.5	M3 x 6	P3	3,5	4.5	7.5	15.7	16.8	0.10	1.29
32	M5 x 7	-	8	M3 x 7.5	M3 x 5.5	P4	10	4	7.4	13	13.7	0.27	2.28
32	M5 x 7	-	8	M3 x 7.5	M3 x 5.5	P4	10	4	7.4	19.1	19.8	0.17	2.28
35	M6 x 9	-	8	M6 x 7.5	M3 x 6.5	P4	12	5	9.3	16.6	17.6	0.42	3.02
35	M6 x 9	-	8	M6 x 7.5	M3 x 6.5	P4	12	5	9.3	22.2	23.2	0.30	3.02
40	M8 x 10	-	12	M6 x 8.5	M6 x 5	P5	12	7.5	12	20.8	20.5	0.80	4.38
40	M8 x 10	-	12	M6 x 8.5	M6 x 5	P5	12	7.5	12	27	26.7	0.56	4.38
40	M8 x 10	-	12	M6 x 8.5	M6 x 5	P5	12	8.7	12	21.7	21.7	1.14	4.38
50	M8 x 13	-	14	M6 x 10	M6 x 7	P5	12	8	15	23.4	24.1	1.12	6.79
50	M8 x 13	-	14	M6 x 10	M6 x 7	P5	12	8	15	25.1	25.8	1.54	6.79
60	M10 x 20	-	14	PT1/8 x 12.5	M6 x 10.5	P5	14	11.1	18.1	27.3	27.2	2.12	10.53
60	M10 x 20	-	14	PT1/8 x 12.5	M6 x 10.5	P5	14	11.1	18.1	35	35	3.16	10.53

Tab. 6

Series MRZO...W / MRZO...LW – carriage without flange



Type	System [mm]		Rail [mm]								
	H	W <sub>2</sub>	W <sub>1</sub>	H <sub>1</sub>	P	D x d x g <sub>1</sub>	W	L	L <sub>1</sub>	h <sub>2</sub>	P <sub>1</sub>
MRZO25W	36	12.5	23	23	60	11 x 7 x 9	48	81.2	62.2	30	35
MRZO25LW	36	12.5	23	23	60	11 x 7 x 9	48	105	86	30	50

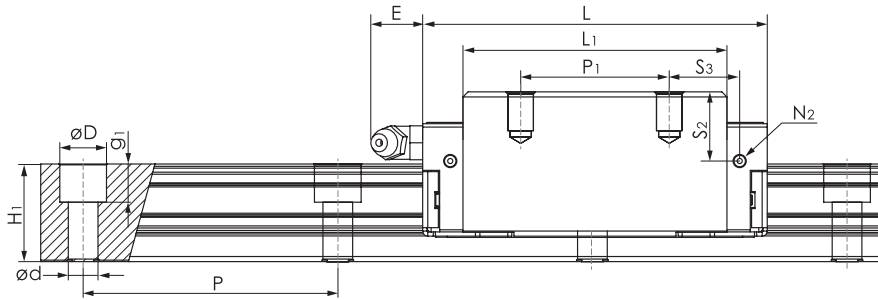

Fig. 16

Slider [mm]												Weight	
P <sub>2</sub>	M x g <sub>2</sub>	M <sub>1</sub>	T	N <sub>1</sub>	N <sub>2</sub>	N <sub>3</sub>	E	S <sub>1</sub>	S <sub>2</sub>	S <sub>3</sub>	S <sub>4</sub>	Slider [kg]	Rail [kg/m]
35	M6 x 9	-	8	M6 x 7.5	M3 x 6.5	P4	12	8	12.3	16.6	17.6	0.47	3.02
35	M6 x 9	-	8	M6 x 7.5	M3 x 6.5	P4	12	8	12.3	21	22	0.61	3.02

Tab. 7

## Series MRRO...F – rail mounted from below

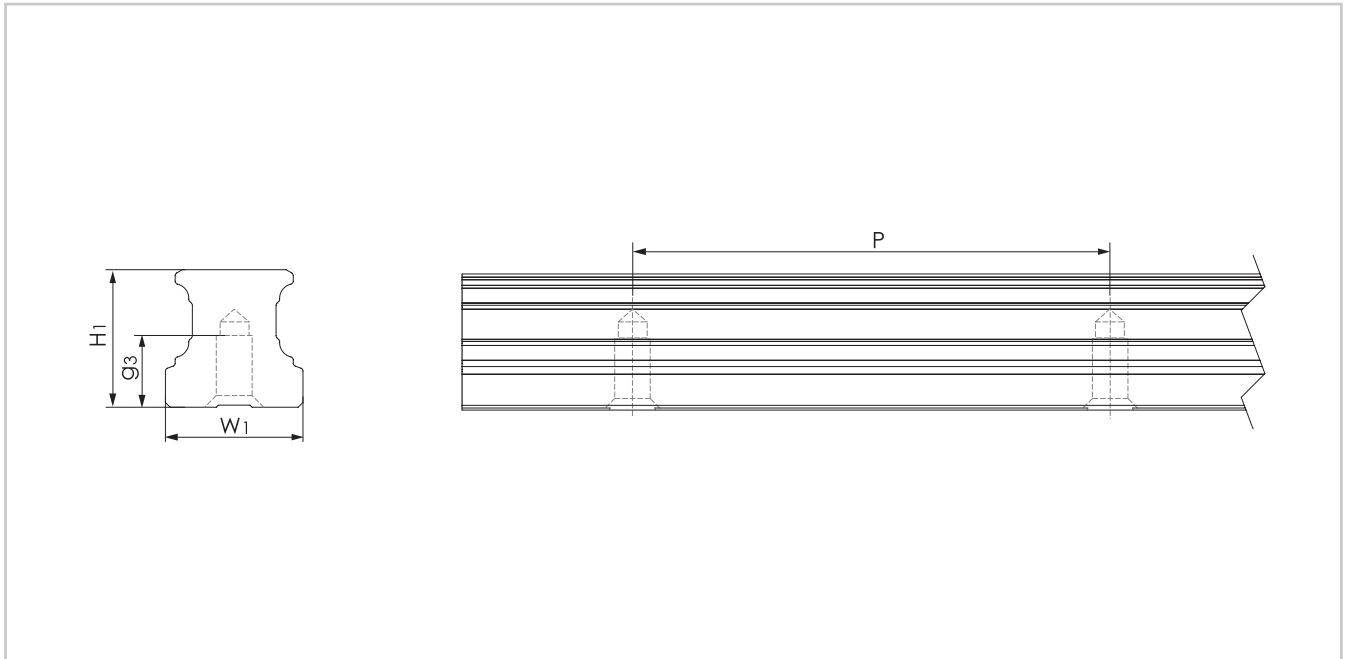

Fig. 17

Rail type	$W_1$ [mm]	$H_1$ [mm]	P [mm]	M x $g_3$ [mm]	$L_{max}$ [mm]	Rail [kg/m]
MRRO15...F	15	15	60	M5 x 7.5	4000	1.29
MRRO20...F	20	20	60	M6 x 9	4000	2.28
MRRO25...F	23	23	60	M6 x 12	4000	3.02
MRRO30...F	28	27	80	M8 x 15	4000	4.38
MRRO35...F	34	32	80	M8 x 20	4000	6.79
MRRO45...F	45	39	105	M12 x 20	4000	10.53

Tab. 8

# Ordering Key



## > Rail

<b>MRRO</b>	<b>20</b>	<b>6860</b>	<b>N</b>	<b>F</b>	<b>T</b>	<b>XXX</b>
SRail type		Size		Total rail length		Precision class
				Rail mounted from below, optional		Joint processed rails, optional
						Surface coating on request

Ordering example: MRRO20-06850-NF-T

Rail composition: 1x2920+1x3940 (only for joint processed rails)

Hole pattern: 10-48x60-30//30-65x60-10 (always specify hole pattern separately)

Notes on ordering: The rail lengths are always indicated as 5 digits with 0 prefixes

## > Carriage

<b>MRS035</b>	<b>N</b>	<b>V1</b>	<b>A</b>	<b>XXX</b>
Type		Precision class		Preload class
			Sealing variants	
			Surface coating on request	

Ordering example: MRS035-N-V1-A





**ROLLON**<sup>®</sup>

Linear Evolution

*Curviline*

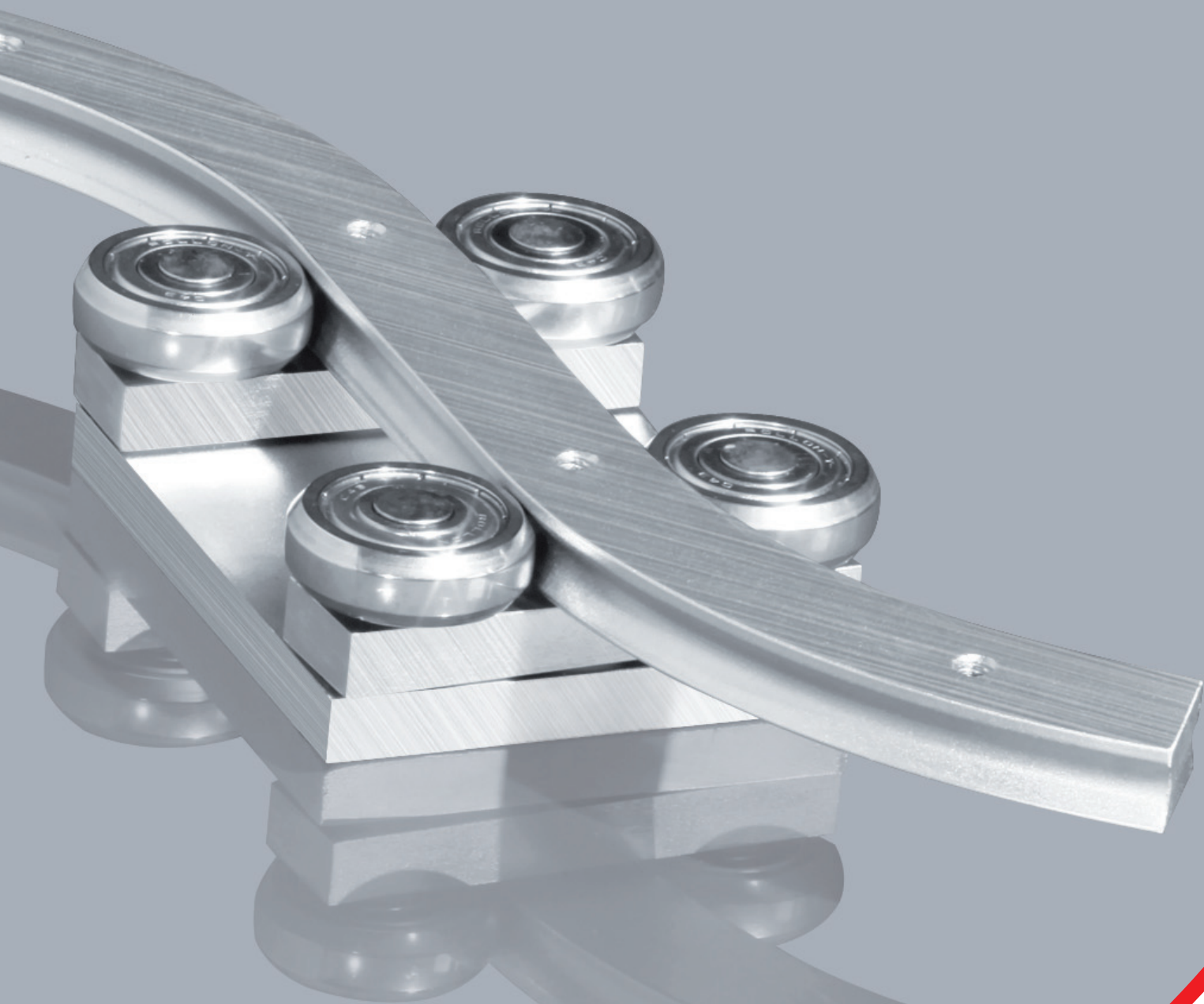



## Product explanation



### > Curviline are curvilinear rails for constant and variable radii



Fig. 1

Curviline is the name of the curvilinear rail product family that is used for all non-linear special movements. Rails with constant or variable radii may be specified according to customer requirements, resulting in a highly flexible, economical solution. Curviline is available in two rail widths.

The use of standard radii is recommended. All non-standard rail layouts and radii are possible as custom products, however extra lead time may result.

#### Preferred areas of application of the Curviline product family:

- Packaging machines
- Railway car interior doors
- Special extensions
- Shipbuilding (interior doors)
- Food industry

#### The most important characteristics:

- Straight and curved sections in one continuous rail is possible
- Sliders with four rollers arranged in pairs maintain the preload over the entire rail length
- Custom production according to customer requirements
- Also available in stainless steel

### Constant radii

The layout of CKR guide rails corresponds to a partial section of a complete circle.

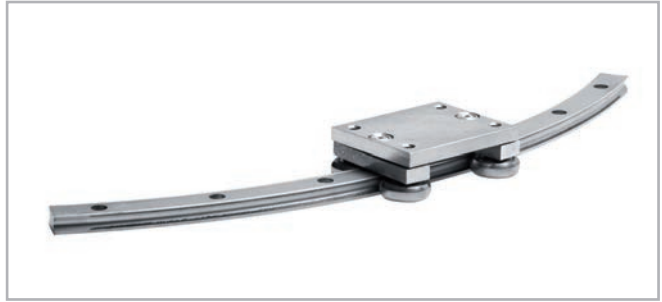

Fig. 2

### Variable radii

CVR curvilinear rail is a combination of variable radii and straight sections.



Fig. 3

### Straight rail

The linear rail Curviline is also available in its straight version.



Fig. 4

### Slider

The carriage maintains the desired preload over the entire rail layout. Pivoting roller mounts coupled with concentric and eccentric rollers allows for a smooth operation over complex rail layouts.



Fig. 5

## Technical data

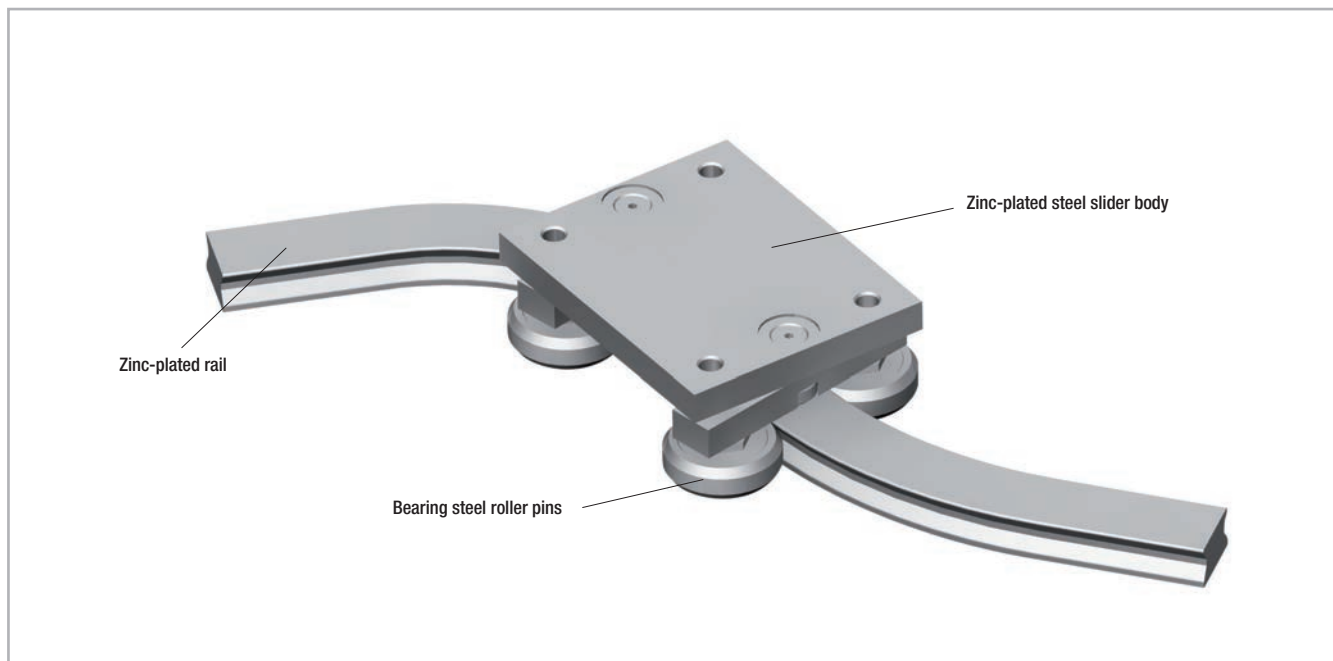

Fig. 6

### Performance characteristics:

- Available rail widths: CKR01/CVR01: 16.5 mm (0.65 in) and CKR05/CVR05: 23 mm (0.91 in)
- Max. slider operating speed on the rail: 1.5 m/s (59 in/s) (depending on application)
- Max. acceleration: 2 m/s<sup>2</sup> (78 in/s<sup>2</sup>) (depending on application)
- Max. effective length of the rail: 3,240 mm (127.56 in)
- Max. traverse: CCT08: 3,170 mm (124.8 in) and CCT11: 3,140 mm (123.62 in)
- Minimum radius for steel version and not hardened version: 120 mm
- Minimum radius for version with hardened raceways: 300 mm for section 01, 400 mm for size 05  
For non-standard radii, please contact Rollon technical support.
- Radius tolerance +/- 0.5 mm (0.02 in), angle tolerance +/- 1°
- Temperature range: -30 °C to +80 °C (-22 °F to +176 °F)
- Rail and runner electrolytic zinc-plated and passivated (Rollon Aloy); increased anticorrosive protection on request (see pg. CL-10 Anticorrosive protection)
- Rail material: C43, AISI316L for the stainless steel version
- Slider body material: Fe360, AISI316L for the stainless steel version
- Radial ball bearing roller material: 100Cr6, AISI440 for the stainless steel version
- Rollers are lubricated for life

### Remarks:

- With a simple adjustment of the eccentric roller (denoted with a marking on the bottom of the roller), the slider preload can be set to desired preload, including clearance.
- The recommended hole pitch is 80 mm (3.15 in) on the extended length
- Please indicate the precise rail layout and the desired hole pattern in a drawing
- Indicate if the design is a right or left version when ordering
- Joined rails are not recommended. For more information, please contact Rollon technical support.
- Resulting moment loads must be absorbed through the use of two sliders. For more information, please contact Rollon technical support.

# Product dimensions

## > Rails with constant/variable radii with tempered raceways

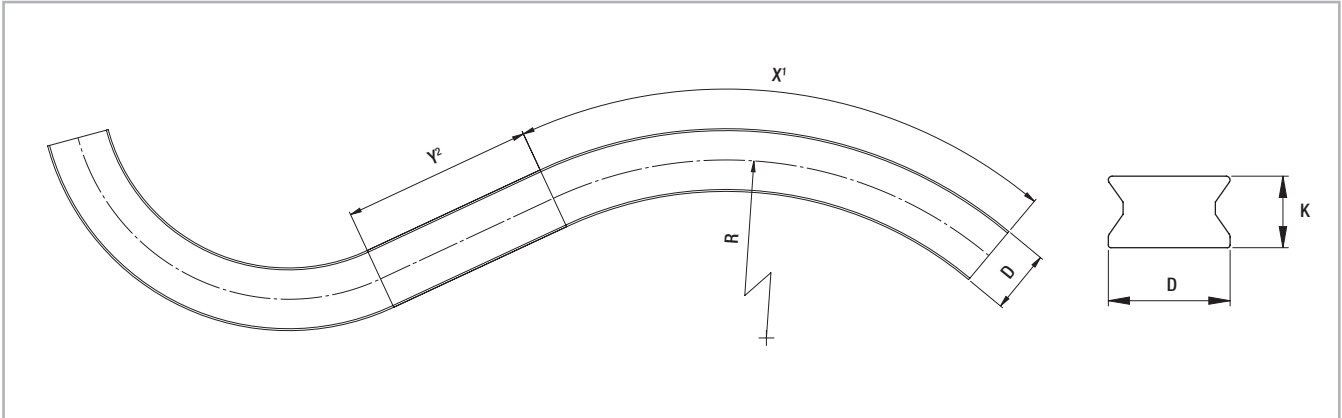

<sup>1</sup> The max. angle (X) is dependent on the radius

<sup>2</sup> For curvilinear rails with variable radii, Y must be at least 70 mm

Fig. 7

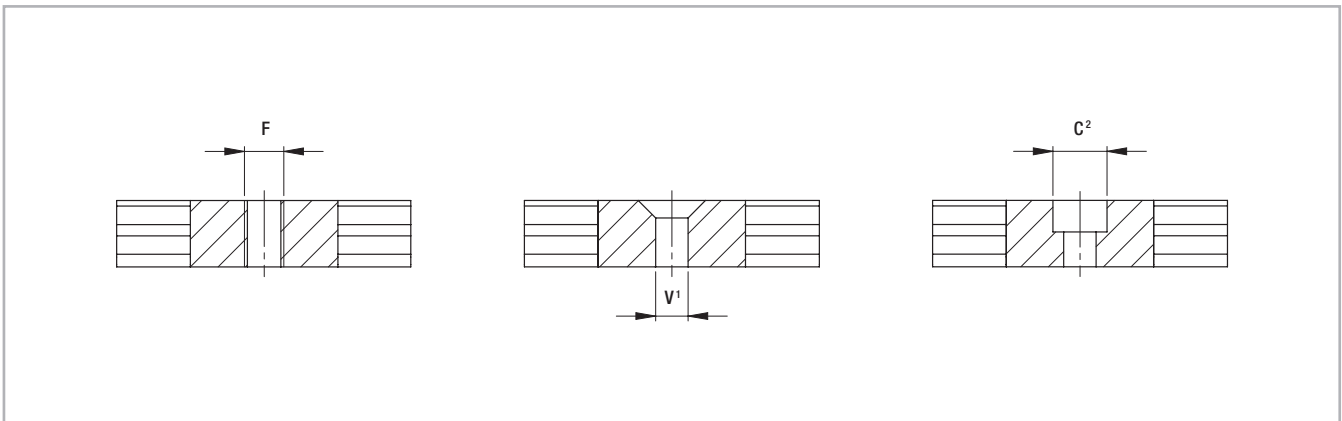

<sup>1</sup> Fixing holes (V) for countersunk head screws according to DIN 7991

<sup>2</sup> Fixing holes (C) for socket cap screws according to DIN 912

Fig. 8

Type	D [mm]	K [mm]	F	C <sup>2</sup>	V <sup>1</sup>	X	Standard radii [mm]	Y [mm]	Weight [kg/m]
CKRH01 CVRH01	16,5	10	up to M6	up to M5	up to M5	dependent on radius	300* - 400 - 500 - 600 - 700 - 800 - 900 - 1000	min. 70	1,2
CKRH05 CVRH05	23	13,5	up to M8	up to M6	up to M6				2,2

\* Only for size 01

Tab. 1

Please indicate the precise rail layout and the desired hole pattern in a drawing. We recommend 80 mm (3.15 in) on the extended length as a gage for the hole pattern.

Non-standard radii are possible as special products. For more information on rail layouts, radii and hole patterns, please contact Rollon Technical Support.

> Slider

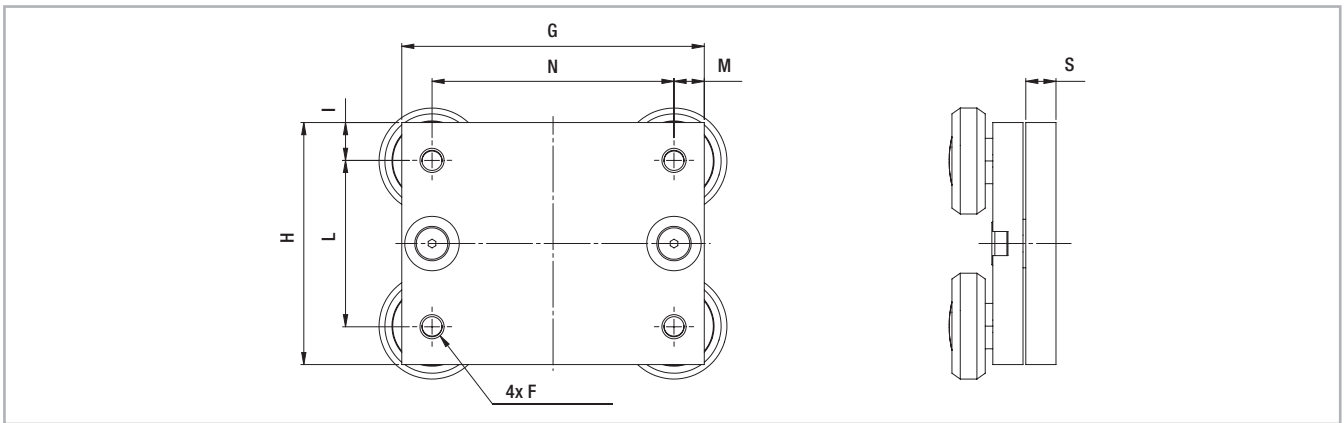

Fig. 9

Type	G [mm]	H [mm]	I [mm]	L [mm]	M [mm]	N [mm]	S [mm]	F	Weight [kg]
CCT08	70	50	10	30	10	50	10	M5	0,45
CCT11	100	80	12,5	55	10	80	10	M8	1,1

Tab. 2

> Mounted sliders and rails

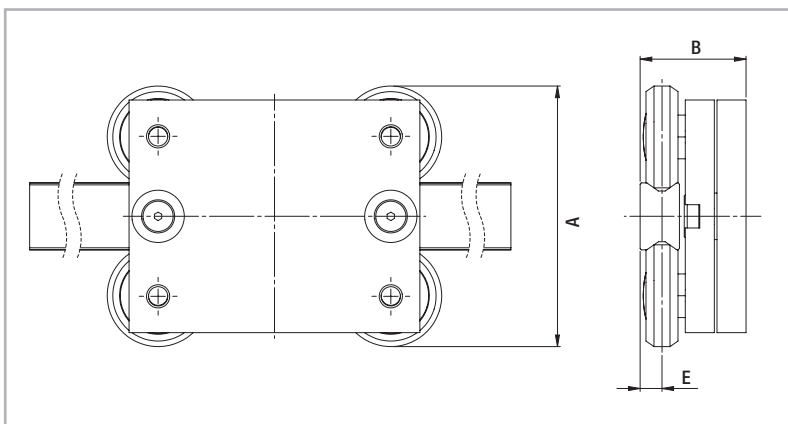

Fig. 10

Configuration	A [mm]	B [mm]	E [mm]
CKRH01-CCT08 CVRH01-CCT08	60	32,3	5,7
CKRH05-CCT11 CVRH05-CCT11	89,5	36,4	7,5

Tab. 3

> Load capacities

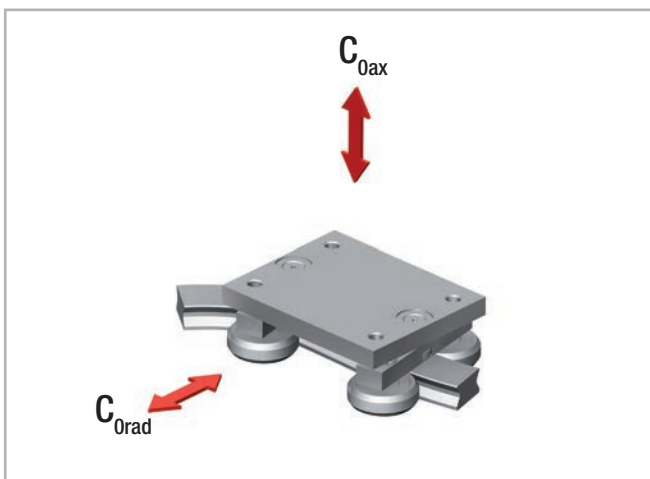

Fig. 11

Slider type	Load capacities	
	$C_{0rad}$ [N]	$C_{0ax}$ [N]
CKRH01-CCT08 CVRH01-CCT08	980	592
CKRH05-CCT11 CVRH05-CCT11	2475	1459

Resulting moment loads must be absorbed through the use of two sliders

Tab. 4

> Rails with constant/variable radii in carbon steel

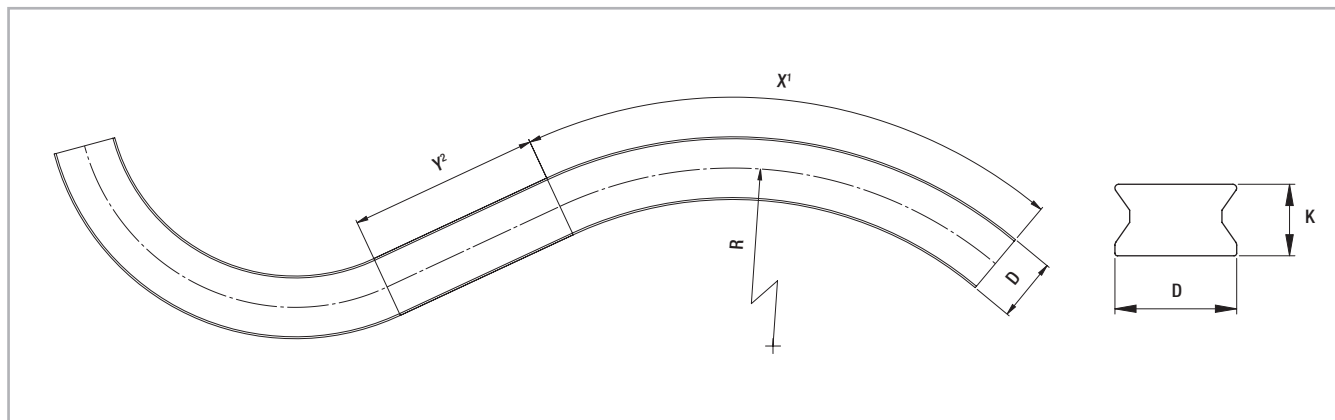

<sup>1</sup> The max. angle (X) is dependent on the radius

<sup>2</sup> For curvilinear rails with variable radii, Y must be at least 70 mm

Fig. 12

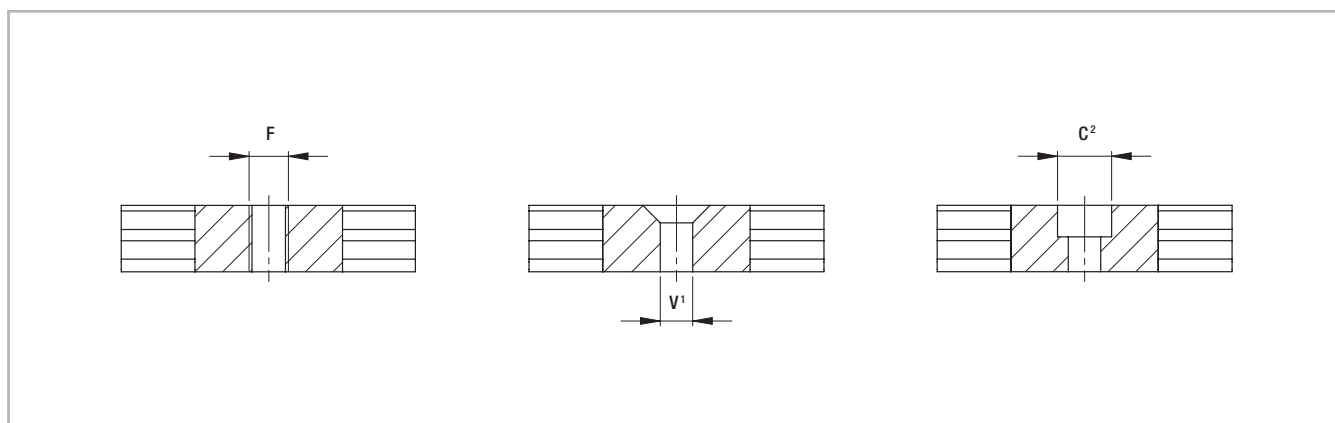

<sup>1</sup> Fixing holes (V) for countersunk head screws according to DIN 7991

<sup>2</sup> Fixing holes (C) for socket cap screws according to DIN 912

Fig. 13

Type	D [mm]	K [mm]	F	C <sup>2</sup>	V <sup>1</sup>	X	Standard radii [mm]	Y [mm]	Weight [kg/m]
CKR01 CVR01	16,5	10	up to M6	up to M5	up to M5	dependent on radius	150 - 200 - 250 - 300 - 400 - 500 - 600 - 700 - 800 - 900 - 1000	min. 70	1,2
CKR05 CVR05	23	13,5	up to M8	up to M6	up to M6				2,2

Tab. 5

Please indicate the precise rail layout and the desired hole pattern in a drawing. We recommend 80 mm (3.15 in) on the extended length as a gage for the hole pattern.

Non-standard radii are possible as special products. For more information on rail layouts, radii and hole patterns, please contact Rollon Technical Support.



> Slider

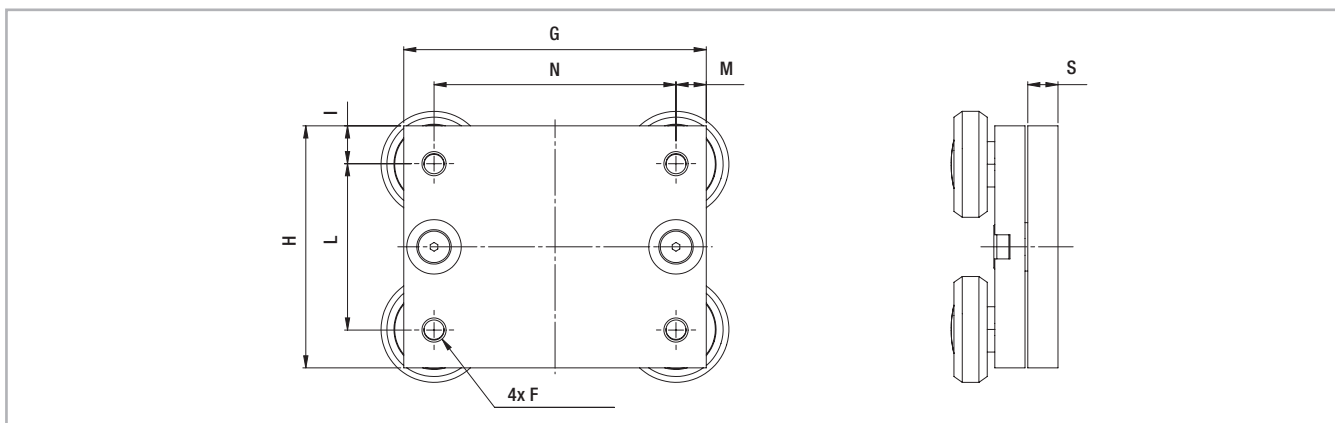

Fig. 14

Type	G [mm]	H [mm]	I [mm]	L [mm]	M [mm]	N [mm]	S [mm]	F	Weight [kg]
CCT08	70	50	10	30	10	50	10	M5	0,45
CCT11	100	80	12,5	55	10	80	10	M8	1,1

Tab. 6

> Mounted sliders and rails

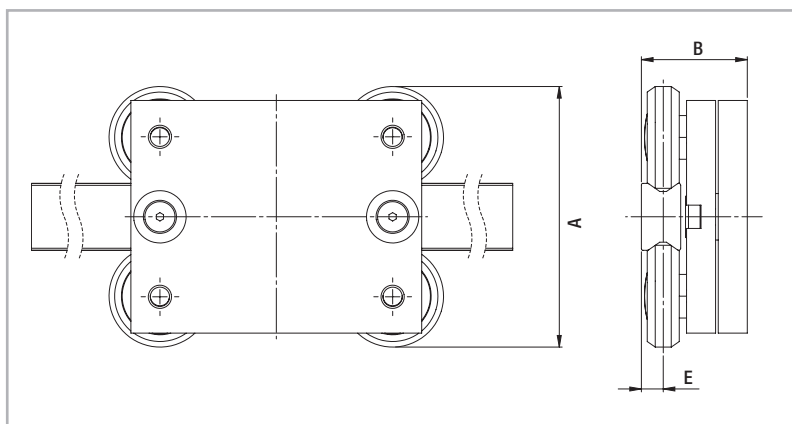

Fig. 15

Configuration	A [mm]	B [mm]	E [mm]
CKR01-CCT08 CVR01-CCT08	60	32,3	5,7
CKR05-CCT11 CVR05-CCT11	89,5	36,4	7,5

Tab. 7

> Load capacities

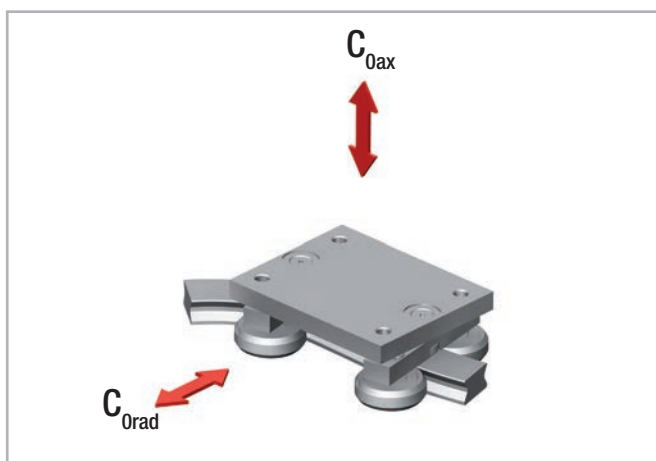

Fig. 16

Slider type	Load capacities	
	$C_{0ax}$ [N]	$C_{0rad}$ [N]
CKR01-CCT08 CVR01-CCT08	400	570
CKR05-CCT11 CVR05-CCT11	1130	1615

Resulting moment loads must be absorbed through the use of two sliders

Tab. 8

> Rails with constant/variable radii in stainless steel

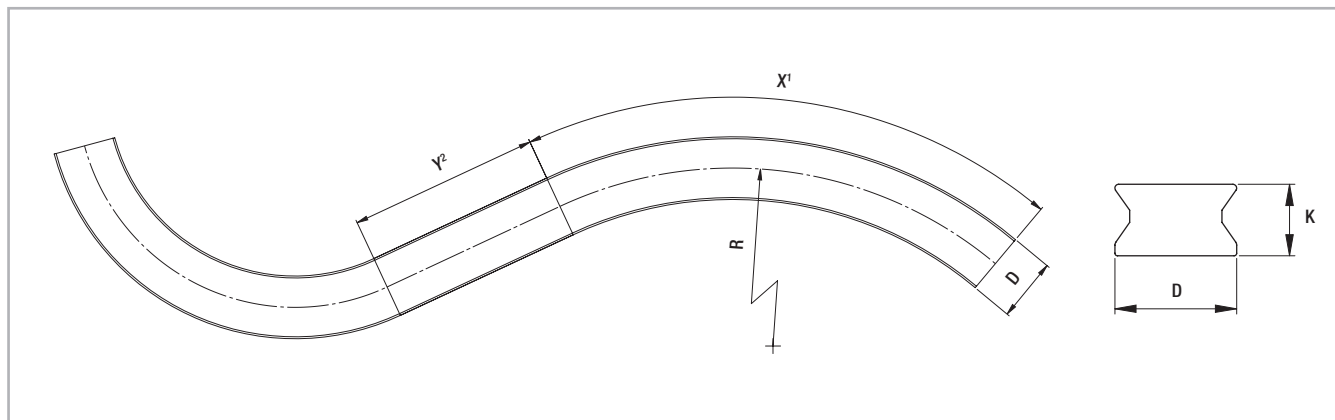

<sup>1</sup> The max. angle (X) is dependent on the radius

<sup>2</sup> For curvilinear rails with variable radii, Y must be at least 70 mm

Fig. 17

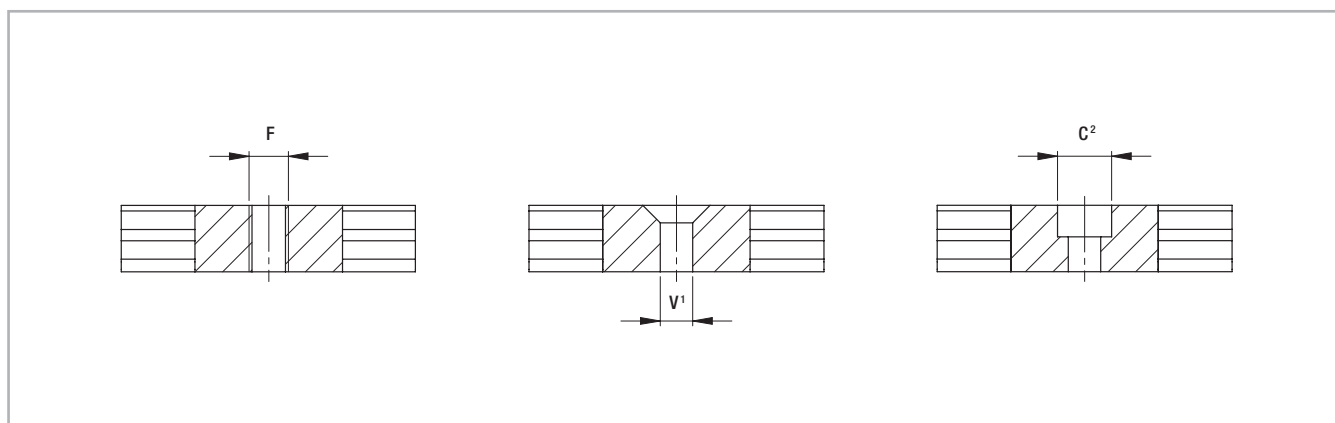

<sup>1</sup> Fixing holes (V) for countersunk head screws according to DIN 7991

<sup>2</sup> Fixing holes (C) for socket cap screws according to DIN 912

Fig. 18

Type	D [mm]	K [mm]	F	C <sup>2</sup>	V <sup>1</sup>	X	Standard radii [mm]	Y [mm]	Weight [kg/m]
CKRX01 CVRX01	16,5	10	up to M6	up to M5	up to M5	dependent on radius	150 - 200 - 250 - 300 - 400 - 500 - 600 - 700 - 800 - 900 - 1000	min. 70	1,2
CKRX05 CVRX05	23	13,5	up to M8	up to M6	up to M6				2,2

Tab. 9

Please indicate the precise rail layout and the desired hole pattern in a drawing. We recommend 80 mm (3.15 in) on the extended length as a gage for the hole pattern.

Non-standard radii are possible as special products. For more information on rail layouts, radii and hole patterns, please contact Rollon Technical Support.

> Slider in stainless steel

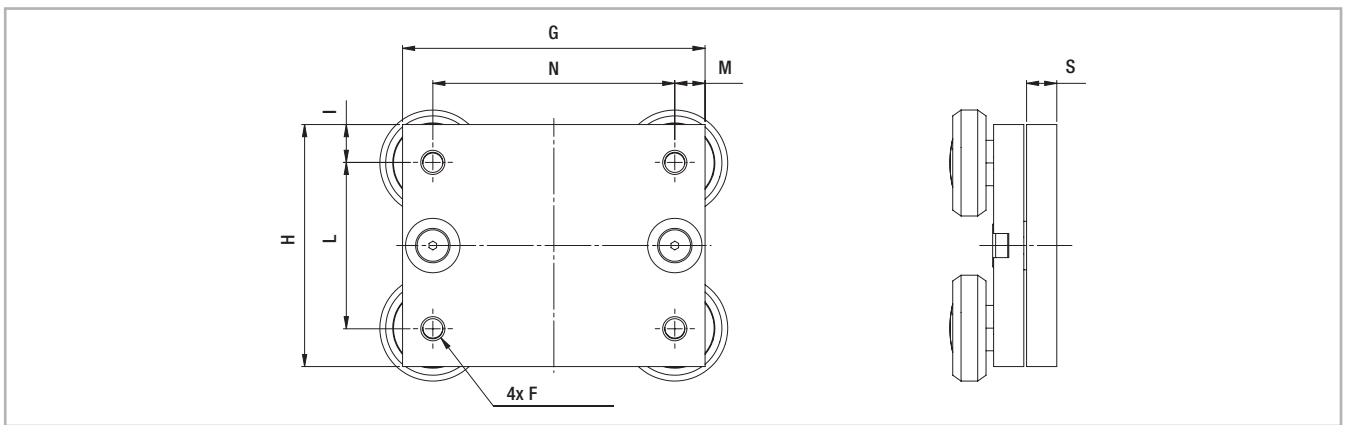

Fig. 19

Type	G [mm]	H [mm]	I [mm]	L [mm]	M [mm]	N [mm]	S [mm]	F	Weight [kg]
CCTX08	70	50	10	30	10	50	10	M5	0,45
CCTX11	100	80	12,5	55	10	80	10	M8	1,1

Tab. 10

> Rail-slider package in stainless steel

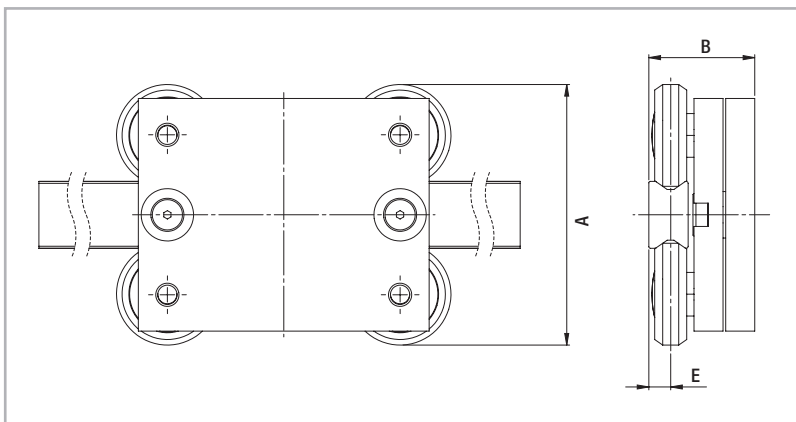

Fig. 20

Configuration	A [mm]	B [mm]	E [mm]
CKRX01-CCTX08 CVRX01-CCTX08	60	32,3	5,7
CKRX05-CCTX11 CVRX05-CCTX11	89,5	36,4	7,5

Tab. 11

> Load capacities

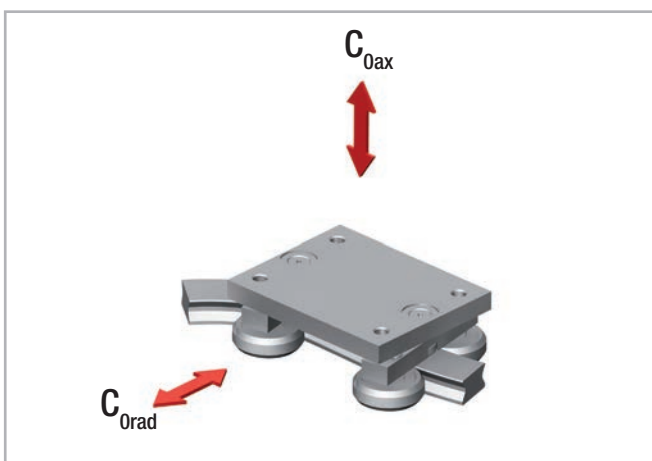

Fig. 21

Slider type	Load capacities	
	C <sub>0ax</sub> [N]	C <sub>0rad</sub> [N]
CKRX01-CCTX08 CVRX01-CCTX08	400	570
CKRX05-CCTX11 CVRX05-CCTX11	1130	1615

Resulting moment loads must be absorbed through the use of two sliders

Tab. 12

# Technical instructions



## > Anticorrosive protection

The Curviline product family comes standard with electrolytic zinc plating with passivation (RolonAloy) for anticorrosion protection. If increased anticorrosive protection is required, application-specific surface treatments

are available on request, e.g. as nickel-plated design with FDA approval for use in the food industry. The Curviline series is also available in stainless steel. For more information, please contact Rollon technical support.

## > Lubrication

### Roller lubrication

All rollers of the Curviline product family are lubricated for life.

### Lubrication of the raceways

Rails must be lubricated before operation. Recommended lubrication intervals are heavily dependent upon the ambient conditions, speed and temperature. Under normal conditions, lubrication is recommended after 100 km operational performance or after an operating period of six months. In critical application cases the interval should be shorter. Please clean the raceways carefully before lubrication.

We recommend a roller bearing lubricant with a lithium base of average consistency.

Proper lubrication during normal conditions:

- reduces friction
- reduces wear
- reduces the load of the contact surfaces through elastic deformations
- reduces running noise

Different lubricants are available by request for special applications:

- FDA-approved lubricant for use in the food industry
- specific lubricant for clean rooms
- specific lubricant for the marine technology sector
- specific lubricant for high and low temperatures

For specific information, contact Rollon technical support.

## > Setting the preload

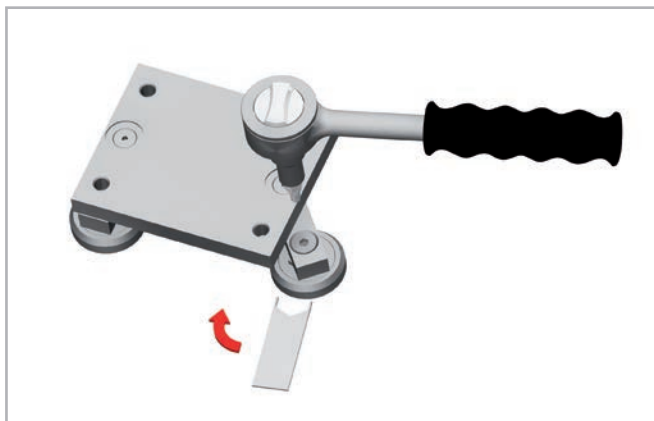

Fig. 22

If the curvilinear rails are delivered as a system, the sliders are already set with no clearance. In this case the fixing screws are secured with Loctite® at the factory.

If delivered separately, or if the sliders should be installed in another track, the eccentric roller pins must be readjusted. Important: The fixing screws must be additionally glued against loosening. The following points must also be observed:

- Wipe the raceways of any dirt and debris.
- Slightly loosen the fixing screws of the roller mounting.  
The eccentric roller pins are marked on the bottom.
- Position the slider(s) at the ends of the rail.
- The special flat key provided is inserted from the side onto the hexagonal of the roller to be set (see fig. 22).

Type	Tightening torque [Nm]
CCT08	7
CCT11	12

Tab. 13

- By turning the flat key clockwise the roller is pressed against the raceway and thus reduces the clearance. Observe that with increasing preload, the friction is also increased and thus the service life reduced.
- Hold the roller pin with the adjustment key in the desired position and carefully tighten the fixing screw. The exact tightening torque will be checked later.
- Move the slider on the rail and check the preload over the entire length of the rail. It should move easily and the slider should not have play at any location of the rail.
- Now tighten the fixing screws with the specified tightening torque (see tab. 13), while the flat key holds the angle adjustment of the pin. A special thread in the roller pin secures the set position.

# Ordering key

## > Constant radius rail / slider system

CKR01	85°	600	890	/2/	CCT08	NIC	R	
								Right or left version
								Expanded surface protection if deviation from Standard <i>see pg. CL-12 Anticorrosion protection</i>
								Slider type <i>see pg. CL-7, tab. 3</i>
								Number of sliders
								Rails extended length
								Radius <i>see pg. CL-6, tab. 1</i>
								Angle
								Rail type <i>see pg. CL-6, tab. 1</i>

Ordering example: CKR01-085°-0600-0890/2/CCT08-NIC-R

Note: Information for right and left side installation and for expanded surface protection is only necessary if required

Notes on ordering: Rail lengths and radii always are indicated with four digits, angles always with three digits and a zero as prefix

Exact specifications (angle, radius, hole pattern, etc.) must be represented in a drawing

## > Variable radius rail / slider system

CVR01	39°	200	//23°	400	297	/2/	CCT08	NIC	R
									Right or left version
									Expanded surface protection if deviation from Standard <i>see pg. CL-8 Anticorrosion protection</i>
									Slider type <i>see pg. CL-7, tab. 3</i>
									Number of sliders
									Rails extended length
									Radius <i>see pg. CL-6, tab. 1</i>
									Angle
									Radius <i>see pg. CL-6, tab. 1</i>
									Angle
									Rail type <i>see pg. CL-6, tab. 1</i>

Ordering example: CVR01-039°-0200//023°-0400-0297/2/CCT08-NIC-R

Note: Data for angles and respective radii are in sequential order

Note: Information for right and left side installation and for expanded surface protection is only necessary if required

Notes on ordering: Rail lengths and radii always are indicated with four digits, angles always with three digits and a zero as prefix

Exact specifications ( layout, angle, radius, hole pattern, etc.) must be represented in a drawing

> **Constant radius rails**

<b>CKR01</b>	<b>120°</b>	<b>600</b>	<b>1152</b>	<b>NIC</b>	<b>R</b>	
						Right or left version
						Expanded surface protection if deviation from Standard <i>see pg. CL-12 Anticorrosion protection</i>
						Rails extended length
		Radius	<i>see pg. CL-6, tab. 1</i>			
	Angle					
Rail type	<i>see pg. CL-6, tab. 1</i>					

Ordering example: CKR01-120°-0600-1152-NIC-R

Note: Information for right and left side installation and for expanded surface protection is only necessary if required

Notes on ordering: Rail lengths and radii always are indicated with four digits, angles always with three digits and a zero as prefix

Exact specifications (angle, radius, hole pattern, etc.) must be represented in a drawing

> **Variable radius rails**

<b>CVR01</b>	<b>39°</b>	<b>200</b>	<b>//23°</b>	<b>400</b>	<b>297</b>	<b>NIC</b>	<b>R</b>
							Right or left version
							Expanded surface protection if deviation from Standard <i>see pg. CL-12 Anticorrosion protection</i>
							Rails extended length
		Radius	<i>see pg. CL-6, tab. 1</i>				
	Angle						
		Radius	<i>see pg. CL-6, tab. 1</i>				
	Angle						
Rail type	<i>see pg. CL-6, tab. 1</i>						

Ordering example: CVR01-039°-0200//023°-0400-0297-NIC-R

Note: Data for various angles and respective radii are in sequential order

Note: Information for right and left side installation and for expanded surface protection is only necessary if required

Notes on ordering: Rail lengths and radii always are indicated with four digits, angles always with three digits and a zero as prefix

Exact specifications ( layout, angle, radius, hole pattern, etc.) must be represented in a drawing

> **Slider**

<b>CCT08</b>	<b>NIC</b>	
		Expanded surface protection if deviation from Standard <i>see pg. CL-12 Anticorrosion protection</i>
Slider type	<i>see pg. CL-7, tab. 3</i>	

Ordering example: CCT08-NIC

Note: Information for expanded surface protection are only necessary when needed



**Pacific International  
Bearing, Inc.**  
800.228.8895 • [www.pibsales.com](http://www.pibsales.com)

Guides suitable for all applications



**Railway**

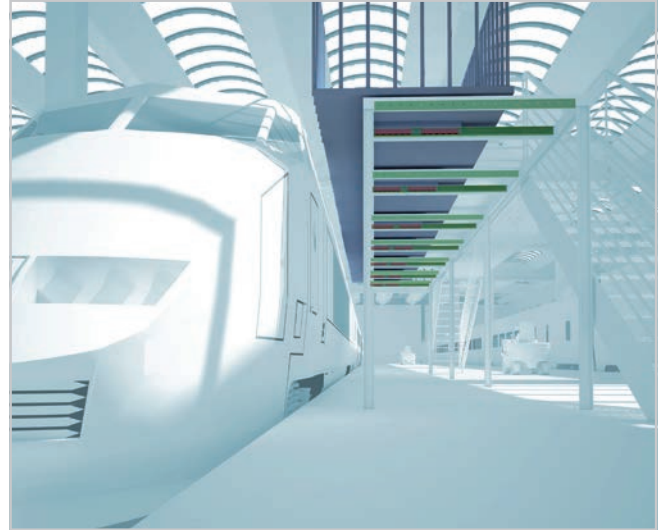
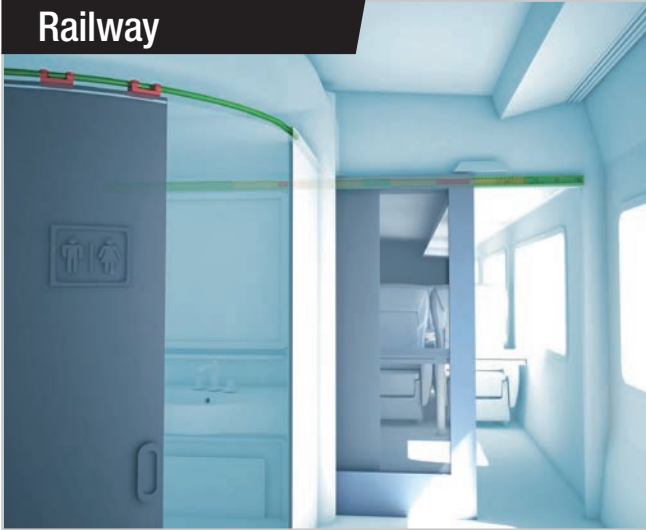

**Medical**

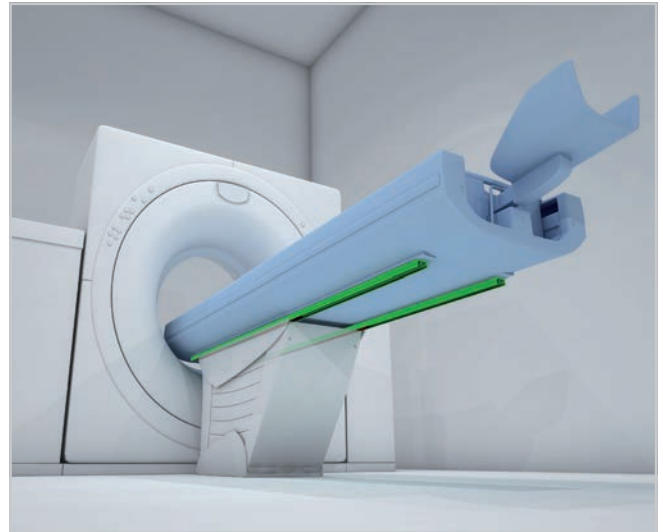
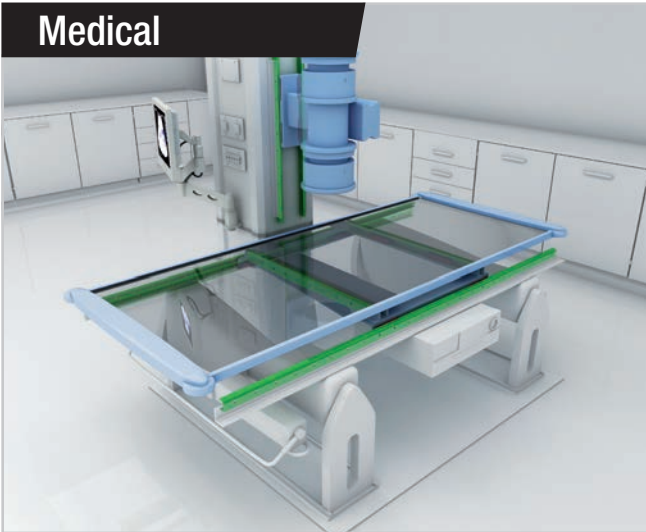

**Logistics**

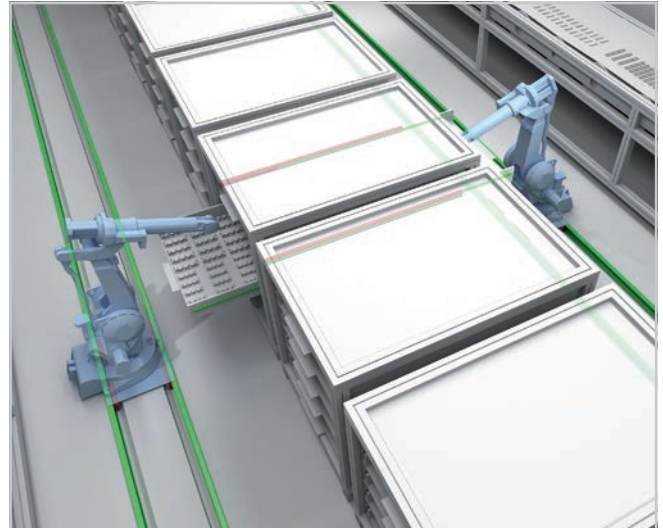
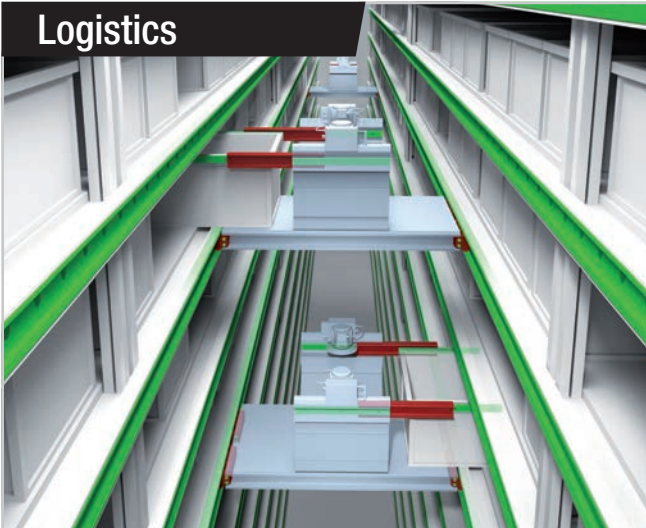



## Aerospace

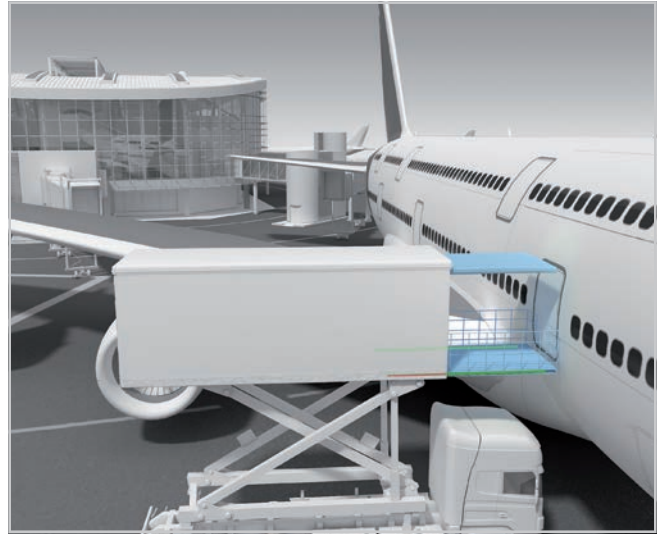

## Special Vehicles

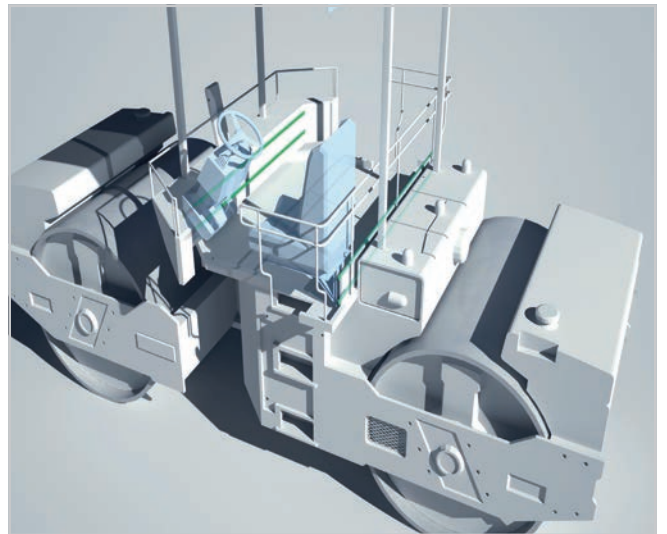

## Industrial

