



PACIFIC INTERNATIONAL BEARING SALES, INC.
800.228.8895 • WWW.PACIFICBEARINGSALES.COM

NB LINEAR SYSTEM

The NB linear system is a linear motion mechanism which utilizes the recirculating movement of ball or roller elements to provide smooth and accurate linear travel. NB offers a wide range of linear motion products that may contribute to the size and weight reduction of machinery and other equipment, while providing dependable performance in high-precision equipment.

ADVANTAGES

Low Friction and Excellent Response:

The dynamic friction of rolling ball or roller elements is substantially lower than that of full-face surface sliding friction. Since the difference between rolling dynamic and static friction is small, motion response is excellent and results in superior dependable movement. This also allows for easy fabrication of mechanisms requiring precise positioning or high-speed acceleration.

High Precision and Smooth Movement:

The NB linear system is designed for smooth rolling movements. The rolling element's raceway contact surface is finished through high-precision grinding. The recirculating movement of the rolling elements allow for continuous high-precision linear movement without clearance.

High Load Capacity and Long Travel Life:

Although the NB linear system is designed to be compact, the use of large rolling elements and machined raceway surface results in high load capacity and long travel life.

Ease of Installation:

The NB linear system shortens machining and assembly time when compared with that of a full face surface sliding bearing system.

Variety of Models:

A wide variety of models and types of NB systems are available for just about any shape or material option. This permits the selection of the best appropriate linear component for any application.





PROCESS FOR SELECTING NB LINEAR SYSTEM

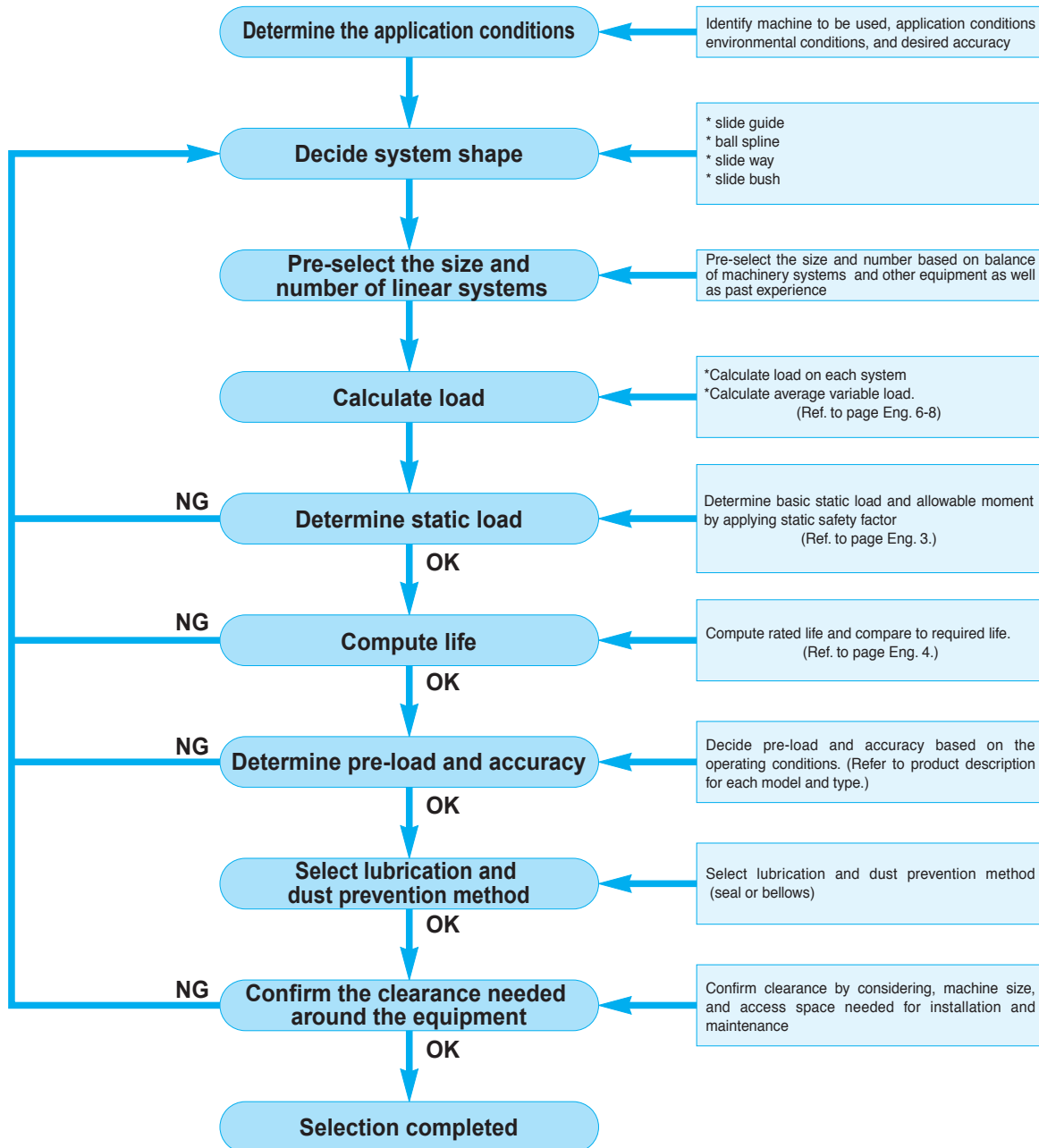

ALLOWABLE LOAD

Load and Moment:

A load may be exerted to a linear system as depicted in Figure 1-1. In addition, a moment may be applied to a slide guide. Each type of load addressed by NB is described as follows.

Basic Static Load Rating(Compliant with ISO14728-2") and Allowable Static Moment:

Under excess or impact load conditions applied to a linear system while it is stationary or moving slowly, a permanent deformation occurs on either the rolling surface or the rolling elements. When this deformation exceeds a predictable level, it becomes a source of vibration and acoustic noise during operation and will also result in rough motion and shortens life. To prevent this permanent deformation and deterioration in movement accuracy, a basic static load rating (Co) is given as an allowable load. This basic static load rating is defined as the static load that results in the maximum allowable stress at the center of the contact surface between the rolling elements and the rolling surface. The sum of the permanent deformation of the rolling elements and that of the rolling surface is 1/10,000 the diameter of the rolling elements. In linear systems, a moment may also be present when applied in addition to the static load. The allowable static moment is defined by M_P , M_Y , and M_R , which are illustrated in Figure 1-1.

*1: This does not apply to some products.

Allowable Load and Static Safety Factor:

The basic static load rating and allowable static moment define the maximum static load in each direction. These maximum static loads are not necessarily applicable depending on the operating conditions, the mounting accuracy, and the required motion accuracy. Therefore, an allowable load with a safety factor that covers these factors must be obtained. In general, the minimum static safety factor is based on the values as listed in Table 1-1.

Allowable load
 $P_{max.} \leq C_o / f_s \dots\dots\dots(1)$
 Allowable moment
 $M_{max.} \leq (M_P, M_Y, M_R) / f_s \dots\dots\dots(2)$

f_s : static safety factor C_o : basic static load rating(N)
 $P_{max.}$: allowable load(N) M_P, M_R, M_Y : allowable static moment(N·m)
 $M_{max.}$: allowable moment(N·m)

Figure 1-1 Load and Moment

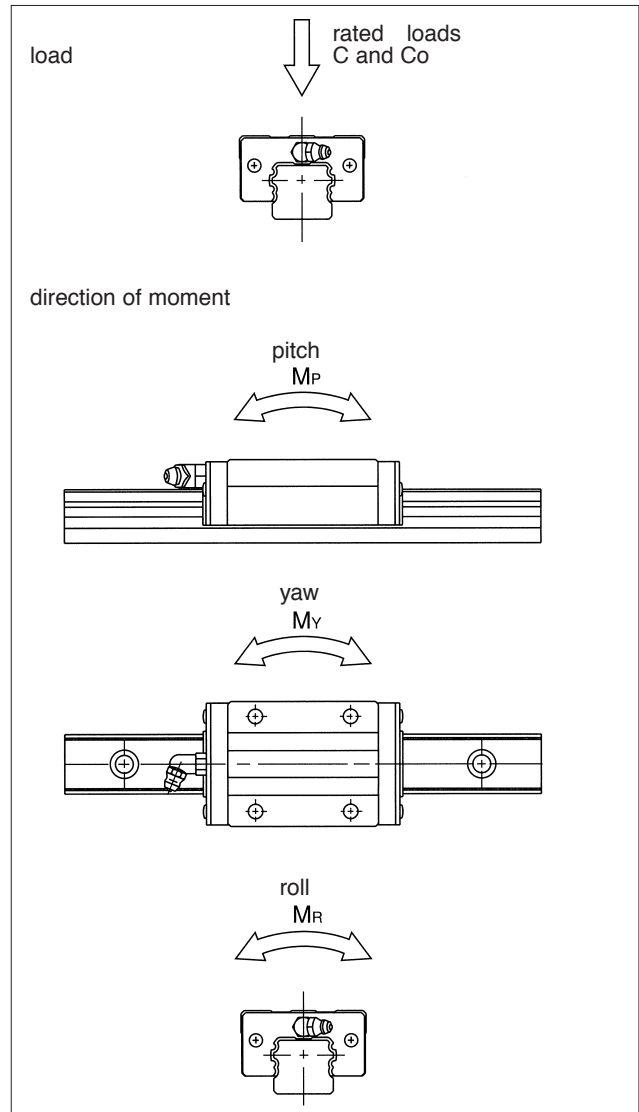

Table 1-1 Minimum Static Safety Factor

operating conditions	static safety factor
normal	1 ~ 2
smooth motion required	2 ~ 4
vibration/impact loading	3 ~ 5



LIFE

Life of a Linear System:

If a linear system reciprocates when it is under a load, a continuous stress acts on it, ultimately causing flaking of its rolling elements and/or rolling surfaces due to material fatigue, making it inoperable. The distance a linear system travels before this flaking condition first occurs is called the life of the system. A linear system can also become inoperable due to sintering, cracking, pitting, or rusting. These factors are differentiated from those affecting the life because they are related to installation accuracy, operating environment, or the selected lubrication method of the installer.

Rated Life:

Even when two linear systems are manufactured at the same time, have the same part number, and are used under identical conditions, their lifetimes can differ due to differences in their fatigue failure characteristics. This prevents determining the life of any particular linear system. Therefore, the rated life is determined statistically and is defined as the distance 90% of linear systems travel before experiencing flaking.

Rated Basic Dynamic Load (compliant with ISO14728-1²) and Rated Basic Dynamic Torque:

The life of a linear system is expressed in terms of the distance traveled. Therefore, the life of a linear system is calculated using the allowable load that corresponds to a certain distance traveled. This allowable load is a measure of the system's performance relative to the applied load and is called the rated basic dynamic load. It is defined as a constant-direction load with a magnitude corresponding to a life of 50x10³ m. In some cases or linear systems, the basic dynamic load rating may vary depending on the direction of the applied force. In the NB Linear System catalog, the value of the basic dynamic load rating is assumed when a force is applied from directly above and is indicated in the dimension tables. For ball splines, the linear motion may involve torque loading, so the basic dynamic torque rating is defined in a similar fashion.

^{*2}: This does not apply to some products.

Rated Life Estimation:

The rated lifetime estimation depends on the type of rolling element used. Both Equations (3) and (4) are used for ball and roller elements respectively. In cases when torque loading is applied, Equation (5) is to be used.

When a ball is used as the rolling element,

$$L = \left(\frac{C}{P} \right)^3 \cdot 50 \dots\dots\dots(3)$$

When a roller is used as the rolling element,

$$L = \left(\frac{C}{P} \right)^{10/3} \cdot 50 \dots\dots\dots(4)$$

When torque loading is applied,

$$L = \left(\frac{C_T}{T} \right)^3 \cdot 50 \dots\dots\dots(5)$$

L : rated life(km) C : basic dynamic load rating(N)
P : applied load(N) C_T : basic dynamic torque rating(N·m)
T : applied torque(N·m)

Numerous variables, such as guide rail accuracy, mounting conditions, operating conditions, vibration and shock while under linear motion affect an actual application. Therefore, calculating the actual applied load accurately is extremely difficult. In general, the calculation is simplified by using coefficients representing these effects. These coefficients include hardness (f_H), temperature (f_T), contact (f_C), and applied load (f_w). By using these coefficients, Equations (3) ~ (5) can be expressed by Equations (6) ~ (8).

When a ball is used as the rolling element,

$$L = \left(\frac{f_H \cdot f_T \cdot f_C \cdot C}{f_w \cdot P} \right)^3 \cdot 50 \dots\dots\dots(6)$$

When a roller is used as the rolling element,

$$L = \left(\frac{f_H \cdot f_T \cdot f_C \cdot C}{f_w \cdot P} \right)^{10/3} \cdot 50 \dots\dots\dots(7)$$

When torque loading is applied,

$$L = \left(\frac{f_H \cdot f_T \cdot f_C \cdot C_T}{f_w \cdot T} \right)^3 \cdot 50 \dots\dots\dots(8)$$

L : rated life(km) f_H : hardness coefficient
f_C : contact coefficient f_w : applied load coefficient
P : applied load(N) C : basic dynamic load rating (N)
C_T : basic dynamic torque rating(N·m) T : applied torque(N·m)



If the distance traveled per unit time is known, the life can be expressed in terms of time, which may be easier to understand. The relationship between the stroke distance, the stroke frequency per minute, and the life time is expressed by Equation (9)

Hardness Coefficient (f_H):

In a linear system, the guide rail serves the same purpose as an inner race of a ball bearing. Therefore, the hardness of the guide rail plays an important role in determining the rated load. If the surface hardness is less than HRC58, the rated load is reduced. NB uses an advanced heat treatment method to maintain an appropriate level of hardness. However, if guide rails with inadequate hardness must be used, the rated load must be re-calibrated based on the hardness coefficients given in Figure 1-2.

Temperature Coefficient (f_T):

NB linear systems are heat treated to reduce the amount of wear. Therefore, if the operating temperature exceeds 100 °C, hardness is reduced and the life of the system is shortened. The variation in hardness with temperature is shown in Figure 1-3.

Contact Coefficient (f_c):

When two or more linear systems are used in contact with each other, the variation in each system and the accuracy of the mounting surfaces must be taken into consideration. In general, the coefficient values given in Table 1-2 should be used to compute the life.

Applied Load Coefficient (f_w):

When computing the applied load, the weight of the mass, inertial force, moment resulting from the motion, and the variation with time should be accurately estimated. However, it is very difficult to accurately estimate the applied load due to the existence of numerous variables, including the start/stop conditions of the reciprocating motion and of the shock/vibration. Estimation is simplified by using the values given in Table 1-3.

$$L_h = \frac{L \cdot 10^3}{2 \cdot \ell \cdot s \cdot n1 \cdot 60} \dots\dots\dots (9)$$

L_h : life time(hr) ℓ s : stroke distance(m)
n1 : stroke frequency per min.(cpm)

Figure 1-2 Hardness Coefficient

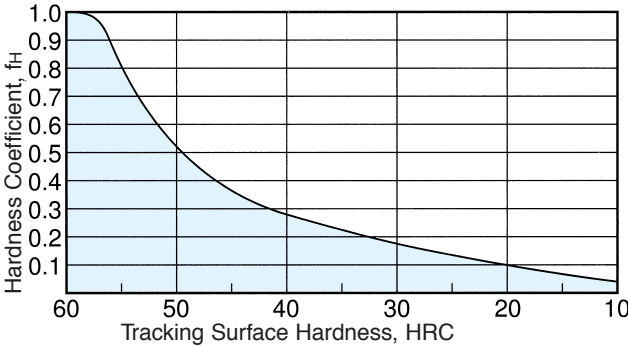

Figure 1-3 Temperature Coefficient

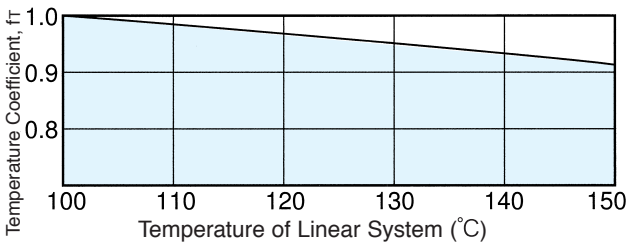

Table 1-2 Contact Coefficient

number of linear systems in contact and applied to a single shaft	contact coefficient f _c
1	1.00
2	0.81
3	0.72
4	0.66
5	0.61

Table 1-3 Applied Load Coefficient

operating condition		applied load coefficient, f _w
loading condition	velocity	
no shock/vibration	15 m/min or less	1.0~1.5
low shock/vibration	60 m/min or less	1.5~2.0
high shock/vibration	60 m/min or more	2.0~3.5



Method for Determining Applied Load:

Typical cases that linear systems are set and the equations for determining the applied load for each case example are summarized in Table 1-4 and 1-5.

W : applied load (N) P₁ - P₄ : load applied to linear system (N) X, Y : linear system span (mm) x, y, ℓ : distance to load applied or to working center of gravity (mm) g : gravitational acceleration (9.8 x 10³ mm/s²) V : velocity (mm/s) t₁ : duration of acceleration (sec) t₃ : duration of deceleration (sec)

Table 1-4 Method for Determining Applied Load (1)

	condition	applied load computation formula
under static conditions or constant velocity motion	2 horizontal axes  	$P_1 = \frac{1}{4} W + \frac{X_0}{2X} W + \frac{Y_0}{2Y} W$ $P_2 = \frac{1}{4} W - \frac{X_0}{2X} W + \frac{Y_0}{2Y} W$ $P_3 = \frac{1}{4} W + \frac{X_0}{2X} W - \frac{Y_0}{2Y} W$ $P_4 = \frac{1}{4} W - \frac{X_0}{2X} W - \frac{Y_0}{2Y} W$ <p>Note: If the calculation results in a negative value, the loading direction is in the opposite direction, but with the same computed magnitude.</p>
	2 horizontal axes, over-hang  	
	2 horizontal axes moving rails  	

Table 1-5 Method for Determining Applied Load (2)

	condition	applied load computation formula
under static conditions or constant velocity motion	<p>2 vertical/side axes</p>	$P_1=P_2=P_3=P_4=\frac{l_1}{2Y} W$ $P_{1S}=P_{3S}=\frac{1}{4} W + \frac{X_0}{2X} W$ $P_{2S}=P_{4S}=\frac{1}{4} W - \frac{X_0}{2X} W$
	<p>2 vertical axes</p>	$P_1=P_2=P_3=P_4=\frac{l_1}{2X} W$ $P_{1S}=P_{2S}=P_{3S}=P_{4S}=\frac{l_2}{2X} W$
under constant acceleration conditions	<p>2 horizontal axes</p>	<p>under acceleration</p> $P_1=P_3=\frac{1}{4} W \left(1 + \frac{2V_1 l_1}{gt_1 X} \right)$ $P_2=P_4=\frac{1}{4} W \left(1 - \frac{2V_1 l_1}{gt_1 X} \right)$ <p>under deceleration</p> $P_1=P_3=\frac{1}{4} W \left(1 - \frac{2V_1 l_1}{gt_3 X} \right)$ $P_2=P_4=\frac{1}{4} W \left(1 + \frac{2V_1 l_1}{gt_3 X} \right)$ <p>under constant velocity motion</p> $P_1=P_2=P_3=P_4=\frac{1}{4} W$ <p>※g:gravitational acceleration ($9.8 \times 10^3 \text{mm/sec}^2$)</p>

Equivalent Coefficient

The linear systems are generally used with two axes, each with several bearing elements attached. However, a bearing element or two in close contact may be attached to one axes when, for example, only limited mounting space is available. In such a case, multiply the moment equivalent coefficient shown in Tables 1-7 thru 1-21 by the applied moment load to calculate the load.

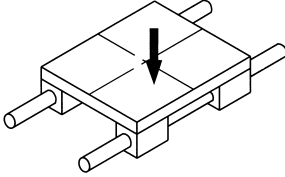
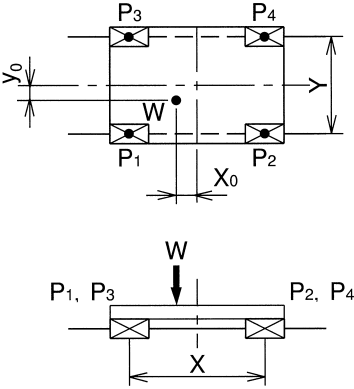
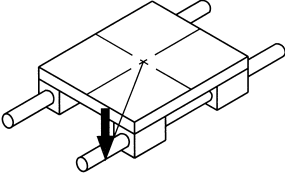
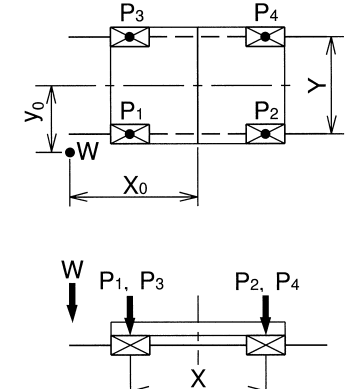
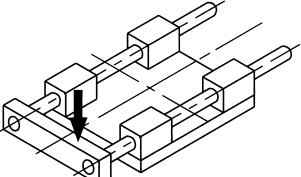
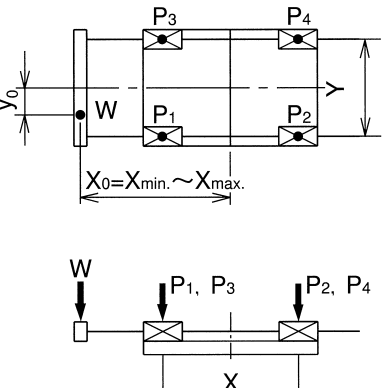
The following is a formula for calculating the equivalent load when a moment is applied to the linear system.

$$P = E \cdot M$$

P: moment equivalent load per bearing element (N)
E: moment equivalent coefficient M: applied moment (N · mm)



Method for Determining Applied Load (2)

Table 1-6 shows the formulas for determining the applied load for each case where moment is applied to the linear system.

W: applied load (N) P: load applied to the linear system (N) l : distance to the center of a bearing element (mm)

Table 1-6 Method for Determining Applied Load (3)

	condition	applied load computation formula
1 axis application	1 horizontal axis, 1 bearing element 	$P = W + E_{p1} W l_1 + E_r W l_2$ Ep1: Mp equivalent coefficient with 1 bearing element used Er: Mr equivalent coefficient
	1 sideways axis, 1 bearing element 	$P = W + E_{y1} W l_1 + E_r W l_2$ Ey1: My equivalent coefficient with 1 bearing element used Er: Mr equivalent coefficient
	1 vertical axis, 1 bearing element 	$P = E_{p1} W l_1 + E_{y1} W l_2$ Ep1: Mp equivalent coefficient with 1 bearing element used Ey1: My equivalent coefficient with 1 block (outer cylinder) used
2 axes application	2 horizontal axes, 1 bearing element each 	$P = W/2 + W l_2/Y + E_{p1} W l_1/2$ Ep1: Mp equivalent coefficient with 1 bearing element used Y: span between the two axes centers
	2 sideways axes, 1 bearing element each 	$P = W/2 + E_{y1} W l_2/2 + W l_1/Y$ Ey1: My equivalent coefficient with 1 bearing element used Y: span between the two axes centers
	2 vertical axes, 1 bearing element each 	$P = E_{p1} W l_1/2 + E_{y1} W l_2/2$ Ep1: Mp equivalent coefficient with 1 bearing element used Ey1: My equivalent coefficient with 1 bearing element used



PACIFIC INTERNATIONAL BEARING SALES, INC.

800.228.8895 • WWW.PACIFICBEARINGSALES.COM

Table 1-7 Slide Guide SEB and SER Type (1)

part number	equivalent coefficient				
	Ep ₁	Ep ₂	Ey ₁	Ey ₂	Er
SEBS 5B	6.64 × 10 ⁻¹	9.61 × 10 ⁻²	7.91 × 10 ⁻¹	1.15 × 10 ⁻¹	3.85 × 10 ⁻¹
SEBS 5BY	5.17 × 10 ⁻¹	8.38 × 10 ⁻²	6.16 × 10 ⁻¹	9.99 × 10 ⁻²	3.85 × 10 ⁻¹
SEBS 7B	4.62 × 10 ⁻¹	6.65 × 10 ⁻²	5.50 × 10 ⁻¹	7.93 × 10 ⁻²	2.74 × 10 ⁻¹
SEBS 7BY	2.84 × 10 ⁻¹	5.00 × 10 ⁻²	3.38 × 10 ⁻¹	5.96 × 10 ⁻²	2.74 × 10 ⁻¹
SEBS 9B	3.26 × 10 ⁻¹	5.26 × 10 ⁻²	3.88 × 10 ⁻¹	6.27 × 10 ⁻²	2.15 × 10 ⁻¹
SEBS 9BY	2.26 × 10 ⁻¹	4.14 × 10 ⁻²	2.69 × 10 ⁻¹	4.94 × 10 ⁻²	2.15 × 10 ⁻¹
SEBS 12B	3.08 × 10 ⁻¹	4.71 × 10 ⁻²	3.67 × 10 ⁻¹	5.61 × 10 ⁻²	1.60 × 10 ⁻¹
SEBS 12BY	2.02 × 10 ⁻¹	3.64 × 10 ⁻²	2.41 × 10 ⁻¹	4.33 × 10 ⁻²	1.60 × 10 ⁻¹
SEBS 15B	2.31 × 10 ⁻¹	3.85 × 10 ⁻²	2.75 × 10 ⁻¹	4.58 × 10 ⁻²	1.29 × 10 ⁻¹
SEBS 15BY	1.52 × 10 ⁻¹	2.90 × 10 ⁻²	1.81 × 10 ⁻¹	3.45 × 10 ⁻²	1.29 × 10 ⁻¹
SEBS 20B	1.41 × 10 ⁻¹	2.47 × 10 ⁻²	1.68 × 10 ⁻¹	2.94 × 10 ⁻²	9.76 × 10 ⁻²
SEBS 20BY	1.01 × 10 ⁻¹	1.95 × 10 ⁻²	1.20 × 10 ⁻¹	2.32 × 10 ⁻²	9.76 × 10 ⁻²
SEBS 5WB	4.51 × 10 ⁻¹	7.70 × 10 ⁻²	5.37 × 10 ⁻¹	9.17 × 10 ⁻²	1.96 × 10 ⁻¹
SEBS 5WBY	3.25 × 10 ⁻¹	6.15 × 10 ⁻²	3.88 × 10 ⁻¹	7.33 × 10 ⁻²	1.96 × 10 ⁻¹
SEBS 7WB	3.26 × 10 ⁻¹	5.26 × 10 ⁻²	3.88 × 10 ⁻¹	6.27 × 10 ⁻²	1.40 × 10 ⁻¹
SEBS 7WBY	2.26 × 10 ⁻¹	4.14 × 10 ⁻²	2.69 × 10 ⁻¹	4.94 × 10 ⁻²	1.40 × 10 ⁻¹
SEBS 9WB	2.41 × 10 ⁻¹	4.23 × 10 ⁻²	2.87 × 10 ⁻¹	5.04 × 10 ⁻²	1.08 × 10 ⁻¹
SEBS 9WBY	1.71 × 10 ⁻¹	3.31 × 10 ⁻²	2.03 × 10 ⁻¹	3.94 × 10 ⁻²	1.08 × 10 ⁻¹
SEBS 12WB	2.17 × 10 ⁻¹	3.81 × 10 ⁻²	2.59 × 10 ⁻¹	4.55 × 10 ⁻²	8.16 × 10 ⁻²
SEBS 12WBY	1.51 × 10 ⁻¹	2.94 × 10 ⁻²	1.79 × 10 ⁻¹	3.50 × 10 ⁻²	8.16 × 10 ⁻²
SEBS 15WB	1.63 × 10 ⁻¹	3.03 × 10 ⁻²	1.94 × 10 ⁻¹	3.61 × 10 ⁻²	4.71 × 10 ⁻²
SEBS 15WBY	1.13 × 10 ⁻¹	2.29 × 10 ⁻²	1.35 × 10 ⁻¹	2.73 × 10 ⁻²	4.71 × 10 ⁻²
SEBS 2A	7.06 × 10 ⁻¹	1.37 × 10 ⁻¹	5.92 × 10 ⁻¹	1.15 × 10 ⁻¹	9.09 × 10 ⁻¹
SEBS 3A	9.16 × 10 ⁻¹	1.49 × 10 ⁻¹	7.69 × 10 ⁻¹	1.25 × 10 ⁻¹	6.25 × 10 ⁻¹
SEBS 3AY	6.02 × 10 ⁻¹	1.13 × 10 ⁻¹	5.05 × 10 ⁻¹	9.48 × 10 ⁻²	6.25 × 10 ⁻¹
SEBS 5A	6.11 × 10 ⁻¹	1.01 × 10 ⁻¹	5.13 × 10 ⁻¹	8.46 × 10 ⁻²	3.85 × 10 ⁻¹
SEBS 5AY	4.65 × 10 ⁻¹	8.45 × 10 ⁻²	3.90 × 10 ⁻¹	7.09 × 10 ⁻²	3.85 × 10 ⁻¹
SEBS 7A	4.62 × 10 ⁻¹	7.48 × 10 ⁻²	3.87 × 10 ⁻¹	6.27 × 10 ⁻²	2.74 × 10 ⁻¹
SEBS 7AY	2.84 × 10 ⁻¹	5.49 × 10 ⁻²	2.38 × 10 ⁻¹	4.61 × 10 ⁻²	2.74 × 10 ⁻¹
SEB(S) 9A	3.32 × 10 ⁻¹	5.89 × 10 ⁻²	2.78 × 10 ⁻¹	4.94 × 10 ⁻²	2.20 × 10 ⁻¹
SEB(S) 9AY	2.25 × 10 ⁻¹	4.46 × 10 ⁻²	1.89 × 10 ⁻¹	3.74 × 10 ⁻²	2.20 × 10 ⁻¹
SEB(S) 12A	3.08 × 10 ⁻¹	5.62 × 10 ⁻²	2.58 × 10 ⁻¹	4.72 × 10 ⁻²	1.60 × 10 ⁻¹
SEB(S) 12AY	2.02 × 10 ⁻¹	4.11 × 10 ⁻²	1.70 × 10 ⁻¹	3.45 × 10 ⁻²	1.60 × 10 ⁻¹
SEB(S) 15A	2.31 × 10 ⁻¹	4.30 × 10 ⁻²	1.94 × 10 ⁻¹	3.61 × 10 ⁻²	1.29 × 10 ⁻¹
SEB(S) 15AY	1.52 × 10 ⁻¹	3.12 × 10 ⁻²	1.27 × 10 ⁻¹	2.62 × 10 ⁻²	1.29 × 10 ⁻¹
SEB(S) 20A	1.53 × 10 ⁻¹	3.03 × 10 ⁻²	1.28 × 10 ⁻¹	2.54 × 10 ⁻²	9.76 × 10 ⁻²
SEB(S) 20AY	1.01 × 10 ⁻¹	2.16 × 10 ⁻²	8.44 × 10 ⁻²	1.81 × 10 ⁻²	9.76 × 10 ⁻²
SEBS 3WA	6.74 × 10 ⁻¹	1.14 × 10 ⁻¹	5.42 × 10 ⁻¹	9.58 × 10 ⁻²	3.23 × 10 ⁻¹
SEBS 3WAY	4.48 × 10 ⁻¹	8.78 × 10 ⁻²	3.76 × 10 ⁻¹	7.37 × 10 ⁻²	3.23 × 10 ⁻¹
SEBS 7WA(D)	3.26 × 10 ⁻¹	5.56 × 10 ⁻²	2.73 × 10 ⁻¹	4.67 × 10 ⁻²	1.40 × 10 ⁻¹
SEBS 7WAY	2.26 × 10 ⁻¹	4.32 × 10 ⁻²	1.90 × 10 ⁻¹	3.63 × 10 ⁻²	1.40 × 10 ⁻¹
SEB(S) 9WA(D)	2.41 × 10 ⁻¹	4.72 × 10 ⁻²	2.02 × 10 ⁻¹	3.96 × 10 ⁻²	1.08 × 10 ⁻¹
SEB(S) 9WAY	1.71 × 10 ⁻¹	3.58 × 10 ⁻²	1.43 × 10 ⁻¹	3.00 × 10 ⁻²	1.08 × 10 ⁻¹
SEB(S) 12WA	2.02 × 10 ⁻¹	4.13 × 10 ⁻²	1.70 × 10 ⁻¹	3.46 × 10 ⁻²	8.16 × 10 ⁻²
SEB(S) 12WAY	1.43 × 10 ⁻¹	3.10 × 10 ⁻²	1.20 × 10 ⁻¹	2.60 × 10 ⁻²	8.16 × 10 ⁻²



Table 1-8 Slide Guide SEB and SER Type (2)

part number	equivalent coefficient				
	Ep ₁	Ep ₂	Ey ₁	Ey ₂	Er
SEB(S) 15WA	1.63 × 10 ⁻¹	3.29 × 10 ⁻²	1.37 × 10 ⁻¹	2.76 × 10 ⁻²	4.71 × 10 ⁻²
SEB(S) 15WAY	1.13 × 10 ⁻¹	2.43 × 10 ⁻²	9.48 × 10 ⁻²	2.04 × 10 ⁻²	4.71 × 10 ⁻²
SER(S) 9A	2.49 × 10 ⁻¹	4.15 × 10 ⁻²	2.15 × 10 ⁻¹	3.58 × 10 ⁻²	1.50 × 10 ⁻¹
SER(S) 12A	2.50 × 10 ⁻¹	4.16 × 10 ⁻²	2.23 × 10 ⁻¹	3.71 × 10 ⁻²	1.33 × 10 ⁻¹
SER(S) 15A	1.99 × 10 ⁻¹	3.32 × 10 ⁻²	1.79 × 10 ⁻¹	2.98 × 10 ⁻²	1.05 × 10 ⁻¹
SER(S) 20A	1.66 × 10 ⁻¹	2.77 × 10 ⁻²	1.47 × 10 ⁻¹	2.45 × 10 ⁻²	6.49 × 10 ⁻²
SER(S) 9WA	1.52 × 10 ⁻¹	2.53 × 10 ⁻²	1.36 × 10 ⁻¹	2.26 × 10 ⁻²	7.17 × 10 ⁻²
SER(S) 12WA	1.42 × 10 ⁻¹	2.36 × 10 ⁻²	1.28 × 10 ⁻¹	2.13 × 10 ⁻²	5.86 × 10 ⁻²
SER(S) 15WA	1.60 × 10 ⁻¹	2.66 × 10 ⁻²	1.45 × 10 ⁻¹	2.41 × 10 ⁻²	4.15 × 10 ⁻²

Ep₁: Mp equivalent coefficient with 1 block used Ep₂: Mp equivalent coefficient with 2 blocks used
 Ey₁: My equivalent coefficient with 1 block used Ey₂: My equivalent coefficient with 2 blocks used
 Er: Mr equivalent coefficient

Table 1-9 Slide Guide GL, SGL, and SGW Type

part number	equivalent coefficient				
	Ep ₁	Ep ₂	Ey ₁	Ey ₂	Er
GL15F(E)	2.57 × 10 ⁻¹	3.75 × 10 ⁻²	2.57 × 10 ⁻¹	3.75 × 10 ⁻²	1.28 × 10 ⁻¹
GL20F(E)	2.06 × 10 ⁻¹	3.31 × 10 ⁻²	2.06 × 10 ⁻¹	3.31 × 10 ⁻²	9.29 × 10 ⁻²
GL25F(E)	1.72 × 10 ⁻¹	2.82 × 10 ⁻²	1.72 × 10 ⁻¹	2.82 × 10 ⁻²	8.31 × 10 ⁻²
GL30F(E)	1.47 × 10 ⁻¹	2.27 × 10 ⁻²	1.47 × 10 ⁻¹	2.27 × 10 ⁻²	6.88 × 10 ⁻²
GL35F(E)	1.29 × 10 ⁻¹	2.02 × 10 ⁻²	1.29 × 10 ⁻¹	2.02 × 10 ⁻²	5.46 × 10 ⁻²
GL15TF(TE,HTF,HTE)	1.63 × 10 ⁻¹	2.87 × 10 ⁻²	1.63 × 10 ⁻¹	2.87 × 10 ⁻²	1.28 × 10 ⁻¹
GL20TF(TE)	1.41 × 10 ⁻¹	2.59 × 10 ⁻²	1.41 × 10 ⁻¹	2.59 × 10 ⁻²	9.29 × 10 ⁻²
GL25TF(TE,HTF,HTE)	1.09 × 10 ⁻¹	2.08 × 10 ⁻²	1.09 × 10 ⁻¹	2.08 × 10 ⁻²	8.31 × 10 ⁻²
GL30TF(TE,HTF,HTE)	9.31 × 10 ⁻²	1.71 × 10 ⁻²	9.31 × 10 ⁻²	1.71 × 10 ⁻²	6.88 × 10 ⁻²
GL35TF(TE,HTF,HTE)	8.15 × 10 ⁻²	1.51 × 10 ⁻²	8.15 × 10 ⁻²	1.51 × 10 ⁻²	5.46 × 10 ⁻²
GL20HTF(HTE)	1.21 × 10 ⁻¹	2.33 × 10 ⁻²	1.21 × 10 ⁻¹	2.33 × 10 ⁻²	9.29 × 10 ⁻²
GL45HTF(HTE)	6.52 × 10 ⁻²	1.23 × 10 ⁻²	6.52 × 10 ⁻²	1.23 × 10 ⁻²	4.38 × 10 ⁻²
SGL15F(E)	2.57 × 10 ⁻¹	3.75 × 10 ⁻²	2.57 × 10 ⁻¹	3.75 × 10 ⁻²	1.28 × 10 ⁻¹
SGL20F(E)	2.06 × 10 ⁻¹	3.31 × 10 ⁻²	2.06 × 10 ⁻¹	3.31 × 10 ⁻²	9.29 × 10 ⁻²
SGL25F(E)	1.72 × 10 ⁻¹	2.82 × 10 ⁻²	1.72 × 10 ⁻¹	2.82 × 10 ⁻²	8.31 × 10 ⁻²
SGL30F(E)	1.47 × 10 ⁻¹	2.27 × 10 ⁻²	1.47 × 10 ⁻¹	2.27 × 10 ⁻²	6.88 × 10 ⁻²
SGL35F(E)	1.29 × 10 ⁻¹	2.02 × 10 ⁻²	1.29 × 10 ⁻¹	2.02 × 10 ⁻²	5.46 × 10 ⁻²
SGL15TF(TE,HTF,HTE)	1.63 × 10 ⁻¹	2.87 × 10 ⁻²	1.63 × 10 ⁻¹	2.87 × 10 ⁻²	1.28 × 10 ⁻¹
SGL20TF(TE)	1.41 × 10 ⁻¹	2.59 × 10 ⁻²	1.41 × 10 ⁻¹	2.59 × 10 ⁻²	9.29 × 10 ⁻²
SGL25TF(TE,HTF,HTE)	1.09 × 10 ⁻¹	2.08 × 10 ⁻²	1.09 × 10 ⁻¹	2.08 × 10 ⁻²	8.31 × 10 ⁻²
SGL30TF(TE,HTF,HTE)	9.31 × 10 ⁻²	1.71 × 10 ⁻²	9.31 × 10 ⁻²	1.71 × 10 ⁻²	6.88 × 10 ⁻²
SGL35TF(TE,HTF,HTE)	8.15 × 10 ⁻²	1.51 × 10 ⁻²	8.15 × 10 ⁻²	1.51 × 10 ⁻²	5.46 × 10 ⁻²
SGL20HTF(HTE)	1.21 × 10 ⁻¹	2.33 × 10 ⁻²	1.21 × 10 ⁻¹	2.33 × 10 ⁻²	9.29 × 10 ⁻²
SGL45HTF(HTE)	6.52 × 10 ⁻²	1.23 × 10 ⁻²	6.52 × 10 ⁻²	1.23 × 10 ⁻²	4.38 × 10 ⁻²
SGW17TE	2.00 × 10 ⁻¹	3.27 × 10 ⁻²	2.00 × 10 ⁻¹	3.27 × 10 ⁻²	5.34 × 10 ⁻²
SGW21TE	1.68 × 10 ⁻¹	2.90 × 10 ⁻²	1.68 × 10 ⁻¹	2.90 × 10 ⁻²	4.80 × 10 ⁻²
SGW27TE	1.26 × 10 ⁻¹	2.32 × 10 ⁻²	1.26 × 10 ⁻¹	2.32 × 10 ⁻²	4.35 × 10 ⁻²
SGW35TE	8.39 × 10 ⁻²	1.56 × 10 ⁻²	8.39 × 10 ⁻²	1.56 × 10 ⁻²	2.62 × 10 ⁻²

Ep₁: Mp equivalent coefficient with 1 block used Ep₂: Mp equivalent coefficient with 2 blocks used
 Ey₁: My equivalent coefficient with 1 block used Ey₂: My equivalent coefficient with 2 blocks used
 Er: Mr equivalent coefficient



Table 1-10 Ball Spline

part number	equivalent coefficient	
	E ₁	E ₂
SSP 4	6.19×10^{-1}	1.18×10^{-1}
SSP 6	4.47×10^{-1}	5.70×10^{-2}
SSP 8	3.88×10^{-1}	5.74×10^{-2}
SSP 10	2.82×10^{-1}	4.37×10^{-2}
SSP 13A	3.57×10^{-1}	4.49×10^{-2}
SSP 16A	2.43×10^{-1}	3.75×10^{-2}
SSP 20A	1.48×10^{-1}	2.91×10^{-2}
SSP 20	1.79×10^{-1}	2.26×10^{-2}
SSP 25A	1.37×10^{-1}	2.27×10^{-2}
SSP 25	1.55×10^{-1}	1.94×10^{-2}
SSP 30	1.28×10^{-1}	1.58×10^{-2}
SSP 40	1.05×10^{-1}	1.28×10^{-2}
SSP 50	1.07×10^{-1}	1.69×10^{-2}
SSP 60	9.77×10^{-2}	1.44×10^{-2}
SSP 80	6.70×10^{-2}	1.21×10^{-2}
SSP 80L	4.56×10^{-2}	9.53×10^{-3}
SSP 100	5.92×10^{-2}	1.03×10^{-2}
SSP 100L	4.06×10^{-2}	7.90×10^{-3}
SPA 6W	1.14×10^{-1}	—
SPA 8W	1.16×10^{-1}	—
SPA 10W	8.74×10^{-2}	—

E₁: equivalent coefficient with 1 nut used
E₂: equivalent coefficient with 2 nuts used

Table 1-11 Slide Bush GM Type

part number	equivalent coefficient	
	E ₁	E ₂
GM 6	6.43×10^{-1}	1.07×10^{-1}
GM 8	4.92×10^{-1}	8.20×10^{-2}
GM 10	4.21×10^{-1}	7.01×10^{-2}
GM 12	3.85×10^{-1}	6.41×10^{-2}
GM 13	3.77×10^{-1}	6.29×10^{-2}
GM 16	3.25×10^{-1}	5.42×10^{-2}
GM 20	2.74×10^{-1}	4.57×10^{-2}
GM 25	1.98×10^{-1}	3.30×10^{-2}
GM 30	1.81×10^{-1}	3.02×10^{-2}
GM 6W	3.53×10^{-1}	—
GM 8W	2.38×10^{-1}	—
GM 10W	2.20×10^{-1}	—
GM 12W	2.07×10^{-1}	—
GM 13W	1.94×10^{-1}	—
GM 16W	1.70×10^{-1}	—
GM 20W	1.37×10^{-1}	—
GM 25W	9.02×10^{-2}	—
GM 30W	9.55×10^{-2}	—

E₁: equivalent coefficient with 1 bush used
E₂: equivalent coefficient with 2 bushes used

Table 1-12 Slide Bush SM Type

part number	equivalent coefficient	
	E ₁	E ₂
SM 3	1.24	2.13×10^{-1}
SM 4	1.21	1.78×10^{-1}
SM 5	8.96×10^{-1}	1.40×10^{-1}
SM 6	7.29×10^{-1}	1.09×10^{-1}
SM 8s	7.19×10^{-1}	1.20×10^{-1}
SM 8	5.46×10^{-1}	8.42×10^{-2}
SM 10	4.55×10^{-1}	7.02×10^{-2}
SM 12	4.32×10^{-1}	6.64×10^{-2}
SM 13	4.06×10^{-1}	6.21×10^{-2}
SM 16	3.59×10^{-1}	5.46×10^{-2}
SM 20	3.07×10^{-1}	4.70×10^{-2}
SM 25	2.17×10^{-1}	3.33×10^{-2}
SM 30	1.99×10^{-1}	3.07×10^{-2}
SM 35	1.71×10^{-1}	2.70×10^{-2}
SM 40	1.64×10^{-1}	2.51×10^{-2}
SM 50	1.20×10^{-1}	1.89×10^{-2}
SM 60	1.13×10^{-1}	1.75×10^{-2}
SM 80	8.18×10^{-2}	1.36×10^{-2}
SM 100	6.66×10^{-2}	1.11×10^{-2}
SM 120	5.63×10^{-2}	9.38×10^{-3}
SM 150	4.62×10^{-2}	7.71×10^{-3}
SM 3W	4.12×10^{-1}	—
SM 4W	4.03×10^{-1}	—
SM 5W	2.99×10^{-1}	—
SM 6W	2.43×10^{-1}	—
SM 8W	1.82×10^{-1}	—
SM 10W	1.52×10^{-1}	—
SM 12W	1.44×10^{-1}	—
SM 13W	1.35×10^{-1}	—
SM 16W	1.19×10^{-1}	—
SM 20W	1.02×10^{-1}	—
SM 25W	7.24×10^{-2}	—
SM 30W	6.63×10^{-2}	—
SM 35W	5.70×10^{-2}	—
SM 40W	5.47×10^{-2}	—
SM 50W	4.01×10^{-2}	—
SM 60W	3.77×10^{-2}	—

E₁: equivalent coefficient with 1 bush used
E₂: equivalent coefficient with 2 bushes used



Table 1-13 Slide Bush TRF Type

part number	equivalent coefficient	
	E ₁	E ₂
TRF 6	6.46×10^{-2}	—
TRF 8	4.90×10^{-2}	—
TRF 10	4.07×10^{-2}	—
TRF 12	3.92×10^{-2}	—
TRF 13	3.66×10^{-2}	—
TRF 16	3.20×10^{-2}	—
TRF 20	2.80×10^{-2}	—
TRF 25	2.00×10^{-2}	—
TRF 30	1.85×10^{-2}	—
TRF 35	1.68×10^{-2}	—
TRF 40	1.45×10^{-2}	—
TRF 50	1.16×10^{-2}	—
TRF 60	1.11×10^{-2}	—

E₁: equivalent coefficient with 1 bush used
E₂: equivalent coefficient with 2 bushes used

Table 1-15 Slide Bush SW Type

part number	equivalent coefficient	
	E ₁	E ₂
SWS 2	8.90×10^{-1}	1.48×10^{-1}
SWS 3	8.01×10^{-1}	1.33×10^{-1}
SW 4	7.95×10^{-1}	1.05×10^{-1}
SW 6	6.98×10^{-1}	9.75×10^{-2}
SW 8	4.09×10^{-1}	6.23×10^{-2}
SW 10	3.54×10^{-1}	5.33×10^{-2}
SW 12	3.10×10^{-1}	4.76×10^{-2}
SW 16	2.29×10^{-1}	3.40×10^{-2}
SW 20	1.94×10^{-1}	3.01×10^{-2}
SW 24	1.69×10^{-1}	2.59×10^{-2}
SW 32	1.19×10^{-1}	1.87×10^{-2}
SW 40	9.23×10^{-2}	1.54×10^{-2}
SW 48	7.84×10^{-2}	1.31×10^{-2}
SW 64	5.47×10^{-2}	9.11×10^{-3}
SW 4W	2.65×10^{-1}	—
SW 6W	2.33×10^{-1}	—
SW 8W	1.37×10^{-1}	—
SW 10W	1.18×10^{-1}	—
SW 12W	1.03×10^{-1}	—
SW 16W	7.62×10^{-2}	—
SW 20W	6.47×10^{-2}	—
SW 24W	5.62×10^{-2}	—
SW 32W	3.98×10^{-2}	—

E₁: equivalent coefficient with 1 bush used
E₂: equivalent coefficient with 2 bushes used

Table 1-14 Slide Bush KB Type

part number	equivalent coefficient	
	E ₁	E ₂
KB 3	1.28	2.13×10^{-1}
KB 4	1.05	1.75×10^{-1}
KB 5	5.40×10^{-1}	9.00×10^{-2}
KB 8	5.61×10^{-1}	8.00×10^{-2}
KB 10	4.21×10^{-1}	7.02×10^{-2}
KB 12	4.02×10^{-1}	6.20×10^{-2}
KB 16	3.77×10^{-1}	5.73×10^{-2}
KB 20	3.29×10^{-1}	4.49×10^{-2}
KB 25	2.14×10^{-1}	3.37×10^{-2}
KB 30	2.08×10^{-1}	2.96×10^{-2}
KB 40	1.64×10^{-1}	2.51×10^{-2}
KB 50	1.20×10^{-1}	1.89×10^{-2}
KB 60	1.21×10^{-1}	1.55×10^{-2}
KB 80	7.34×10^{-2}	1.22×10^{-2}
KB 8W	1.87×10^{-1}	—
KB 12W	1.34×10^{-1}	—
KB 16W	1.25×10^{-1}	—
KB 20W	1.10×10^{-1}	—
KB 25W	7.14×10^{-2}	—
KB 30W	6.96×10^{-2}	—
KB 40W	5.47×10^{-2}	—
KB 50W	4.02×10^{-2}	—
KB 60W	4.11×10^{-2}	—

E₁: equivalent coefficient with 1 bush used
E₂: equivalent coefficient with 2 bushes used



Table 1-16 Slide Rotary Bush

part number	equivalent coefficient	
	E ₁	E ₂
SRE 6	6.83×10^{-1}	1.14×10^{-1}
SRE 8	4.98×10^{-1}	8.31×10^{-2}
SRE 10	4.12×10^{-1}	6.86×10^{-2}
SRE 12	4.19×10^{-1}	6.98×10^{-2}
SRE 13	3.93×10^{-1}	6.54×10^{-2}
SRE 16	3.40×10^{-1}	5.66×10^{-2}
SRE 20	2.90×10^{-1}	4.84×10^{-2}
SRE 25	1.98×10^{-1}	3.29×10^{-2}
SRE 30	1.80×10^{-1}	3.01×10^{-2}
RK 12	4.32×10^{-1}	6.64×10^{-2}
RK 16	3.59×10^{-1}	5.46×10^{-2}
RK 20	3.07×10^{-1}	4.70×10^{-2}
RK 25	2.17×10^{-1}	3.33×10^{-2}
RK 30	1.99×10^{-1}	3.07×10^{-2}

E₁: equivalent coefficient with 1 bush used
E₂: equivalent coefficient with 2 bushes used

Table 1-17 Slide Table NVT Type

part number	equivalent coefficient		
	Ep	Ey	Er
NVT3055	6.06×10^{-1}	2.37×10^{-1}	3.80×10^{-1}
NVT3080	9.90×10^{-2}	1.03×10^{-1}	9.02×10^{-2}
NVT3105	9.66×10^{-2}	8.92×10^{-2}	1.36×10^{-1}
NVT3130	8.78×10^{-2}	7.79×10^{-2}	1.49×10^{-1}
NVT3155	5.74×10^{-2}	5.67×10^{-2}	1.03×10^{-1}
NVT3180	5.36×10^{-2}	5.18×10^{-2}	1.11×10^{-1}
NVT3205	5.05×10^{-2}	4.78×10^{-2}	1.20×10^{-1}
NVT4085	1.04×10^{-1}	1.09×10^{-1}	6.28×10^{-2}
NVT4125	6.92×10^{-2}	6.97×10^{-2}	6.70×10^{-2}
NVT4165	6.50×10^{-2}	6.04×10^{-2}	8.87×10^{-2}
NVT4205	4.41×10^{-2}	4.41×10^{-2}	6.50×10^{-2}
NVT4245	4.15×10^{-2}	4.00×10^{-2}	7.79×10^{-2}
NVT6110	6.97×10^{-2}	7.45×10^{-2}	4.90×10^{-2}
NVT6160	6.01×10^{-2}	6.08×10^{-2}	5.66×10^{-2}
NVT6210	4.81×10^{-2}	4.74×10^{-2}	6.63×10^{-2}
NVT6260	4.21×10^{-2}	4.06×10^{-2}	6.84×10^{-2}
NVT6310	2.95×10^{-2}	2.98×10^{-2}	5.28×10^{-2}

Ep: Mp equivalent coefficient
Ey: My equivalent coefficient
Er: Mr equivalent coefficient



Table 1-18 Slide Table SVT Type (1)

part number	equivalent coefficient		
	Ep	Ey	Er
SVT1025	2.67×10^{-1}	3.25×10^{-1}	1.48×10^{-1}
SVT1035	3.10×10^{-1}	2.73×10^{-1}	1.48×10^{-1}
SVT1045	1.71×10^{-1}	1.87×10^{-1}	1.48×10^{-1}
SVT1055	1.51×10^{-1}	1.63×10^{-1}	1.48×10^{-1}
SVT1065	1.35×10^{-1}	1.44×10^{-1}	1.48×10^{-1}
SVT1075	1.11×10^{-1}	1.17×10^{-1}	1.48×10^{-1}
SVT1085	1.02×10^{-1}	1.07×10^{-1}	1.48×10^{-1}
SVT2035	1.67×10^{-1}	2.03×10^{-1}	1.11×10^{-1}
SVT2050	1.45×10^{-1}	1.64×10^{-1}	1.11×10^{-1}
SVT2065	1.22×10^{-1}	1.37×10^{-1}	1.11×10^{-1}
SVT2080	1.28×10^{-1}	1.19×10^{-1}	1.11×10^{-1}
SVT2095	1.10×10^{-1}	1.03×10^{-1}	1.11×10^{-1}
SVT2110	7.61×10^{-2}	8.08×10^{-2}	1.11×10^{-1}
SVT2125	6.94×10^{-2}	7.33×10^{-2}	1.11×10^{-1}
SVT2140	7.01×10^{-2}	6.73×10^{-2}	1.11×10^{-1}
SVT2155	6.43×10^{-2}	6.19×10^{-2}	1.11×10^{-1}
SVT2170	5.12×10^{-2}	5.33×10^{-2}	1.11×10^{-1}
SVT2185	4.81×10^{-2}	4.99×10^{-2}	1.11×10^{-1}
SVT3055	2.00×10^{-1}	1.75×10^{-1}	7.14×10^{-2}
SVT3080	1.22×10^{-1}	1.12×10^{-1}	7.14×10^{-2}
SVT3105	7.53×10^{-2}	8.14×10^{-2}	7.14×10^{-2}
SVT3130	6.08×10^{-2}	6.47×10^{-2}	7.14×10^{-2}
SVT3155	6.17×10^{-2}	5.89×10^{-2}	7.14×10^{-2}
SVT3180	5.15×10^{-2}	4.96×10^{-2}	7.14×10^{-2}
SVT3205	4.75×10^{-2}	4.59×10^{-2}	7.14×10^{-2}
SVT3230	3.85×10^{-2}	3.99×10^{-2}	7.14×10^{-2}
SVT3255	3.87×10^{-2}	3.76×10^{-2}	7.14×10^{-2}
SVT3280	3.64×10^{-2}	3.54×10^{-2}	7.14×10^{-2}

Ep: Mp equivalent coefficient
Ey: My equivalent coefficient
Er: Mr equivalent coefficient

Table 1-19 Slide Table SVT Type (2)

part number	equivalent coefficient		
	Ep	Ey	Er
SVT3305	3.09×10^{-2}	3.18×10^{-2}	7.14×10^{-2}
SVT4085	8.29×10^{-2}	9.38×10^{-2}	5.00×10^{-2}
SVT4125	6.11×10^{-2}	6.67×10^{-2}	5.00×10^{-2}
SVT4165	6.27×10^{-2}	5.88×10^{-2}	5.00×10^{-2}
SVT4205	4.89×10^{-2}	4.65×10^{-2}	5.00×10^{-2}
SVT4245	4.01×10^{-2}	3.85×10^{-2}	5.00×10^{-2}
SVT4285	3.39×10^{-2}	3.28×10^{-2}	5.00×10^{-2}
SVT4325	2.94×10^{-2}	2.86×10^{-2}	5.00×10^{-2}
SVT4365	2.60×10^{-2}	2.53×10^{-2}	5.00×10^{-2}
SVT4405	2.20×10^{-2}	2.27×10^{-2}	5.00×10^{-2}
SVT6110	6.83×10^{-2}	7.72×10^{-2}	4.44×10^{-2}
SVT6160	5.03×10^{-2}	5.49×10^{-2}	4.44×10^{-2}
SVT6210	3.97×10^{-2}	4.24×10^{-2}	4.44×10^{-2}
SVT6260	3.27×10^{-2}	3.45×10^{-2}	4.44×10^{-2}
SVT6310	2.78×10^{-2}	2.90×10^{-2}	4.44×10^{-2}
SVT6360	2.79×10^{-2}	2.70×10^{-2}	4.44×10^{-2}
SVT6410	2.42×10^{-2}	2.35×10^{-2}	4.44×10^{-2}
SVT6460	2.14×10^{-2}	2.08×10^{-2}	4.44×10^{-2}
SVT6510	1.92×10^{-2}	1.87×10^{-2}	4.44×10^{-2}
SVT9210	3.50×10^{-2}	3.90×10^{-2}	2.78×10^{-2}
SVT9310	3.14×10^{-2}	2.94×10^{-2}	2.78×10^{-2}
SVT9410	2.41×10^{-2}	2.57×10^{-2}	2.78×10^{-2}
SVT9510	1.98×10^{-2}	2.09×10^{-2}	2.78×10^{-2}
SVT9610	2.00×10^{-2}	1.92×10^{-2}	2.78×10^{-2}
SVT9710	1.70×10^{-2}	1.64×10^{-2}	2.78×10^{-2}
SVT9810	1.37×10^{-2}	1.42×10^{-2}	2.78×10^{-2}
SVT9910	1.22×10^{-2}	1.26×10^{-2}	2.78×10^{-2}
SVT91010	1.10×10^{-2}	1.13×10^{-2}	2.78×10^{-2}



PACIFIC INTERNATIONAL BEARING SALES, INC.

800.228.8895 • WWW.PACIFICBEARINGSALES.COM

Table 1-20 Slide Table SYT Type

part number	equivalent coefficient		
	Ep	Ey	Er
SYT1025	2.67×10^{-1}	3.25×10^{-1}	2.67×10^{-1}
SYT1035	3.10×10^{-1}	2.73×10^{-1}	2.67×10^{-1}
SYT1045	1.71×10^{-1}	1.87×10^{-1}	2.67×10^{-1}
SYT1055	1.51×10^{-1}	1.63×10^{-1}	2.67×10^{-1}
SYT1065	1.35×10^{-1}	1.44×10^{-1}	2.67×10^{-1}
SYT1075	1.11×10^{-1}	1.17×10^{-1}	2.67×10^{-1}
SYT1085	1.02×10^{-1}	1.07×10^{-1}	2.67×10^{-1}
SYT2035	1.67×10^{-1}	2.03×10^{-1}	1.54×10^{-1}
SYT2050	1.45×10^{-1}	1.64×10^{-1}	1.54×10^{-1}
SYT2065	1.22×10^{-1}	1.37×10^{-1}	1.54×10^{-1}
SYT2080	1.28×10^{-1}	1.19×10^{-1}	1.54×10^{-1}
SYT2095	1.10×10^{-1}	1.03×10^{-1}	1.54×10^{-1}
SYT2110	7.61×10^{-2}	8.08×10^{-2}	1.54×10^{-1}
SYT2125	6.94×10^{-2}	7.33×10^{-2}	1.54×10^{-1}
SYT3055	2.00×10^{-1}	1.75×10^{-1}	1.15×10^{-1}
SYT3080	1.22×10^{-1}	1.12×10^{-1}	1.15×10^{-1}
SYT3105	7.53×10^{-2}	8.14×10^{-2}	1.15×10^{-1}
SYT3130	6.08×10^{-2}	6.47×10^{-2}	1.15×10^{-1}
SYT3155	6.17×10^{-2}	5.89×10^{-2}	1.15×10^{-1}
SYT3180	5.15×10^{-2}	4.96×10^{-2}	1.15×10^{-1}
SYT3205	4.75×10^{-2}	4.59×10^{-2}	1.15×10^{-1}

Ep: Mp equivalent coefficient
 Ey: My equivalent coefficient
 Er: Mr equivalent coefficient

Table 1-21 Miniature Slide SYBS Type

part number	equivalent coefficient		
	Ep	Ey	Er
SYBS 6-13	8.35×10^{-1}	7.01×10^{-1}	8.51×10^{-1}
SYBS 6-21	5.45×10^{-1}	4.57×10^{-1}	8.51×10^{-1}
SYBS 8-11	8.82×10^{-1}	7.40×10^{-1}	5.88×10^{-1}
SYBS 8-21	4.81×10^{-1}	4.04×10^{-1}	5.88×10^{-1}
SYBS 8-31	3.57×10^{-1}	2.99×10^{-1}	5.88×10^{-1}
SYBS 12-23	4.31×10^{-1}	3.62×10^{-1}	3.13×10^{-1}
SYBS 12-31	3.57×10^{-1}	2.99×10^{-1}	3.13×10^{-1}
SYBS 12-46	2.35×10^{-1}	1.97×10^{-1}	3.13×10^{-1}

Ep: Mp equivalent coefficient
 Ey: My equivalent coefficient
 Er: Mr equivalent coefficient



Average Applied Load:

The load applied to a linear system generally varies with the distance traveled depending on how the system is used. This includes the start/stop processes of the reciprocating motion. The average applied load is used to compute the life corresponding to the actual application conditions.

1. When the load varies in a step manner with the distance traveled (Figure 1-4) and l_1 is the distance traveled under load P_1 , l_2 is the distance traveled under load P_2 , and l_n is the distance traveled under load P_n , the average applied load, P_m is obtained by the following equation

$$P_m = \sqrt[3]{\frac{1}{l}(P_1^3 l_1 + P_2^3 l_2 \dots + P_n^3 l_n)} \dots \dots (4)$$

P_m : average applied load (N)
 l : total distance traveled (m)

2. When the applied load varies linearly with the distance traveled (Figure 1-5), the average applied load, P_m is approximated by the following equation.

$$P_m \doteq \frac{1}{3}(P_{min} + 2P_{max}) \dots \dots \dots (5)$$

P_m : minimum applied load (N)
 P_{max} : maximum applied load (N)

3. When the applied load draws a sine-curve as shown by Figures 1-6 (a) and (b), the average applied load, P_m , is approximated by the following equations.

Figure 1-6(a) $P_m \doteq 0.65P_{max}$ (6)

Figure 1-6(b) $P_m \doteq 0.75P_{max}$ (7)

Figure 1-4 Applied Load Varies Stepwise

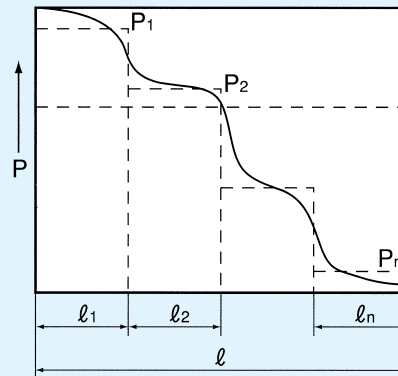

Figure 1-5 Applied Load Varies Linearly

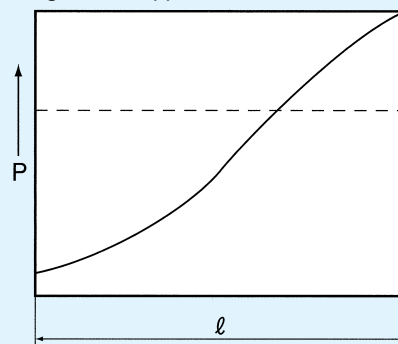
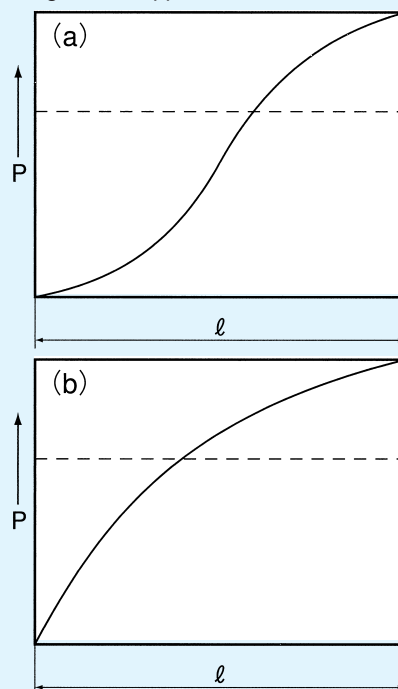

Figure 1-6 Applied Load Varies Sine-Curve



RIGIDITY AND PRE-LOAD

Effect of Pre-load and Rigidity:

The rigidity of a linear system must be taken into consideration when it is to be used in high-precision positioning devices or high-precision machinery. Pre-loaded slide guides and ball splines, which use a ball as the rolling element, are available upon request to meet the need for greater rigidity. If a force is applied to the ball elements without a pre-load, an elastic deformation proportional to the applied force to the 2/3 power will result.

$$\delta \propto W^{2/3} \dots\dots\dots(8)$$

δ : elastic deformation W : applied force

Therefore, the elastic deformation is relatively large during the initial loading stage, however then becomes smaller as the load increases.

The contact angles for all of the ball elements in SGL slide guides are the same as shown in Figure 1-7. Therefore, if the pre-load (P_1) applied results in an elastic deformation of δ_1 , the deformation will vary linearly with the applied load until the elastic deformation of the ball element on the other side cross the race becomes zero, as depicted in Figure 1-8. This permits the determination of the deformation of linear systems. The ratio between the applied load and the elastic deformation is defined as the rigidity of the system. Equation (9) can be used to determine the elastic deformation with an applied load of up to 2.8 times the pre-load.

$$2\delta_1 = 2kP_1^{2/3} = kP_2^{2/3} \dots\dots\dots(9)$$

$$P_2 = 2\sqrt[3]{2} \cdot P_1$$

k : constant P_1 : pre-load

P_2 : applied load when the pre-load becomes 0

Contact NB for further information on rigidity.

Types of Pre-Load and its Specification:

Pre-load is categorized into three primary ranges: normal, light, and medium. At NB, pre-load is applied by installing rolling elements that are slightly larger than normal. Therefore, the specification of the pre-load is expressed by a negative gap value.

Figure 1-7 Contact Structure of SGL Slide Guide

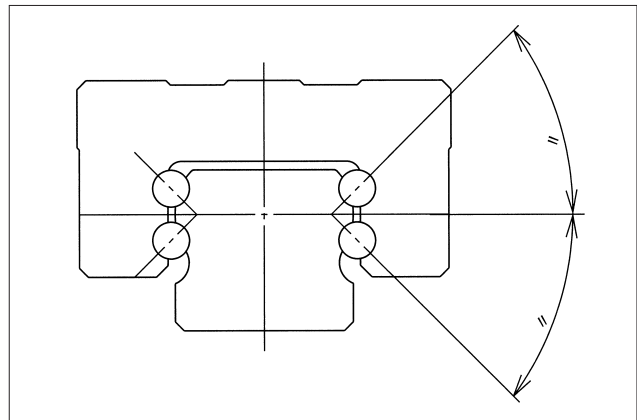
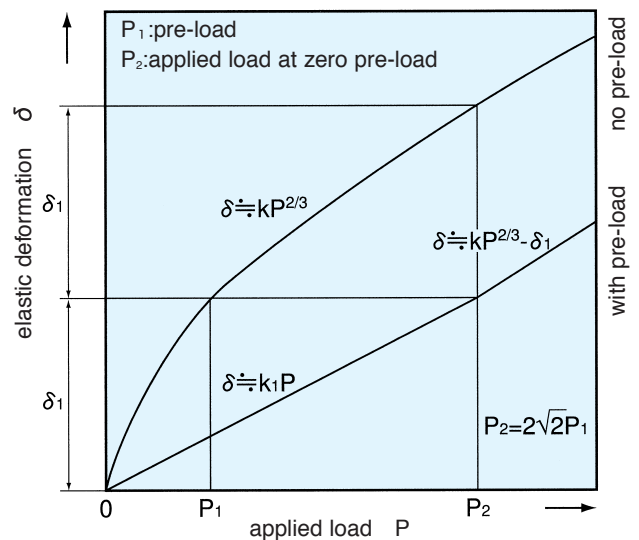

Figure 1-8 Applied Load vs. Elastic Deformation of Steel Balls





FRICITIONAL RESISTANCE AND REQUIRED THRUST

The static friction of a linear system is extremely low. Since the difference between the static and dynamic friction is marginal, stable motion can be achieved from low to high velocity. The frictional resistance (required thrust) can be obtained from the load and the seal resistance unique to each type of system using the following equation:

$$F = \mu \cdot W + f \dots\dots\dots(10)$$

F : frictional resistance(N) μ : dynamic frictional coefficient
W : applied load(N) f : seal resistance(N)

The dynamic friction coefficient varies with the applied load, pre-load, viscosity of the lubricant, and other factors. However, the values given in Table 1-22 are used for the normal loading condition (20% of basic dynamic load rating) without any pre-load. The seal resistance depends on the seal-lip condition as well as on the condition of the lubricant and does not change proportionally with the applied load, which commonly is expressed by a constant value of 2 to 5 N.

Table 1-22 Dynamic Friction Coefficient

type	major types	dynamic friction coefficient(μ)
slide guide	GL · SGL · SGW	0.002~0.003
	SEB	0.004~0.006
	SER	0.004~0.006
ball spline	SSP	0.004~0.006
rotary ball spline	SPR	0.004~0.006
slide bush	GM · SM	0.002~0.003
	KB · SW	
slide unit	SMA · SME	0.002~0.003
stroke bush	SR	0.0006~0.0012
slide rotary bush	RK	0.002~0.003
slide way	SV · SVW	0.001~0.003
slide table	SVT · SYT	0.001~0.003

Figure 1-9 Applied Load vs. Dynamic Friction Coefficient

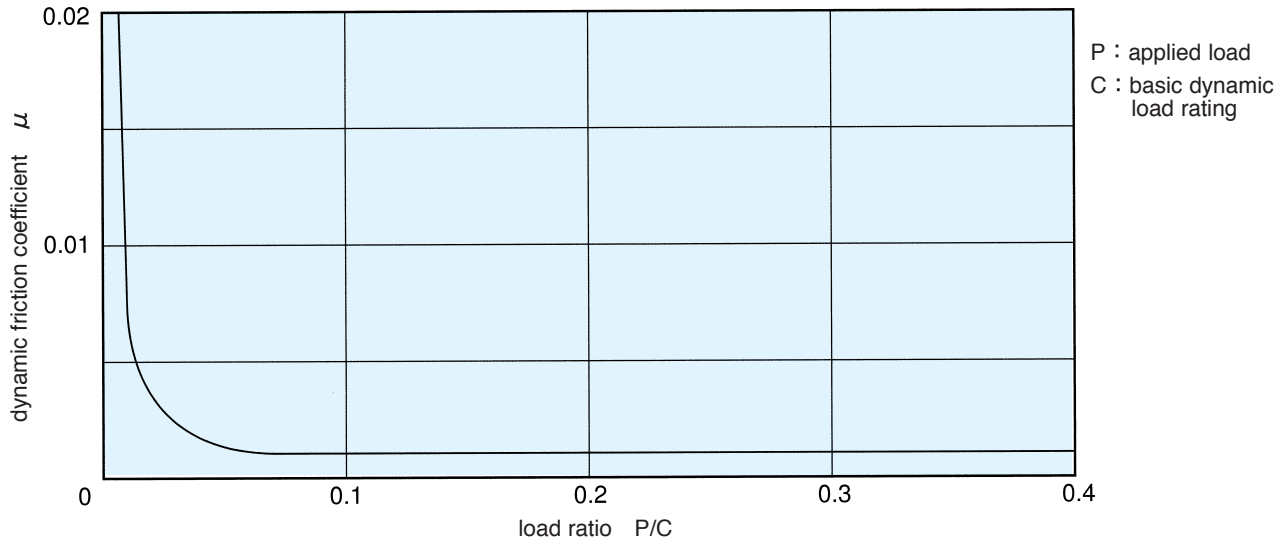



OPERATING ENVIRONMENT

Temperature Range:

NB linear systems are heat-treated in order to harden the surface. Because of this, if the temperature of the system exceeds 100°C, the hardness and rated load will be reduced (refer to page Eng. 5, hardness coefficient). If resin is used in any one of the components, the system cannot be used in a high-temperature environment. The recommended operating temperature ranges for each type of linear system are listed in Table 1-23.

Table 1-23 Material Type and Recommended Temperature Range

component material	includes resin	steel	stainless	other
operating temperature range	-20°C ~80°C	-20°C ~110°C	-20°C ~140°C	
slide guide	SEB-A/SEBS-B/GL/SGL/SGW	SER	SEBS-BM/SERS	
ball spline	SSP/SSPF/SSPB		SPLFS	
rotary ball spline	SPR			
slide bush	GM/SM G/KB G/ SW G/SMS G/ KBS G/SWS G	SM/KB/SW	SMS/KBS/SWS	
slide unit	SMA G/AK G/RB/RBW/ TKA/TWA/CE/CD	SMA/AK/SWA	SMSA/AKS/SWSA	
stroke bush		SR/SRB		
slide rotary bush	RK	SRE		
slide way		SV/SVW/RV	SVS/SVWS	
slide table		SVT/SYT	SYTS/SYBS	SVTS**
slide screw		SS		

* If the system is made of stainless steel and has a seal, the temperature should be below 120°C

** Contact NB if system is to be used at temperatures beyond the recommended temperature ranges.

Temperature conversion equation

$$C = \frac{5}{9}(F-32) \quad F = 32 + \frac{9}{5}C$$

Operating Environment:

Dust and particle debris will adversely affect the motion characteristics of a linear system. They can also cause abnormally fast wear. In a normal operating environment, the use of seals may prevent adverse effects to the linear system. However, the linear system should be well protected by using bellows or a protective cover when it is used in an extremely hostile environment. (Figure 1-10)

Figure 1-10 Example of Dust Prevention Devices

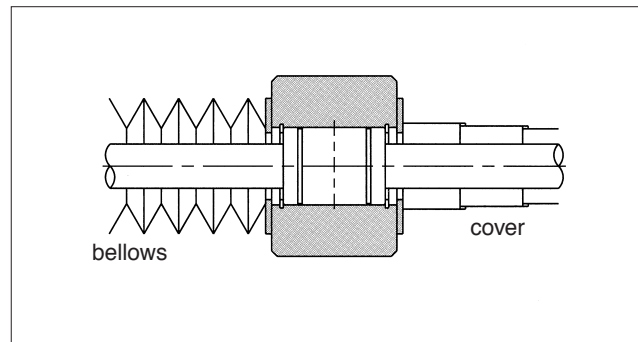



LUBRICATION

The objective of lubrication includes the reduction of friction between the rolling elements and between the rolling elements and the rolling surface, prevention of seizure, reduction of wear, and the prevention of rusting by forming a film over the surfaces. To maximize the performance of a linear system, a lubrication method and a lubricant appropriate for the operating environment should be selected.

Methods of lubrication include oil lubrication and grease lubrication. For oil lubrication, turbine oil conforming to ISO standard VG32-68 is recommended. For grease lubrication, lithium soap based grease No.2 is recommended.

Only rust preventative oil that does not adversely affect the lubricant is applied in a slide bush and some other products. Those products should be lubricated before it is placed into service. Products with raceway grooves, such as slide guides, are delivered pre-lubricated with grease and may be installed and used without further lubrication. Through operation lubricant is dispersed, so it is advisable to re-lubricate periodically depending on application and usage. The recommended lubricant replenishment interval is about 6 months under normal use conditions.

NB provides the following greases. Please use them in accordance with the use conditions of your linear system.

● KGL Grease (Low Dust Generation Grease)

KGL Grease has an excellent property of low dust generation with a lithium-type thickening agent used. It is ideal for use in a clean room.

● KGU Grease (Low Dust Generation Grease)

With urea-type thickening agent used, KGU Grease has features including a superior low dust generation property and the reduced dynamic friction resistance during low-speed operation.

Table 1-24 Main Property

item	grease name	
	KGL Grease	KGU Grease
appearance	light yellowish-white	light brown
base oil	synthetic oil and refined oil mixed	synthetic oil and refined oil mixed
kinematic viscosity of base oil (mm ² /s, 40°C)	32	approx. 85
thickening agent	lithium soap	urea
mixture viscosity	237	246
drop point (°C)	201	250 or higher
copper plate corrosion (100°C, 24hrs)	passed	passed
evaporation	0.8(99° 22h)	0.61(150° 22h)
oil separation (100°C, 24hrs)	0.9	0.1
oxidation stability (99°C, 100hrs)	0.04	0.015
bearing corrosion prevention (52°C, 48hrs)	passed	passed
operating temperature range (°C)	-20~120	-20~150



Figure 1-11 Dust Level Measurement Data

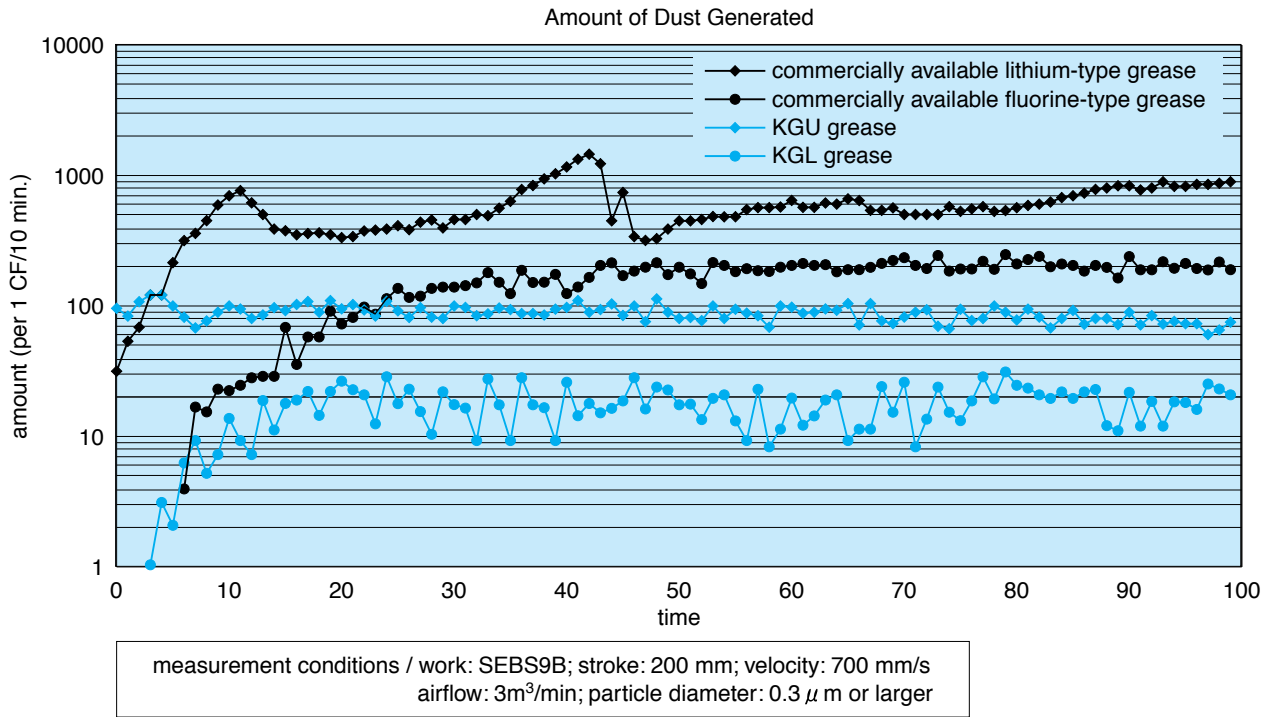
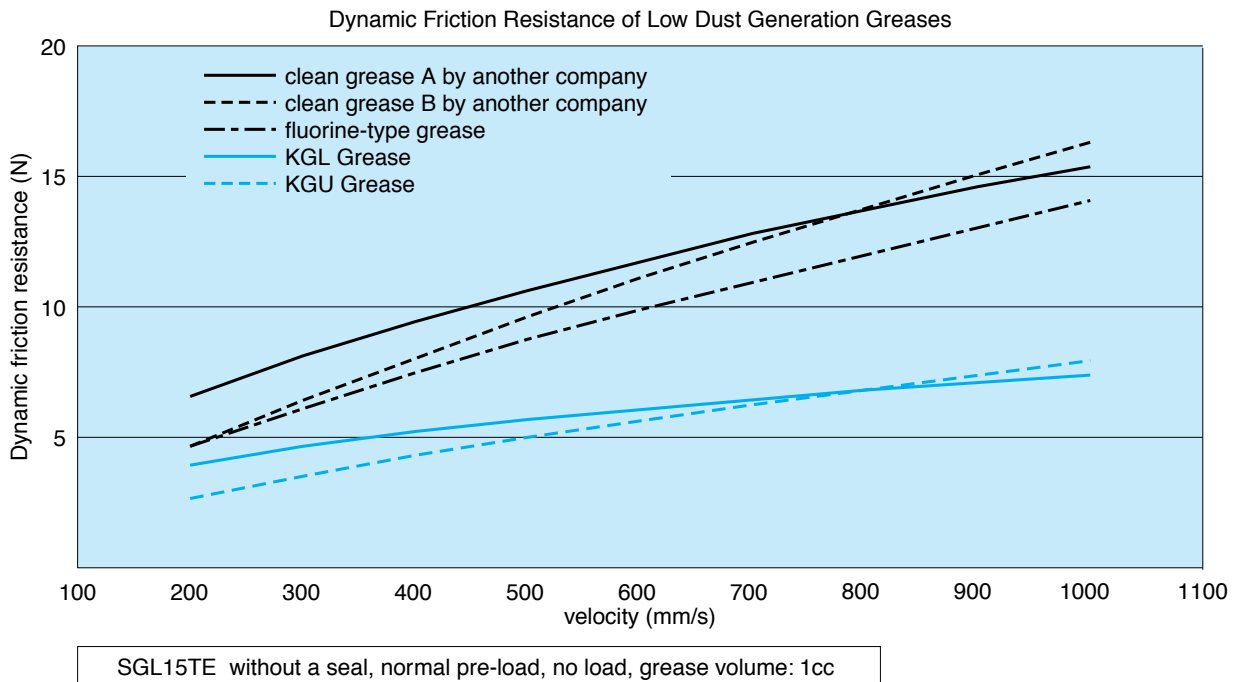

Figure 1-12 Dynamic Friction Resistance Measurement Data





●KGF Grease (Anti-fretting/Anti-corrosion Grease)

With urea-type thickening agent used, KGF Grease is very effective to prevent fretting and corrosion.

Table 1-25 Main Property

item	grease name
	KGF Grease
appearance	brown
base oil	synthetic oil
kinematic viscosity of base oil (mm ² /s, 40°C)	approx. 25
thickening agent	urea
mixture viscosity	292
drop point (°C)	250 or higher
copper plate corrosion (100°C, 24 hrs)	passed
evaporation	0.27(99° 22h)
oil separation (100°C, 24 hrs)	1.1
oxidation stability (99°C, 100 hrs)	0.085
bearing corrosion prevention (52°C, 48 hrs)	passed
rinsing water resistance (38°C, 1 hr)	1.7
operating temperature range (°C)	-20~150

Anti-Fretting/Anti-Corrosion Test Data

Table 1-26 Test Conditions

item	content
tested item	NVT4165
stroke	2 mm
acceleration	2.4G
average acceleration	5.8 m/min
cycle rate	1,450 cpm
grease injection volume	0.5 cc
total travel distance	184 km
total cycle counts	46 million cycles

Figure 1-13 Raceway Condition after Testing

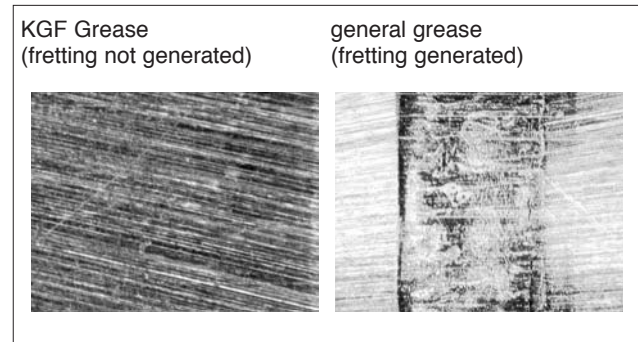

Other Greases

In addition to KGL, KGU, and KGF Greases, NB also provides K Grease, urea-type low dust generation grease.

Table 1-27 Main Property

item	grease name
	K Grease
appearance	yellow white
thickening agent	urea-type
base oil	synthetic oil
viscosity	280(No.2)
operating temperature range (°C)	-30~150



NOTES ON HANDLING AND USE

Follow the instructions below to maintain the accuracy of NB linear system as a precision part and to use it safely.



(1) Notes on Handling

- ① Any shock load caused by rough handling (such as dropping or hitting with hammer) may cause a scar on the raceway which will hinder smooth movement and shorten expected travel life. Also be aware that such impact may damage the resin parts.
- ② Never try to disassemble the product. Doing so may cause an entry of contamination or deterioration of assembly accuracy.
- ③ The blocks or the outer cylinders may move just by tilting the rail or the shaft. Be careful not to let them fall off from the rail or the shaft by mistake.
- ④ The accuracy on the mounting surface and parallelism of the shafts after assembly are important factors for exploiting the performance of the linear system. Exercise adequate care for mounting accuracy.



(2) Notes on Use

- ① Be careful not to let dust or foreign substances enter the linear system during use.
- ② When using the linear system under an environment where dust or coolant may scatter, protect the system with a bellow or a cover.
- ③ When the NB linear system is used in a manner that its rail is fixed to the ceiling and downward load is applied to the block(s) or the outer cylinder(s), if the block or the outer cylinder breaks, it may fall off from the rail and drop to the floor. Provide additional measures for preventing dropping of the block or the outer cylinder, such as a safety catch.



(3) Instructions in considering the "Life Span" of a Linear System

- ① When the load applied to a block or an outer cylinder exceeds 0.5 time of the basic dynamic load rating ($P > 0.5C$), the actual life of the system may become shorter than a calculated life span. Therefore, it is recommended to use the system with 0.5C or lower.
- ② In the repetition of very small strokes, where a rolling element, such as a steel ball or a cylindrical roller, makes only half-turns or smaller, early wear called fretting occurs at the contact points between the rolling element and the raceway. There is no perfect measure for this, but the life of the system can be extended by using anti-fretting grease and moving the blocks or the outer cylinders for the full stroke length once in several thousand times of use.
Anti-fretting grease is available at NB. Please use it before using the linear system with very minute stroke cycles.