



NEW PRODUCT

SLIDE BUSH

Nippon Bearing has expanded the new generation GM Slide Bush series to now include the popular Double-Wide and Flange Types to provide an even wider selection of products.

GM (single type)

GM-W (double-wide type)

GMF-W (round flange double-wide type)

GMK-W (square flange double-wide type)

GMT-W (two side cut double-wide flange type)



Certificate No.958188



PACIFIC INTERNATIONAL BEARING SALES, INC.
800.228.8895 • WWW.PACIFICBEARINGSALES.COM



NIPPON BEARING CO., LTD.

New Lineup of NB GM Slide Bush

NIIPON Bearing's new generation of lightweight, low noise GM Slide Bush series has been expanded to now include the Double-Wide and Flange types with the benefits and features described below.

STRENGTH and STABILITY:	Double-Wide Type	GM-W
EASY INSTALLATION:	Round Flange Double-Wide Type	GMF-W
	Square Flange Double-Wide Type	GMK-W
	Two Side Cut Double-Wide Flange Type	GMT-W

Each of these new products are available in standardized sizes for shaft diameters ranging from 6mm through 30mm.

NB's GM Slide Bush series features an outer cylinder "load section" made of hardened steel and a "ball return section" made of resin. The two sections are formed together as one unit resulting in an overall weight reduction of 30~50% when compared to our traditional SM Slide Bush, while maintaining equivalent accuracies and capacities. The Double-wide/Flange Double-wide products have been added to meet the needs of wide variety of application requirements. This new generation Slide Bush will respond to the demands of "low-cost" as well as broaden the application scope of Slide Bush.

STRUCTURE AND FEATURES

NB's GM Slide Bush consists of an outer cylinder casing, steel balls, and ball retainer. The outer cylinder casing is steel combined with resin and is formed by precision grinding processes.

Lightweight

The GM Slide Bush makes efficient use of resin components making it possible to achieve an overall weight reduction of 30~50% when compared with the SM Slide Bush.

Compact Size

The GM-W Slide Bush is shorter in overall length when compared with the SM-W Slide Bush, while maintaining equivalent rated loads. This allows for full use of installation space and stroke.

Low Noise Design

The ball return section is configured completely in resin material, which provides for low noise operation.

Smooth Movement, High Acceleration/Deceleration Support

The GM Slide Bush provides smooth movement under high acceleration/deceleration motion through the accurately lined-up circulation of the balls, a lightweight structure.

Product Configurations

The GM Slide Bush series is now available in three main types: Single, Double-Wide, and Double-Wide with flange. Each type is available for shaft diameters ranging from 6mm through 30mm. The Double-Wide Flange type may be provided with either Round, Square, or Two Side Cut flanges.

Seal

An optional integral resin seal is also available.

Figure 1: Structure of GM/GM-W slide bush

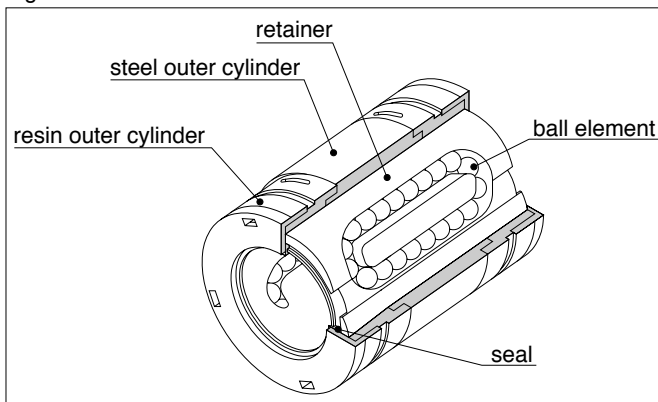
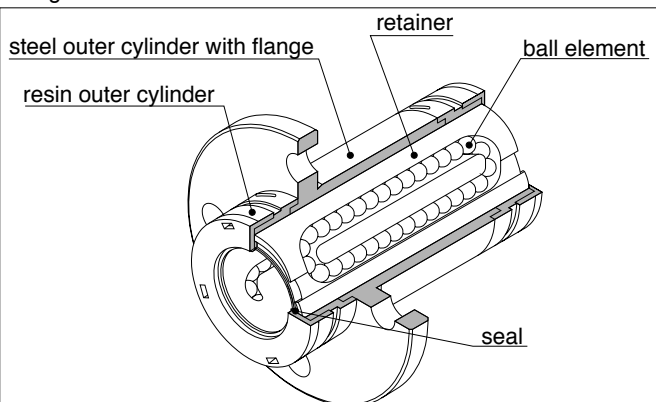

Figure 2: Structure of GMF-W slide bush





SPECIFICATIONS

Allowable Load

NB's GM Slide Bush is classified into either a Single or Double-Wide type in terms of the outer cylinder length. Table 1 below lists comparative allowable loads. A Double-Wide Slide Bush is recommended if the Slide Bush is expected to withstand moment loads.

Table 1: Comparison of allowable loads

series	basic dynamic load rating	basic static load rating	allowable static moment
GM single type	1	1	1
GM double-wide type	1.6	2	Approx. 4
*SM double-wide type	1.6	2	Approx. 6
* Triple-wide type	1.6	2	Approx. 21

Note: Single type is assigned a load of 1 for comparison purposes only.
* SM-series reference values

INSTALLATION

Table 2: Recommended Fit for Single and Double-Wide Types

series	accuracy grade	shaft		housing
		clearance fit	transition fit	clearance fit
GM	High	g6	h6	H7
GM-W	High	g6	—	H7

Table 3: Recommended Fit for Double-Wide Type with Flange Type

series	accuracy grade	shaft
		clearance fit
GMF-W	High	g6
GMK-W	High	g6
GMT-W	High	g6

A flange type Slide Bush is most commonly inserted into a hole with a dimension larger than its outer cylinder. An H7 bore tolerance is recommended for applications that require the steel outer cylinder to be used as the pilot. Additionally, the GM type flange installation should be performed as illustrated in Figure 3. The resin outer cylinder portion must not be used as a pilot.

Installation Notes

When inserting the GM Slide Bush into a housing, apply an even force to the end of the outer cylinder using a jig such as shown in Figure 4. Handle carefully as a precision component; do not subject to strong shocks by dropping or hammering on the resin outer cylinder.

When using two or more shafts, it is very important to maintain the parallelism between shafts, as this will greatly affect the smoothness of movement and component life. Adjust the parallelism as needed to achieve smooth movement during the operation of a GM Slide Bush.

Figure 3: Recommended Flange Installation

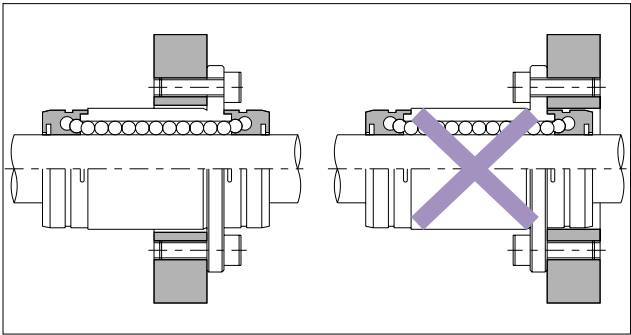
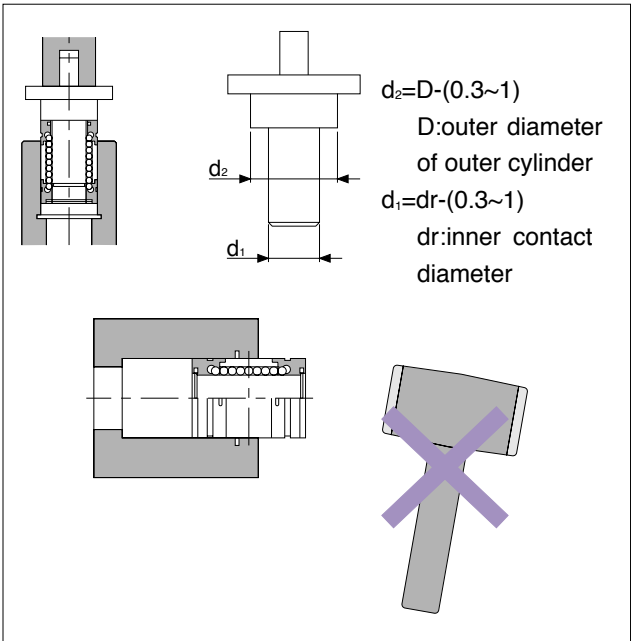

Figure 4: Recommended Installation method





GM TYPE

— Single-Type —

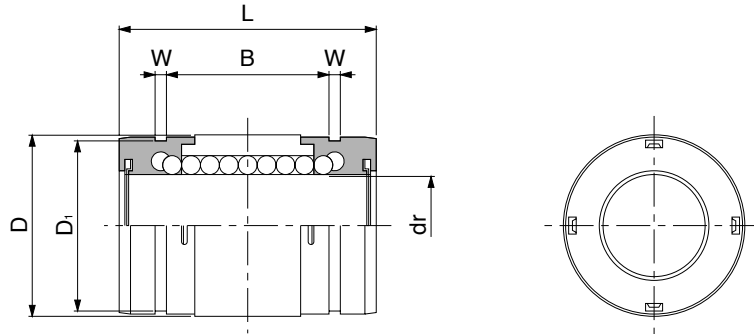
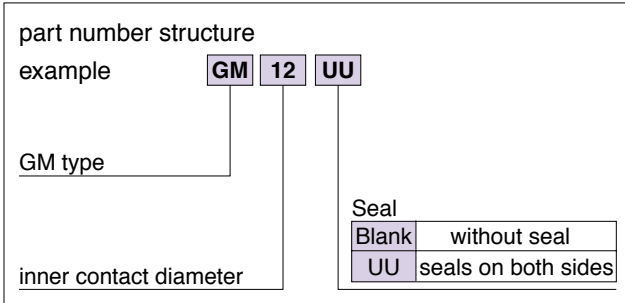

part number	number of ball circuits	major dimensions								basic load rating		mass g
		dr		D		L	B	W	D ₁	dynamic C N	static C ₀ N	
		mm	tolerance μm	mm	tolerance μm							
GM 6	4	6		12	0	19	11.3	1.1	11.5	206	265	5
GM 8	4	8		15	-11	24	15.3	1.1	14.3	274	392	10
GM 10	4	10	0	19		29	19.4	1.3	18	372	549	18
GM 12	4	12	-9	21	0	30	20.4	1.3	20	510	784	23
GM 13	4	13		23	-13	32	20.4	1.3	22	510	784	27
GM 16	4	16		28		37	23.3	1.6	27	774	1,180	45
GM 20	6	20	0	32	0	42	27.3	1.6	30.5	882	1,370	70
GM 25	6	25		40		59	37.3	1.85	38	980	1,570	150
GM 30	6	30	-10	45	-16	64	40.8	1.85	43	1,570	2,740	180

GM-AJ type of slide bush (adjustable clearance type) is also manufactured. Please contact NB for details.

1N ≒ 0.102kgf



GM-W TYPE

— Double-Wide-Type —

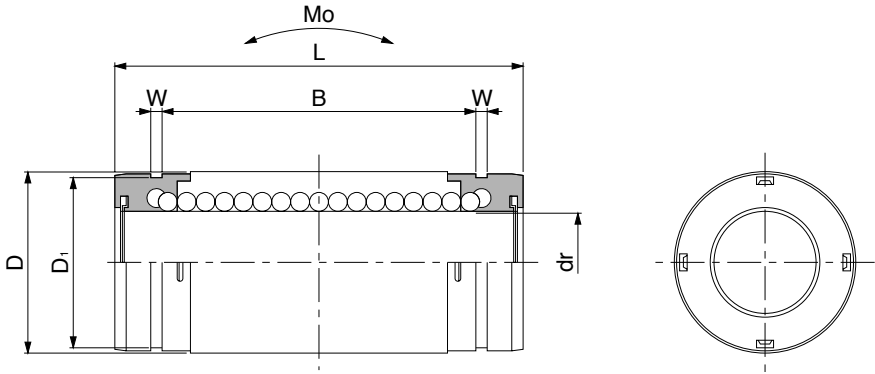
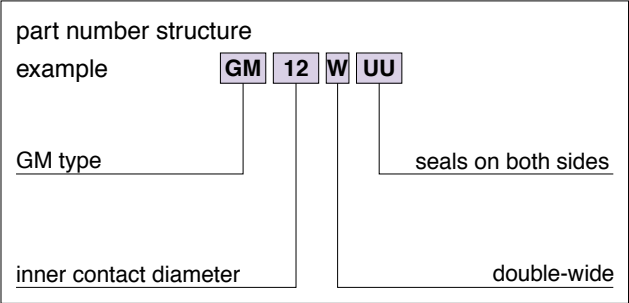
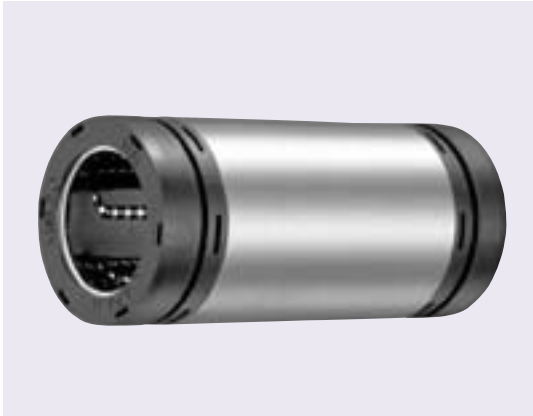

part number	number of ball circuits	major dimensions								basic load rating		allowable static moment Mo N · m	mass g
		dr		D		L	B	W	D ₁	dynamic C N	static Co N		
		mm	tolerance μm	mm	tolerance μm								
GM 6W UU	4	6	0	12	0	28	20.3	1.1	11.5	323	530	1.5	9
GM 8W UU	4	8		15	-13	36	27.3	1.1	14.3	431	784	3.3	18
GM 10W UU	4	10		19	0	41	31.4	1.3	18	588	1,100	5.0	31
GM 12W UU	4	12		21	0	46	36.4	1.3	20	813	1,570	7.6	42
GM 13W UU	4	13		23	-16	48	36.4	1.3	22	813	1,570	8.1	50
GM 16W UU	4	16		28	-16	53	39.3	1.6	27	1,230	2,350	13.8	76
GM 20W UU	6	20	0	32	0	65	50.3	1.6	30.5	1,400	2,740	20.0	130
GM 25W UU	6	25		40	0	91	69.3	1.85	38	1,560	3,140	34.8	280
GM 30W UU	6	30		45	-19	99	75.8	1.85	43	2,490	5,490	57.5	334

1N ≙ 0.102kgf 1N · m ≙ 0.102kgf · m

GMF-W TYPE

— Round Flange Double-Wide Type —

GMK-W TYPE

— Square Flange Double-Wide Type —

GMT-W TYPE

— Two Side Cut Double-Wide Flange Type —

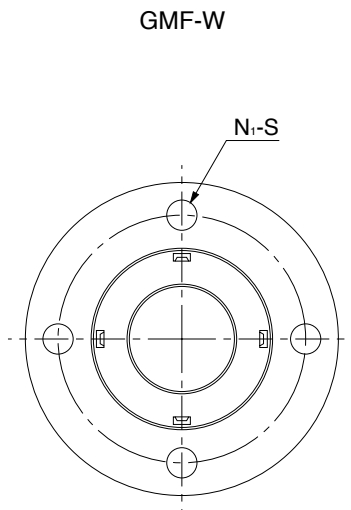
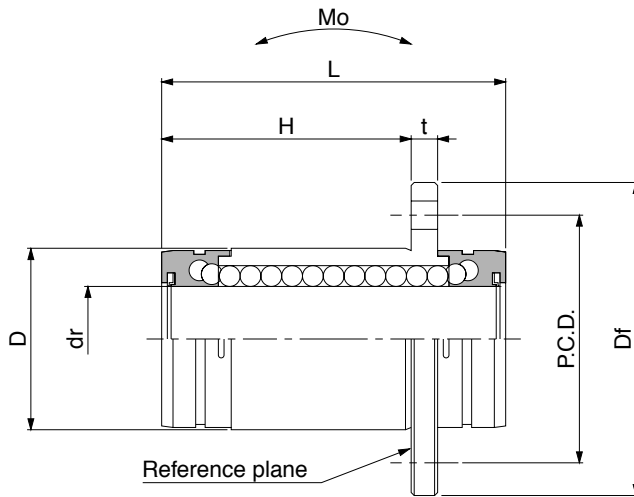
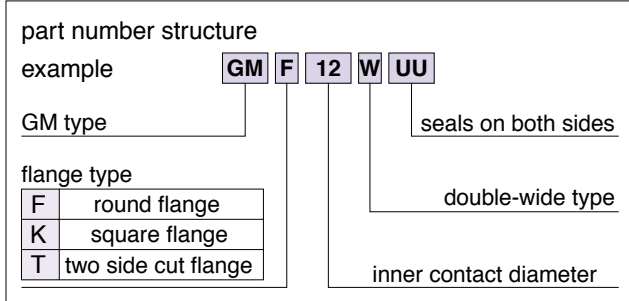
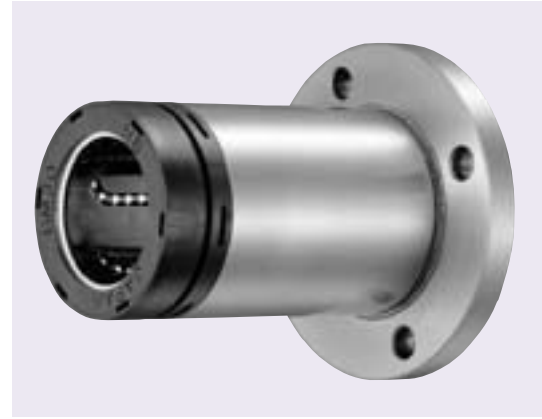

part number			number of ball circuits	major dimensions							
round flange double wide type	square flange double wide type	two side cut double wide flange type		dr tolerance	D tolerance	L	H	Df	t		
			mm	μm	mm	μm	mm	mm	mm	mm	
GMF 6W UU	GMK 6W UU	GMT 6W UU	4	6	12	0	28	17.8	28	4	
GMF 8W UU	GMK 8W UU	GMT 8W UU	4	8	15	-13	36	25.1	32	4	
GMF 10W UU	GMK 10W UU	GMT 10W UU	4	10	19	0	41	28.2	40	4	
GMF 12W UU	GMK 12W UU	GMT 12W UU	4	12	21	-10	46	34.2	42	4	
GMF 13W UU	GMK 13W UU	GMT 13W UU	4	13	23	-16	48	34.7	43	4	
GMF 16W UU	GMK 16W UU	GMT 16W UU	4	16	28	0	53	38.3	48	4	
GMF 20W UU	GMK 20W UU	GMT 20W UU	6	20	32	0	65	49.2	54	5	
GMF 25W UU	GMK 25W UU	GMT 25W UU	6	25	40	-12	91	70.5	62	5	
GMF 30W UU	GMK 30W UU	GMT 30W UU	6	30	45	-19	99	74.3	74	8	



SLIDE BUSH

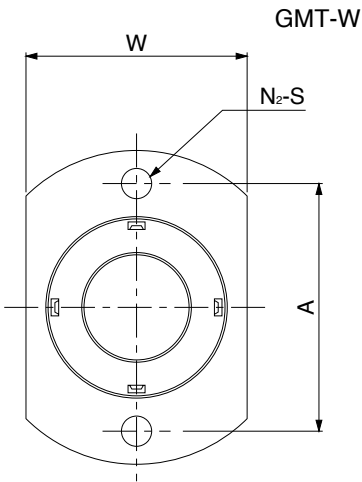
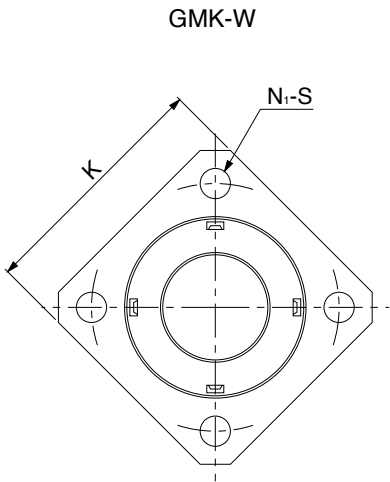
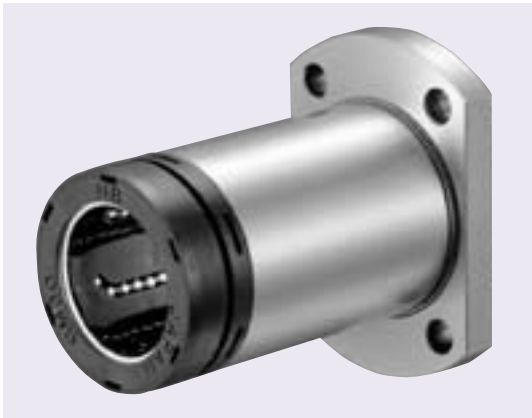
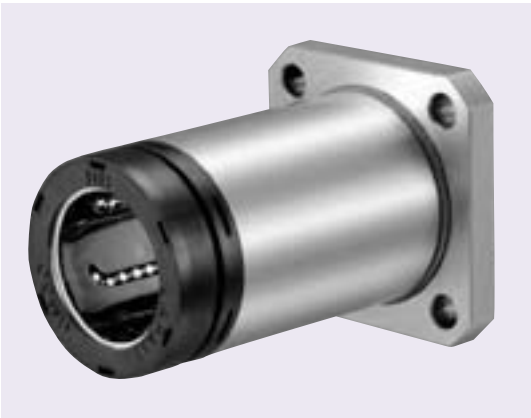

GMT13W or smaller

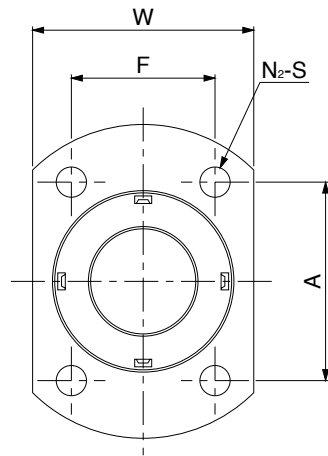

GMT16W or larger

flange							perpen- dicularity μm	basic load rating		allowable static moment $\text{N} \cdot \text{m}$	mass		
GMF-W/GMK-W			GMT-W					Dynamic C N	Static Co N		g		
P.C.D. mm	K mm	$\text{N}_1\text{-S}$ mm	W mm	A mm	F mm	$\text{N}_2\text{-S}$ mm				GMF-W	GMK-W	GMT-W	
20	22	4-3.5	18	20	—	2-3.5	15	323	530	1.5	25	20	21
24	25	4-3.5	21	24	—	2-3.5		431	784	3.3	38	32	33
29	30	4-4.5	25	29	—	2-4.5		588	1,100	5.0	62	50	52
32	32	4-4.5	27	32	—	2-4.5		813	1,570	7.6	75	63	65
33	34	4-4.5	29	33	—	2-4.5		813	1,570	8.1	83	72	74
38	37	4-4.5	34	31	22	4-4.5		1,230	2,350	13.8	115	99	104
43	42	4-5.5	38	36	24	4-5.5	20	1,400	2,740	20.0	188	165	171
51	50	4-5.5	46	40	32	4-5.5		1,560	3,140	34.8	350	325	331
60	58	4-6.6	51	49	35	4-6.6		2,490	5,490	57.5	502	437	447

1N \approx 0.102kgf 1N \cdot m \approx 0.102kgf \cdot m



NIPPON BEARING CO., LTD.

Local Sales Representative:



PACIFIC INTERNATIONAL BEARING SALES, INC.
800.228.8895 • WWW.PACIFICBEARINGSALES.COM

No. 2530

First Edition: May 31, 2002