

CE TYPE

– Non-Clearance Adjustable Type –

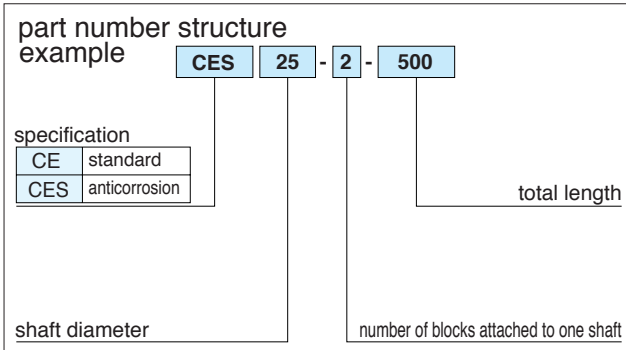
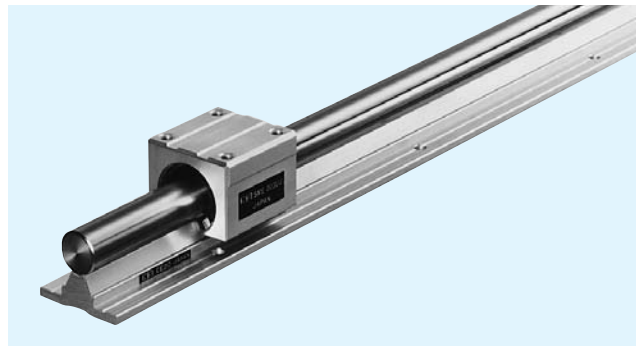

part number		shaft diameter mm	assembly dimension											major dimensions					
standard	anticorrosion		H	h	W ₁	W ₂	L ₁	B ₁	C	T ₁	ℓ	S ₁	F	W ₃	B ₂	T ₂	P	S ₂	
CE16	CES16	16	45	25	2.5	45	45	32	30	9	12	M5	33	40	30	5	150	5.5	
CE20	CES20	20	50	27	1.5	48	50	35	35	11	12	M6	39	45	30	5	150	5.5	
CE25	CES25	25	60	33	2.5	60	65	40	40	14	12	M6	47	55	35	6	200	6.5	
CE30	CES30	30	70	37	5	70	70	50	50	15	18	M8	56	60	40	7	200	6.5	

* Longer length are available. Please contact NB in case of the length exceeds 2,000mm.



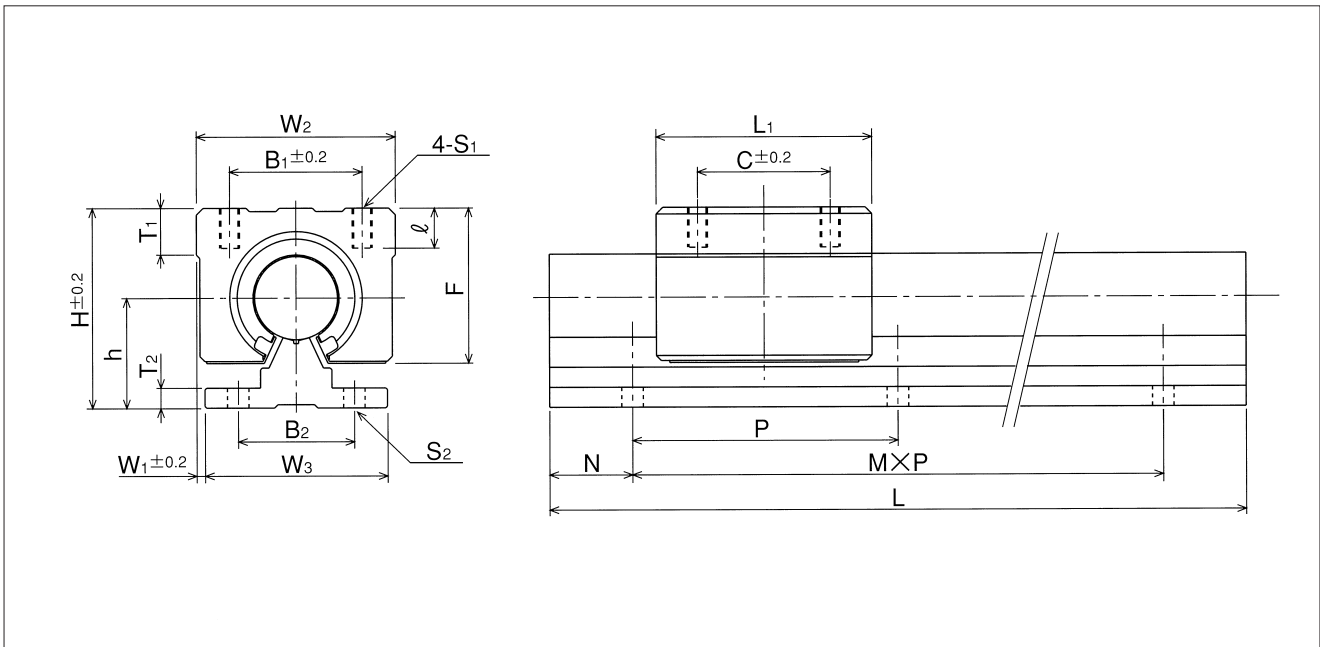

rail dimensions				basic load rating		mass		size
				dynamic C N	static Co N	block g	rail kg/m	
*L(M,N) mm								
300(1,75)	500(3,25)	800(5,25)	1,000(6,50)	774	1,180	150	2.58	16
1,500(9,75)	1,800(11,75)	2,000(13,25)						
300(1,75)	500(3,25)	800(5,25)	1,000(6,50)	882	1,370	200	3.49	20
1,500(9,75)	1,800(11,75)	2,000(13,25)						
300(1,50)	500(2,50)	800(3,100)	1,000(4,100)	980	1,570	450	5.31	25
1,500(7,50)	1,800(8,100)	2,000(9,100)						
300(1,50)	500(2,50)	800(3,100)	1,000(4,100)	1,570	2,740	630	7.39	30
1,500(7,50)	1,800(8,100)	2,000(9,100)						

1N \approx 0.102kgf



PACIFIC INTERNATIONAL BEARING SALES, INC.
800.228.8895 • WWW.PACIFICBEARINGSALES.COM

CD TYPE

– Clearance Adjustable Type –

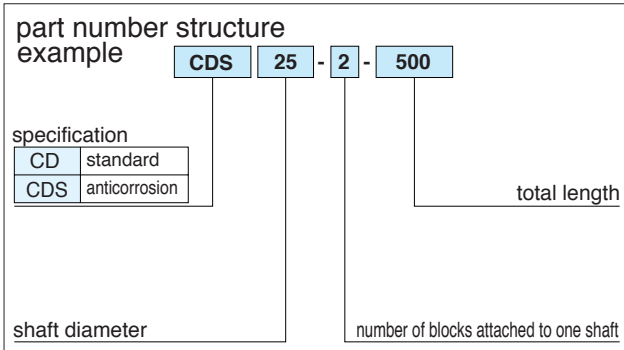
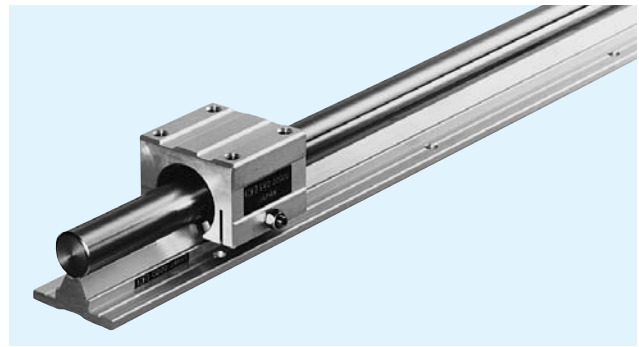

part number		shaft diameter mm	assembly dimensions											major dimensions					
standard	anticorrosion		H	h	W ₁	W ₂	L ₁	B ₁	C	T ₁	ℓ	S ₁	G	F	W ₃	B ₂	T ₂	P	S ₂
CD16	CDS16	16	45	25	5	50	45	36	30	9	12	M5	6	33	40	30	5	150	5.5
CD20	CDS20	20	50	27	4.5	54	50	40	35	11	12	M6	7	39	45	30	5	150	5.5
CD25	CDS25	25	60	33	10.5	76	65	54	40	14	12	M6	7	47	55	35	6	200	6.5
CD30	CDS30	30	70	37	9	78	70	58	50	15	18	M8	7	56	60	40	7	200	6.5

* Longer length are available. Please contact NB in case of the length exceeds 2,000mm.



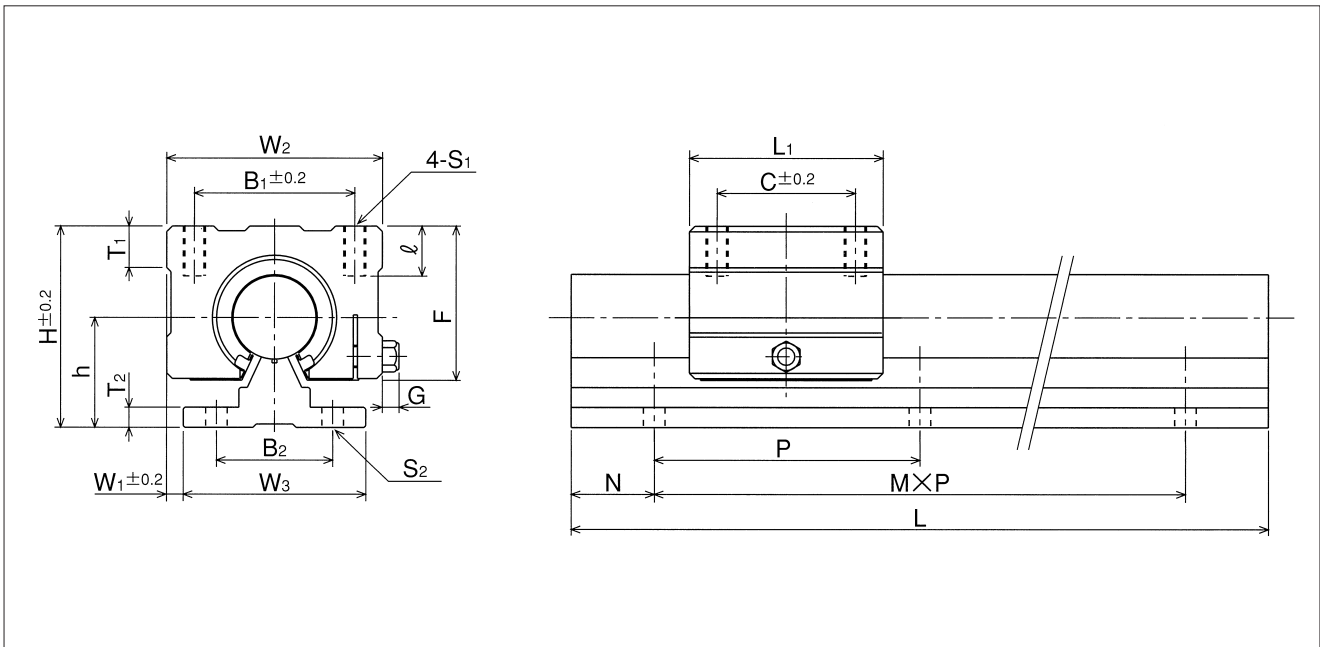

rail dimensions				basic load rating		mass		size
				dynamic C N	static C ₀ N	block g	rail kg/m	
*L(M,N) mm								
300(1,75)	500(3,25)	800(5,25)	1,000(6,50)	774	1,180	170	2.58	16
1,500(9,75)	1,800(11,75)	2,000(13,25)						
300(1,75)	500(3,25)	800(5,25)	1,000(6,50)	882	1,370	240	3.49	20
1,500(9,75)	1,800(11,75)	2,000(13,25)						
300(1,50)	500(2,50)	800(3,100)	1,000(4,100)	980	1,570	580	5.31	25
1,500(7,50)	1,800(8,100)	2,000(9,100)						
300(1,50)	500(2,50)	800(3,100)	1,000(4,100)	1,570	2,740	720	7.39	30
1,500(7,50)	1,800(8,100)	2,000(9,100)						

1N≐0.102kgf



PACIFIC INTERNATIONAL BEARING SALES, INC.
800.228.8895 • WWW.PACIFICBEARINGSALES.COM