

# ACTUATOR



PACIFIC INTERNATIONAL BEARING SALES, INC.  
800.228.8895 • [WWW.PACIFICBEARINGSALES.COM](http://WWW.PACIFICBEARINGSALES.COM)

SLIDE GUIDE

BALL SPLINE  
ROTARY BALL SPLINE  
STROKE BALL SPLINE

TOPBALL® PRODUCTS

SLIDE BUSH

SLIDE UNIT

STROKE BUSH  
SLIDE ROTARY BUSH

SLIDE SHAFT

SLIDE WAY/GONIO WAY  
SLIDE TABLE  
MINIATURE SLIDE

ACTUATOR

SLIDE SCREW

# ACTUATOR

NB's BG type is a compact single axis actuator which integrates a slide guide and precision ball screw.

BG type offers compact dimensions and outperforms conventional positioning tables. This is made possible by a unique "U" shaped guide rail and slide block which provides multiple functions of a guide block and a ball screw nut combined into a single unit. The "U" shaped guide rail design offers a high rigid structure resistant to bending. This structural feature allows for integrated framework of machinery or equipment and may be one-end supported. Additionally, the slide block contains 4 ball circuits which delivers high load capacity, high accuracy and high rigidity.

Figure I-1 Structure of BG type

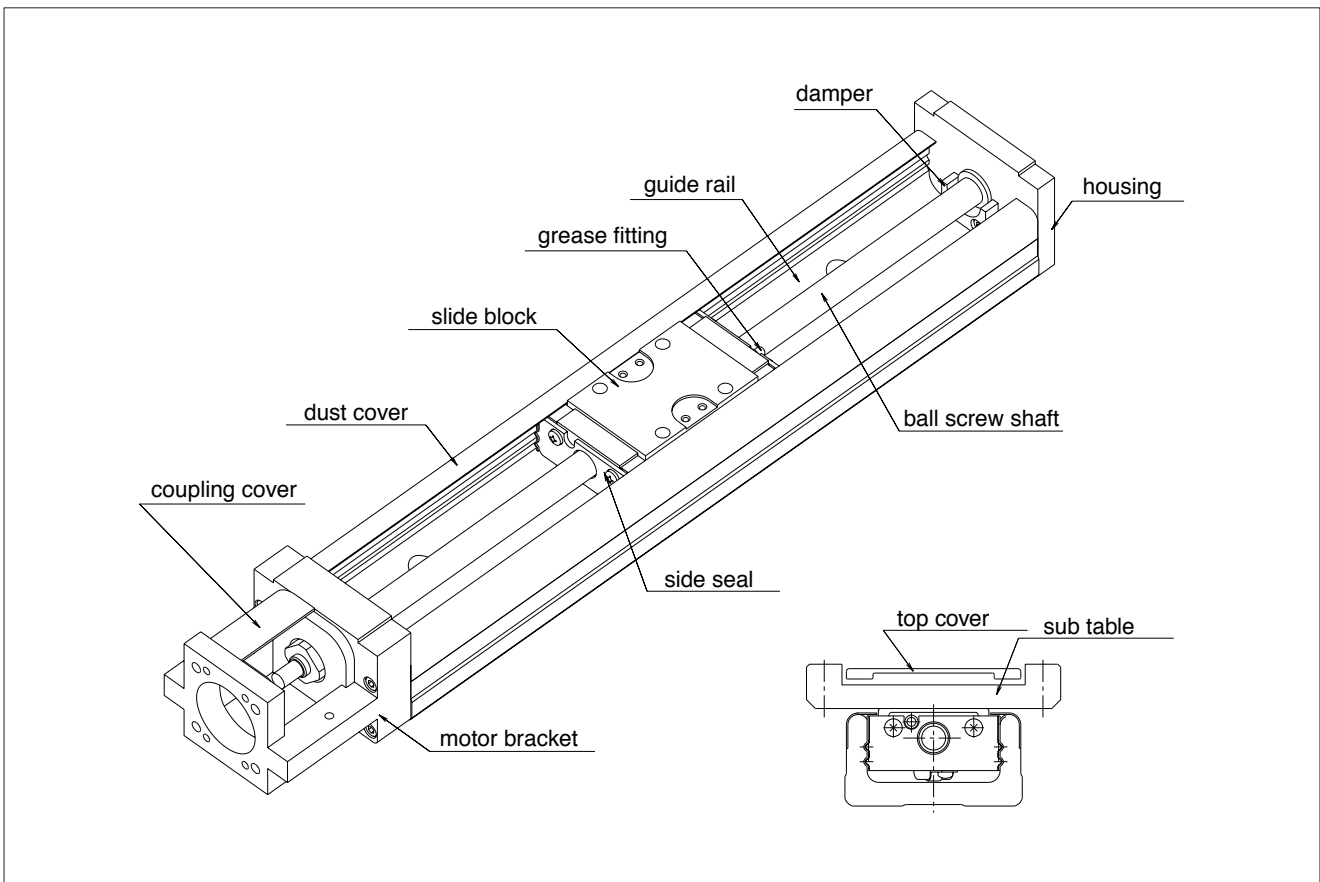



## ADVANTAGES

### Adjustment Free:

The integration of the slide guide and precision ball screw eliminates complex precision adjustment and reduces installation time dramatically.

### High Rigidity:

"U" shaped guide rail provides very high rigidity despite its compact configuration and can be used for one-end supported application. (Reference Page I-9)

### High Accuracy:

BG type contains four ball circuits and four-point contact ball grooves which contributes to its high rigidity. The combination of precision ground guide rail, slide block and precision ball screw provides high positioning accuracy.

### Space Saving:

In comparison to conventional positioning tables, the BG type allows for compact designs and dramatic space saving. The "U" shaped guide rail and integrated slide block / precision ball screw nut make this possible.

Figure I-2 Ball Contact View

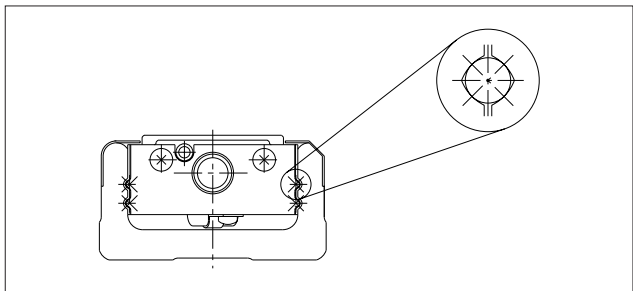
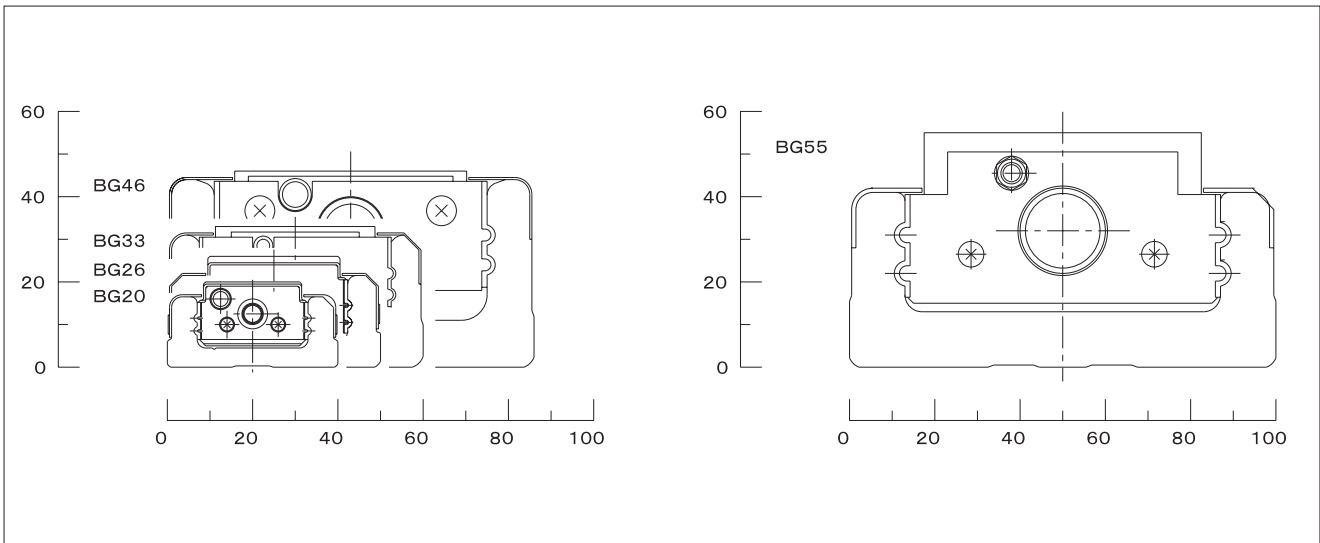

Figure I-3 Cross Sectional View





## PART NUMBER SYSTEM

Part number for BG type is described as follows.

①	②	③	④	⑤	⑥	⑦	⑧	⑨	⑩
BG	20	01	A	100	H	A0			P△
		05	B	150	P	A1	C	S	G▲
				200		A3		K	RD
						A4			PNP
						A5			
						A6			
						A7			
						A8			
						A9			
						R0			

- ① BG type
- ② size
- ③ ball screw lead
- ④ type of block

A	with 1 long block
B	with 2 long blocks ※
C	with 1 short block
D	with 2 short blocks ※

※ Driver block is located closest to motor mount bracket side.

①	②	③	④	⑤	⑥	⑦	⑧	⑨	⑩
BG	26	02	A	150	H	A0			P△
		05	B	200	P	A1	C	S	G▲
				250		A3		K	RD
				300		A5			PNP
						A6			
						A7			
						A8			
						A9			
						R0			

- ⑤ guide rail length
- ⑥ precision grade

H	high grade
P	precision grade

①	②	③	④	⑤	⑥	⑦	⑧	⑨	⑩
BG	33	05	A	150	H	A0			P△
		10	B	200	P	A1	C	S	G▲
			C	300		A2		H	RD
			D	400		A3		K	PNP
				500		A4			
				600		A5			
						B1			
						R0			
						RA□			
						RB□			

- ⑦ motor bracket (refer to page I-8)  
The number in the square, □, after suffix RA, RB or RC indicates the mounting direction.
- ⑧ cover

none	without top-cover
C	with top-cover ※

※ top-cover and auxiliary table.

①	②	③	④	⑤	⑥	⑦	⑧	⑨	⑩
BG	46	10	A	340	H	A0			P△
		20	B	440	P	A1	C	S	G▲
			C	540		A2		H	RD
			D	640		A3		K	PNP
				740		A4			
				840		B0			
				940		C0			
				1040		D0			
				1140		R0			
				1204		RA□			
						RB□			
						RC□			

- ⑨ Sensor

none	without sensor
S	with slim type photo sensor
H	with close contact type photo sensor
K	with proximity sensor

①	②	③	④	⑤	⑥	⑦	⑧	⑨	⑩
BG	55	20	A	980	H	A0			P△
			B	1080	P	A1	C	S	G▲
				1180		A2		H	RD
				1280		A3		K	PNP
				1380		A4			
						R0			

- ⑩ Option

none	without option
P△	with positioning pin hole (※1)
G▲	with grease option (※2)
RD	with raydent treatment (※3)
PNP	with PNP sensor (※4)

Case of multiple option, add + between each option  
Example:(PS+RD+PNP)

※1, portion △ is S or W (see page I-38)

※2, portion ▲ is K, U, L or F (see page I-16)

Grease put in Guide, Ball screw, and Angular Bearing portion

※3, Apply it except aluminum parts and radial bearing

※4, Apply it except BG 20 and 26



## SPECIFICATION

BG Type is categorized as either high grade or precision grade (P).

Table I-1 Specification

part number			BG2001		BG2005		BG2602		BG2605		BG3305		BG3310		BG4610		BG4620		BG5520												
precision grade			high	precision	high	precision	high	precision	high	precision	high	precision	high	precision	high	precision	high	precision	high	precision											
radial clearance			$\mu\text{m}$		-3~0	-6~3	-3~0	-6~3	-4~0	-8~4	-4~0	-8~4	-3~0	-7~3	-3~0	-7~3	-5~0	-11~5	-5~0	-11~5	-6~0	-18~6									
guide	long block	basic dynamic load	C	kN	4.27				7.87				12.6				29.8				43.2										
		basic static load	CO	kN	7.89				14.98				22.7				51.2				74.0										
		allowable static moment	MP	N·m	35				99				181				610				1,088										
			M2P	N·m	199				550				1,035				3,285				5,465										
			MY	N·m	42				118				215				727				1,297										
			M2Y	N·m	237				656				1,233				3,914				6,513										
			MR	N·m	101				255				500				1,612				2,701										
	M2R	N·m	201				509				1,000				3,224				5,402												
	short block	basic dynamic load	C	kN	-				-				7.8				19.9				-										
		basic static load	CO	kN	-				-				11.4				28.8				-										
		allowable static moment	MP	N·m	-				-				49				207				-										
			M2P	N·m	-				-				368				1,336				-										
			MY	N·m	-				-				59				246				-										
			M2Y	N·m	-				-				439				1,593				-										
MR			N·m	-				-				250				907				-											
M2R	N·m	-				-				500				1,814				-													
ball screw	shaft diameter	mm		6				8				10				15				20											
	lead	mm		1		5		2		5		5		10		10		20		20											
	spacer-ball ratio	-		-				-				-		1 : 1		-		1 : 1		-		2 : 1		-		2 : 1					
	basic dynamic load	Ca	kN	0.63		0.65		2.60		2.35		3.35		2.11		2.20		1.39		4.40		2.77		4.40		3.36		5.40		4.12	
	basic static load	Coa	kN	1.34		0.92		3.64		3.30		5.90		2.95		3.50		1.75		7.90		3.95		7.90		5.27		10.50		7.00	
bearing support	part Number	-		AC5-14DF				AC6-16DF				70M8DF/GMP5				7001T2DF/GMP5				7002T2DF/GMP5											
	basic dynamic load	Cb	kN	1.31				1.79				4.40				6.77				7.74											
	basic static load	Cob	kN	1.25				1.76				4.36				7.45				9.50											

\*Please contact NB for details when using BG20-P & BG26-P grade series with short and frequent stroke. (Stroke distance : BG2001 = 7 mm or less, BG2005 = 25 mm or less, BG2602 = 14 mm or less and BG2605 = 25 mm or less)

Figure I-4 Direction of Moment

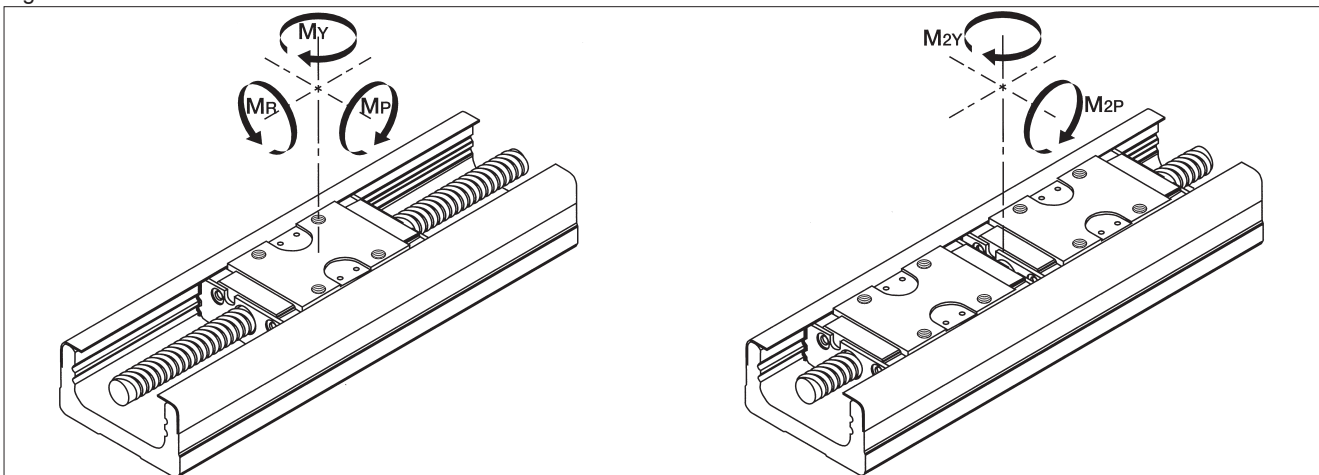

M<sub>2P</sub> and M<sub>2Y</sub> account for the allowable static moment when 2 blocks are used together. (As shown in Figure I-4)



## ALLOWABLE SPEED

Allowable speed of BG type is subject to the type of motor and operating conditions. The speed may also be limited by the critical speed of the ball screw. Use caution when operating at high speeds or using long rails.

Table I-2 Allowable Speed

part number	rail length mm	speed mm/sec
<b>BG2001</b>	100	187
	150	
	200	
<b>BG2005</b>	100	925
	150	
	200	
<b>BG2602</b>	150	281
	200	
	250	
	300	
<b>BG2605</b>	150	694
	200	
	250	
	300	
<b>BG3305</b>	150	550
	200	
	300	
	400	460
	500	
	600	

part number	rail length mm	speed mm/sec
<b>BG3310</b>	150	1,100
	200	
	300	
	400	
	500	930
	600	620
<b>BG4610</b>	340	740
	440	
	540	
	640	
	740	650
	840	500
	940	390
	1040	315
	1140	260
	1240	220

part number	rail length mm	speed mm/sec
<b>BG4620</b>	340	1,480
	440	
	540	
	640	
	740	1,300
	840	1,000
	940	780
	1040	630
<b>BG5520</b>	1140	520
	1240	440
	980	1,120
	1,080	910
	1,180	750
	1,280	630
	1,380	530

Figure I-5 Guide Rail Length and Allowable Speed

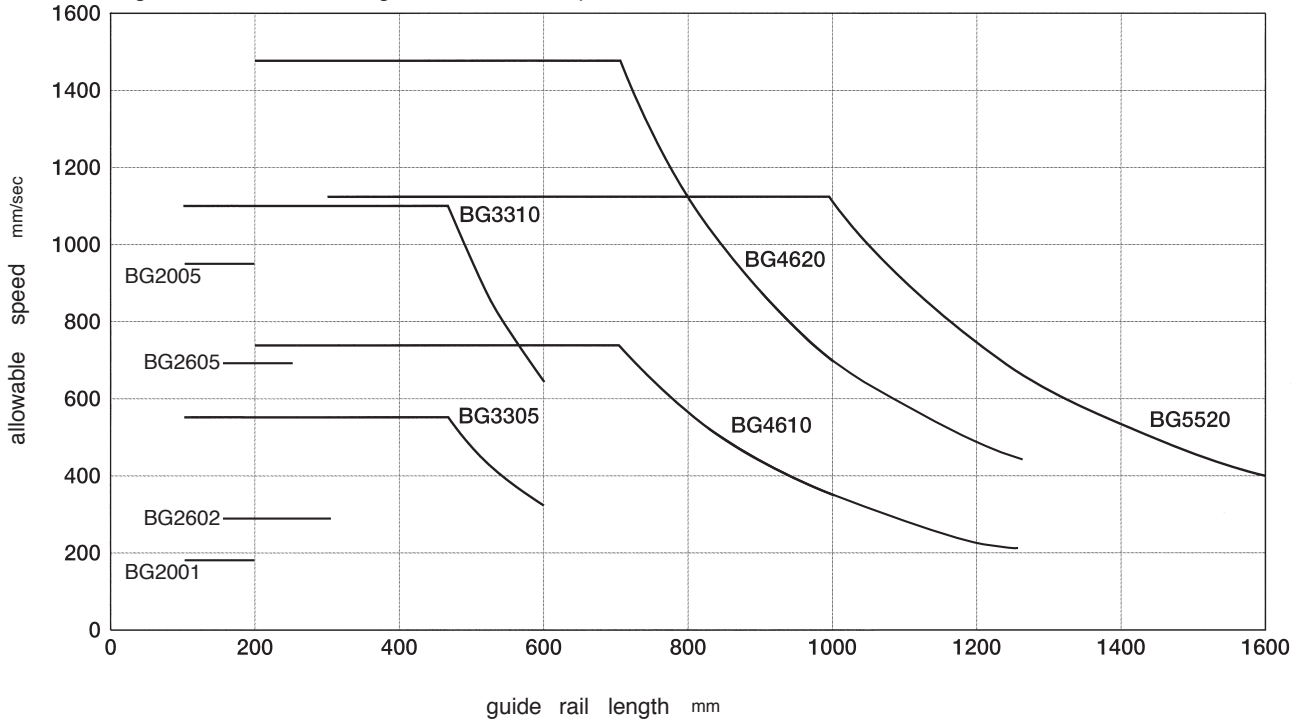



## MASS

The mass of the BG type is listed in Table I-3 and slide block mass is listed in Table I-4.

Table I-3 Mass of BG type Actuator

unit / kg

part number	rail length mm	without top-cover				with top-cover				rail length mm
		long block		short block		long block		short block		
		1block A	2block B	1block C	2block D	1block A	2block B	1block C	2block D	
BG20	100	0.45	0.52	—	—	0.50	0.61	—	—	100
	150	0.58	0.65	—	—	0.63	0.74	—	—	150
	200	0.71	0.78	—	—	0.77	0.88	—	—	200
BG26	150	0.93	1.10	—	—	1.07	1.31	—	—	150
	200	1.14	1.31	—	—	1.30	1.54	—	—	200
	250	1.36	1.53	—	—	1.53	1.78	—	—	250
BG33	300	1.57	1.74	—	—	1.76	2.01	—	—	300
	150	1.6	—	1.5	1.7	1.8	—	1.6	1.9	150
	200	2.0	—	1.8	2.0	2.1	—	2.0	2.2	200
BG33	300	2.6	2.9	2.5	2.7	2.8	3.2	2.6	2.9	300
	400	3.2	3.6	3.1	3.3	3.5	3.9	3.3	3.5	400
	500	3.9	4.2	3.8	3.9	4.2	4.6	4.0	4.2	500
	600	4.6	4.9	4.4	4.6	4.9	5.3	4.7	4.9	600
	340	6.5	7.5	6.0	6.5	7.0	8.0	6.5	7.0	340
BG46	440	8.0	8.5	7.5	8.0	8.5	9.5	8.0	8.5	440
	540	9.0	10.0	8.5	9.5	10.0	11.0	9.5	10.0	540
	640	10.5	11.5	10.0	10.5	11.0	12.5	10.5	11.5	640
	740	12.0	13.0	11.5	12.0	12.5	14.0	12.0	13.0	740
	840	13.0	14.0	13.0	13.5	14.0	15.5	13.5	14.0	840
	940	14.5	15.5	14.0	14.5	15.5	16.5	15.0	15.5	940
	1,040	16.0	17.0	15.5	16.0	17.0	18.0	16.5	17.0	1,040
	1,140	17.5	18.0	17.0	17.5	18.5	19.5	18.0	18.5	1,140
1,240	18.5	19.5	18.5	19.0	19.5	21.0	19.0	20.0	1,240	
BG55	980	20	22	—	—	21	24	—	—	980
	1,080	22	24	—	—	23	26	—	—	1,080
	1,180	23	25	—	—	25	27	—	—	1,180
	1,280	25	27	—	—	27	29	—	—	1,280
	1,380	27	29	—	—	29	31	—	—	1,380

Table I-4 Mass of Blocks

unit / kg

part number	without top-cover		with top-cover	
	long block	short block	long block	short block
BG20	0.07	—	0.11	—
BG26	0.17	—	0.24	—
BG33	0.3	0.15	0.4	0.2
BG46	0.9	0.5	1.2	0.7
BG55	1.7	—	2.3	—

Mass stated "with top-cover" includes mass of auxiliary table.



# INERTIA

Inertia of the slide block and ball screw of BG type are shown in Table I-5.

Table I-5 Inertia

unit / kg·m<sup>2</sup>

part number	rail length mm-7	without top-cover				with top-cover				rail length mm
		long block		short block		long block		short block		
		1block A	2block B	1block C	2block D	1block A	2block B	1block C	2block D	
BG2001	100	1.34 × 10 <sup>-7</sup>	1.36 × 10 <sup>-7</sup>	—	—	1.36 × 10 <sup>-7</sup>	1.40 × 10 <sup>-7</sup>	—	—	100
	150	1.83 × 10 <sup>-7</sup>	1.85 × 10 <sup>-7</sup>	—	—	1.85 × 10 <sup>-7</sup>	1.89 × 10 <sup>-7</sup>	—	—	150
	200	2.33 × 10 <sup>-7</sup>	2.35 × 10 <sup>-7</sup>	—	—	2.35 × 10 <sup>-7</sup>	2.39 × 10 <sup>-7</sup>	—	—	200
BG2005	100	1.76 × 10 <sup>-7</sup>	2.21 × 10 <sup>-7</sup>	—	—	2.00 × 10 <sup>-7</sup>	2.69 × 10 <sup>-7</sup>	—	—	100
	150	2.26 × 10 <sup>-7</sup>	2.70 × 10 <sup>-7</sup>	—	—	2.50 × 10 <sup>-7</sup>	3.18 × 10 <sup>-7</sup>	—	—	150
	200	2.76 × 10 <sup>-7</sup>	3.20 × 10 <sup>-7</sup>	—	—	3.00 × 10 <sup>-7</sup>	3.68 × 10 <sup>-7</sup>	—	—	200
BG2602	150	6.08 × 10 <sup>-7</sup>	6.26 × 10 <sup>-7</sup>	—	—	6.16 × 10 <sup>-7</sup>	6.40 × 10 <sup>-7</sup>	—	—	150
	200	7.65 × 10 <sup>-7</sup>	7.83 × 10 <sup>-7</sup>	—	—	7.72 × 10 <sup>-7</sup>	7.97 × 10 <sup>-7</sup>	—	—	200
	250	9.22 × 10 <sup>-7</sup>	9.39 × 10 <sup>-7</sup>	—	—	9.29 × 10 <sup>-7</sup>	9.54 × 10 <sup>-7</sup>	—	—	250
	300	1.08 × 10 <sup>-6</sup>	1.10 × 10 <sup>-6</sup>	—	—	1.09 × 10 <sup>-6</sup>	1.11 × 10 <sup>-6</sup>	—	—	300
BG2605	150	6.99 × 10 <sup>-7</sup>	8.07 × 10 <sup>-7</sup>	—	—	7.44 × 10 <sup>-7</sup>	8.98 × 10 <sup>-7</sup>	—	—	150
	200	8.56 × 10 <sup>-7</sup>	9.63 × 10 <sup>-7</sup>	—	—	9.01 × 10 <sup>-7</sup>	1.05 × 10 <sup>-6</sup>	—	—	200
	250	1.01 × 10 <sup>-6</sup>	1.12 × 10 <sup>-6</sup>	—	—	1.06 × 10 <sup>-6</sup>	1.21 × 10 <sup>-6</sup>	—	—	250
	300	1.17 × 10 <sup>-6</sup>	1.28 × 10 <sup>-6</sup>	—	—	1.21 × 10 <sup>-6</sup>	1.37 × 10 <sup>-6</sup>	—	—	300
BG3305	150	1.64 × 10 <sup>-6</sup>	—	1.56 × 10 <sup>-6</sup>	1.64 × 10 <sup>-6</sup>	1.71 × 10 <sup>-6</sup>	—	1.60 × 10 <sup>-6</sup>	1.71 × 10 <sup>-6</sup>	150
	200	2.02 × 10 <sup>-6</sup>	—	1.94 × 10 <sup>-6</sup>	2.03 × 10 <sup>-6</sup>	2.09 × 10 <sup>-6</sup>	—	1.98 × 10 <sup>-6</sup>	2.10 × 10 <sup>-6</sup>	200
	300	2.79 × 10 <sup>-6</sup>	2.99 × 10 <sup>-6</sup>	2.71 × 10 <sup>-6</sup>	2.79 × 10 <sup>-6</sup>	2.86 × 10 <sup>-6</sup>	3.13 × 10 <sup>-6</sup>	2.75 × 10 <sup>-6</sup>	2.86 × 10 <sup>-6</sup>	300
	400	3.55 × 10 <sup>-6</sup>	3.75 × 10 <sup>-6</sup>	3.48 × 10 <sup>-6</sup>	3.56 × 10 <sup>-6</sup>	3.62 × 10 <sup>-6</sup>	3.89 × 10 <sup>-6</sup>	3.51 × 10 <sup>-6</sup>	3.63 × 10 <sup>-6</sup>	400
	500	4.32 × 10 <sup>-6</sup>	4.52 × 10 <sup>-6</sup>	4.24 × 10 <sup>-6</sup>	4.32 × 10 <sup>-6</sup>	4.39 × 10 <sup>-6</sup>	4.66 × 10 <sup>-6</sup>	4.28 × 10 <sup>-6</sup>	4.39 × 10 <sup>-6</sup>	500
	600	5.08 × 10 <sup>-6</sup>	5.28 × 10 <sup>-6</sup>	5.01 × 10 <sup>-6</sup>	5.09 × 10 <sup>-6</sup>	5.15 × 10 <sup>-6</sup>	5.42 × 10 <sup>-6</sup>	5.04 × 10 <sup>-6</sup>	5.16 × 10 <sup>-6</sup>	600
BG3310	150	2.19 × 10 <sup>-6</sup>	—	1.88 × 10 <sup>-6</sup>	2.21 × 10 <sup>-6</sup>	2.47 × 10 <sup>-6</sup>	—	2.02 × 10 <sup>-6</sup>	2.49 × 10 <sup>-6</sup>	150
	200	2.57 × 10 <sup>-6</sup>	—	2.27 × 10 <sup>-6</sup>	2.59 × 10 <sup>-6</sup>	2.85 × 10 <sup>-6</sup>	—	2.40 × 10 <sup>-6</sup>	2.87 × 10 <sup>-6</sup>	200
	300	3.34 × 10 <sup>-6</sup>	4.14 × 10 <sup>-6</sup>	3.03 × 10 <sup>-6</sup>	3.36 × 10 <sup>-6</sup>	3.61 × 10 <sup>-6</sup>	4.69 × 10 <sup>-6</sup>	3.17 × 10 <sup>-6</sup>	3.64 × 10 <sup>-6</sup>	300
	400	4.10 × 10 <sup>-6</sup>	4.90 × 10 <sup>-6</sup>	3.80 × 10 <sup>-6</sup>	4.12 × 10 <sup>-6</sup>	4.38 × 10 <sup>-6</sup>	5.46 × 10 <sup>-6</sup>	3.94 × 10 <sup>-6</sup>	4.40 × 10 <sup>-6</sup>	400
	500	4.87 × 10 <sup>-6</sup>	5.67 × 10 <sup>-6</sup>	4.56 × 10 <sup>-6</sup>	4.89 × 10 <sup>-6</sup>	5.15 × 10 <sup>-6</sup>	6.22 × 10 <sup>-6</sup>	4.70 × 10 <sup>-6</sup>	5.17 × 10 <sup>-6</sup>	500
	600	5.63 × 10 <sup>-6</sup>	6.43 × 10 <sup>-6</sup>	5.33 × 10 <sup>-6</sup>	5.65 × 10 <sup>-6</sup>	5.91 × 10 <sup>-6</sup>	6.99 × 10 <sup>-6</sup>	5.47 × 10 <sup>-6</sup>	5.93 × 10 <sup>-6</sup>	600
BG4610	340	1.79 × 10 <sup>-5</sup>	2.02 × 10 <sup>-5</sup>	1.69 × 10 <sup>-5</sup>	1.82 × 10 <sup>-5</sup>	1.87 × 10 <sup>-5</sup>	2.17 × 10 <sup>-5</sup>	1.74 × 10 <sup>-5</sup>	1.92 × 10 <sup>-5</sup>	340
	440	2.18 × 10 <sup>-5</sup>	2.41 × 10 <sup>-5</sup>	2.08 × 10 <sup>-5</sup>	2.20 × 10 <sup>-5</sup>	2.25 × 10 <sup>-5</sup>	2.56 × 10 <sup>-5</sup>	2.13 × 10 <sup>-5</sup>	2.31 × 10 <sup>-5</sup>	440
	540	2.57 × 10 <sup>-5</sup>	2.79 × 10 <sup>-5</sup>	2.46 × 10 <sup>-5</sup>	2.59 × 10 <sup>-5</sup>	2.64 × 10 <sup>-5</sup>	2.95 × 10 <sup>-5</sup>	2.52 × 10 <sup>-5</sup>	2.69 × 10 <sup>-5</sup>	540
	640	2.95 × 10 <sup>-5</sup>	3.18 × 10 <sup>-5</sup>	2.85 × 10 <sup>-5</sup>	2.98 × 10 <sup>-5</sup>	3.03 × 10 <sup>-5</sup>	3.33 × 10 <sup>-5</sup>	2.90 × 10 <sup>-5</sup>	3.08 × 10 <sup>-5</sup>	640
	740	3.34 × 10 <sup>-5</sup>	3.57 × 10 <sup>-5</sup>	3.24 × 10 <sup>-5</sup>	3.37 × 10 <sup>-5</sup>	3.42 × 10 <sup>-5</sup>	3.72 × 10 <sup>-5</sup>	3.29 × 10 <sup>-5</sup>	3.47 × 10 <sup>-5</sup>	740
	840	3.73 × 10 <sup>-5</sup>	3.96 × 10 <sup>-5</sup>	3.63 × 10 <sup>-5</sup>	3.75 × 10 <sup>-5</sup>	3.80 × 10 <sup>-5</sup>	4.11 × 10 <sup>-5</sup>	3.67 × 10 <sup>-5</sup>	3.83 × 10 <sup>-5</sup>	840
	940	4.12 × 10 <sup>-5</sup>	4.35 × 10 <sup>-5</sup>	4.02 × 10 <sup>-5</sup>	4.14 × 10 <sup>-5</sup>	4.19 × 10 <sup>-5</sup>	4.50 × 10 <sup>-5</sup>	4.06 × 10 <sup>-5</sup>	4.22 × 10 <sup>-5</sup>	940
	1,040	4.50 × 10 <sup>-5</sup>	4.74 × 10 <sup>-5</sup>	4.41 × 10 <sup>-5</sup>	4.53 × 10 <sup>-5</sup>	4.58 × 10 <sup>-5</sup>	4.88 × 10 <sup>-5</sup>	4.44 × 10 <sup>-5</sup>	4.61 × 10 <sup>-5</sup>	1,040
	1,140	4.89 × 10 <sup>-5</sup>	5.12 × 10 <sup>-5</sup>	4.79 × 10 <sup>-5</sup>	4.92 × 10 <sup>-5</sup>	4.97 × 10 <sup>-5</sup>	5.27 × 10 <sup>-5</sup>	4.83 × 10 <sup>-5</sup>	4.99 × 10 <sup>-5</sup>	1,140
	1,240	5.28 × 10 <sup>-5</sup>	5.51 × 10 <sup>-5</sup>	5.18 × 10 <sup>-5</sup>	5.30 × 10 <sup>-5</sup>	5.35 × 10 <sup>-5</sup>	5.66 × 10 <sup>-5</sup>	5.22 × 10 <sup>-5</sup>	5.38 × 10 <sup>-5</sup>	1,240
BG4620	340	2.47 × 10 <sup>-5</sup>	3.39 × 10 <sup>-5</sup>	2.07 × 10 <sup>-5</sup>	2.58 × 10 <sup>-5</sup>	2.78 × 10 <sup>-5</sup>	3.99 × 10 <sup>-5</sup>	2.27 × 10 <sup>-5</sup>	2.98 × 10 <sup>-5</sup>	340
	440	2.86 × 10 <sup>-5</sup>	3.77 × 10 <sup>-5</sup>	2.46 × 10 <sup>-5</sup>	2.96 × 10 <sup>-5</sup>	3.17 × 10 <sup>-5</sup>	4.38 × 10 <sup>-5</sup>	2.66 × 10 <sup>-5</sup>	3.37 × 10 <sup>-5</sup>	440
	540	3.25 × 10 <sup>-5</sup>	4.16 × 10 <sup>-5</sup>	2.84 × 10 <sup>-5</sup>	3.35 × 10 <sup>-5</sup>	3.55 × 10 <sup>-5</sup>	4.77 × 10 <sup>-5</sup>	3.05 × 10 <sup>-5</sup>	3.76 × 10 <sup>-5</sup>	540
	640	3.64 × 10 <sup>-5</sup>	4.55 × 10 <sup>-5</sup>	3.23 × 10 <sup>-5</sup>	3.74 × 10 <sup>-5</sup>	3.94 × 10 <sup>-5</sup>	5.16 × 10 <sup>-5</sup>	3.44 × 10 <sup>-5</sup>	4.14 × 10 <sup>-5</sup>	640
	740	4.03 × 10 <sup>-5</sup>	4.94 × 10 <sup>-5</sup>	3.62 × 10 <sup>-5</sup>	4.13 × 10 <sup>-5</sup>	4.33 × 10 <sup>-5</sup>	5.55 × 10 <sup>-5</sup>	3.82 × 10 <sup>-5</sup>	4.53 × 10 <sup>-5</sup>	740
	840	4.41 × 10 <sup>-5</sup>	5.34 × 10 <sup>-5</sup>	4.02 × 10 <sup>-5</sup>	4.51 × 10 <sup>-5</sup>	4.71 × 10 <sup>-5</sup>	5.93 × 10 <sup>-5</sup>	4.17 × 10 <sup>-5</sup>	4.82 × 10 <sup>-5</sup>	840
	940	4.80 × 10 <sup>-5</sup>	5.72 × 10 <sup>-5</sup>	4.41 × 10 <sup>-5</sup>	4.90 × 10 <sup>-5</sup>	5.09 × 10 <sup>-5</sup>	6.32 × 10 <sup>-5</sup>	4.56 × 10 <sup>-5</sup>	5.21 × 10 <sup>-5</sup>	940
	1,040	5.19 × 10 <sup>-5</sup>	6.11 × 10 <sup>-5</sup>	4.80 × 10 <sup>-5</sup>	5.29 × 10 <sup>-5</sup>	5.48 × 10 <sup>-5</sup>	6.71 × 10 <sup>-5</sup>	4.95 × 10 <sup>-5</sup>	5.59 × 10 <sup>-5</sup>	1,040
	1,140	5.57 × 10 <sup>-5</sup>	6.50 × 10 <sup>-5</sup>	5.18 × 10 <sup>-5</sup>	5.68 × 10 <sup>-5</sup>	5.87 × 10 <sup>-5</sup>	7.09 × 10 <sup>-5</sup>	5.34 × 10 <sup>-5</sup>	5.98 × 10 <sup>-5</sup>	1,140
	1,240	5.96 × 10 <sup>-5</sup>	6.89 × 10 <sup>-5</sup>	5.57 × 10 <sup>-5</sup>	6.06 × 10 <sup>-5</sup>	6.26 × 10 <sup>-5</sup>	7.48 × 10 <sup>-5</sup>	5.72 × 10 <sup>-5</sup>	6.37 × 10 <sup>-5</sup>	1,240
BG5520	980	1.46 × 10 <sup>-4</sup>	1.64 × 10 <sup>-4</sup>	—	—	1.52 × 10 <sup>-4</sup>	1.76 × 10 <sup>-4</sup>	—	—	980
	1,080	1.59 × 10 <sup>-4</sup>	1.76 × 10 <sup>-4</sup>	—	—	1.65 × 10 <sup>-4</sup>	1.88 × 10 <sup>-4</sup>	—	—	1,080
	1,180	1.71 × 10 <sup>-4</sup>	1.88 × 10 <sup>-4</sup>	—	—	1.77 × 10 <sup>-4</sup>	2.00 × 10 <sup>-4</sup>	—	—	1,180
	1,280	1.83 × 10 <sup>-4</sup>	2.00 × 10 <sup>-4</sup>	—	—	1.89 × 10 <sup>-4</sup>	2.12 × 10 <sup>-4</sup>	—	—	1,280
	1,380	1.95 × 10 <sup>-4</sup>	2.13 × 10 <sup>-4</sup>	—	—	2.01 × 10 <sup>-4</sup>	2.25 × 10 <sup>-4</sup>	—	—	1,380





## RIGIDITY

By utilizing four-point contact structure, the BG type provides extremely high rigidity. Figure I-6 shows deflection of each size of long block against radial load. Table I-6. shows the geometrical moment inertia of guide rails.

Figure I-6 Block Deflection against Radial Load

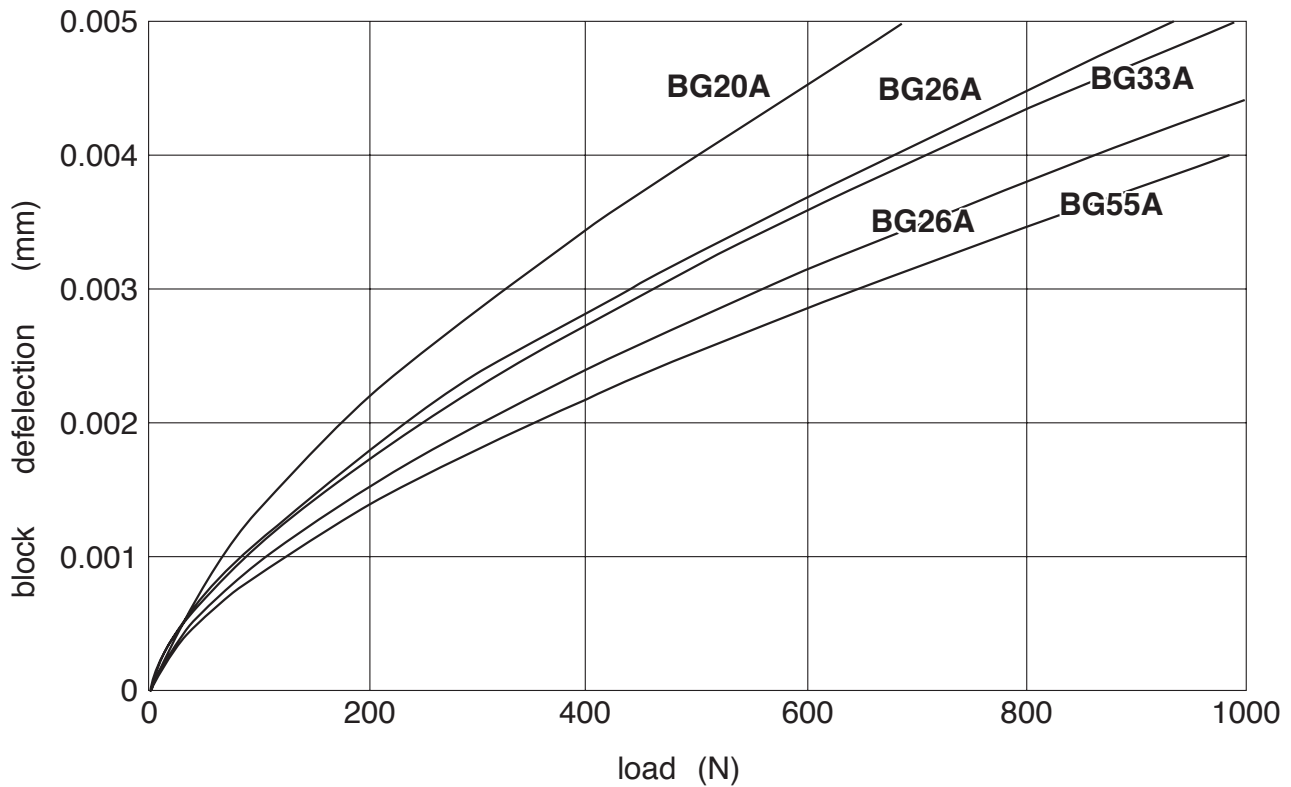
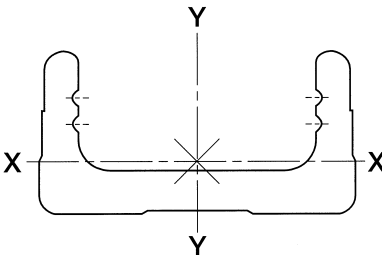

Table I-6 Geometrical Moment Inertia of Guide Rails

	part number	geometrical moment inertia (mm <sup>4</sup> )		mass (kg/100mm)
		IX(X Axis)	IY(Y Axis)	
	BG20	$6.50 \times 10^3$	$6.00 \times 10^4$	0.25
	BG26	$1.69 \times 10^4$	$1.47 \times 10^5$	0.38
	BG33	$5.11 \times 10^4$	$3.42 \times 10^5$	0.60
	BG46	$2.42 \times 10^5$	$1.49 \times 10^6$	1.24
	BG55	$2.29 \times 10^5$	$2.28 \times 10^6$	1.50



## ACCURACY

Table I-7 shows accuracy of BG type.

Table I-7 Accuracy

part number	rail length	positioning repeatability $\mu\text{m}$		positioning accuracy $\mu\text{m}$		running parallelism $\mu\text{m}$		backlash $\mu\text{m}$		※starting torque N · m			
		high	precision	high	precision	high	precision	high	precision	high	precision		
BG 20	100	±3	±1	50	20	25	10	5	2	0.01	0.012		
	150												
	200												
BG 26	150	±3	±1	50	20	25	10	5	2	0.015	0.04		
	200												
	250												
	300												
BG 33	150	±3	±1	30	15	25	10	5	2	0.07	0.15		
	200												
	300			35	20								
	400			40	25								
	500			40	25								
	600		70	—	35	15	—					—	
BG 46	340	±3	±1	35	20	35	15	5	2	0.10	0.15		
	440												
	540			40	25								
	640			50	30							40	20
	740			50	30							40	20
	840		—	—	80	50	—				—	—	
	940												
	1,040												
	1,140				100								
	1,240												
BG 55	980	±3	±1	80	35	50	25	5	2	0.12	0.17		
	1,080												
	1,180			40	30		0.20						
	1,280		100	—	—	—	—						
	1,380												

Above values are measured in conditions using our selected motors.

※Above specifications are based on using NB standard grease. other grease may cause deviations.



## Positioning Repeatability:

Establish an arbitrary point. From one end, position the inner block at this point and measure the stop position. Repeat the positioning and measurement process 7 times. Repeat the same process with respect to the established set point at the midpoint and near both ends of travel. Take the maximum measurement and divide the maximum difference by 2 and indicate it with either a positive or negative sign as the test results.

Positioning Repeatability=

$$\pm 1/2\{(\text{Maximum value of } \ell_n) - (\text{Minimum value of } \ell_n)\}$$

## Positioning Accuracy:

Positioning is performed in only one direction and the resulting position is set as the reference measurement point. Calculate the difference between the length of actual travel and the commanded travel length. Continuing in the same direction (without returning to the start point) repeat this process randomly several times until reaching limit of full stroke. Express the accuracy by the absolute maximum difference.

$$\text{Positioning accuracy} = (\Delta \ell_n)_{\text{max}}$$

## Running Parallelism:

Making sure that the surface plate is absolutely flat. Indicator placed on the center of block, run the block over the entire length of travel and use the maximum difference in readings as the test results.

## Backlash:

Use the feed screw to move the block a little. Take the test indicator reading and make it the reference point. While in this position, load the block in the same direction without using the feed screw. Release the load and read the return. Calculate the difference between the reference point. Repeat the same process at the midpoint and near both ends. Use the maximum difference as the test result.

$$\text{Backlash} = (\Delta \ell)_{\text{max}}$$

Figure I-7 Positioning Repeatability

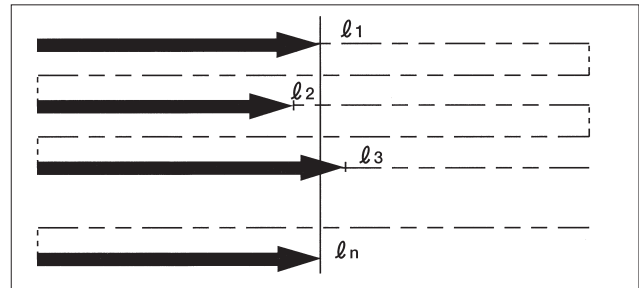

Figure I-8 Positioning Accuracy

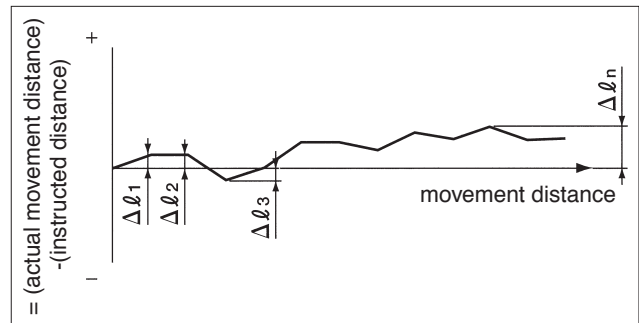

Figure I-9 Running Parallelism

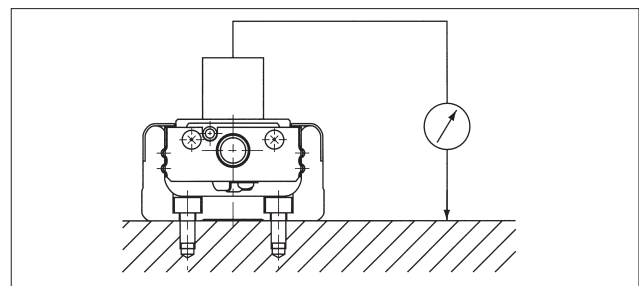
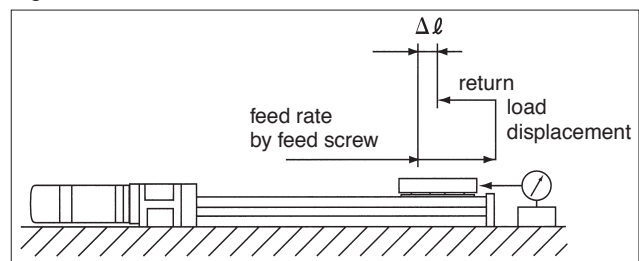

Figure I-10 Backlash





## RATED LIFE

To obtain the rated life of the BG type, calculate the rated life of the guide section, and ball screw section or support section. Use the minimum value as the rated life of the BG type. Use the following equation for calculating the rated life.

### A. Life of Guide portion

Use the following formula for calculating the rated life of Guide portion.

$$L_G = \left( \frac{f_c}{f_w} \cdot \frac{C}{P_T} \right)^3 \cdot 50 \dots \dots \dots (1)$$

$L_G$  : Rated life (km)  $f_c$  : contact coefficient (see Table I-8)  
 $f_w$  : load coefficient (see Table I-9)  $C$  : basic dynamic load rating (N)  
 $P_T$  : calculated load applied to one block (N)

#### A.1. Calculation of $P_T$

Before calculating the rated life using the equation (1), the calculated load applied to one block ( $P_T$ ) needs to be obtained in consideration of the moment load, etc. that will be actually applied.

For rapidly-accelerating or short stroke motion,  $P_T$  needs to be calculated with acceleration taken into consideration. The calculation of this acceleration will be carried out for the mass applied to BG.

Obtain the calculated load during uniform motion, accelerating, and decelerating, and use the average value of the three as  $P_T$ .

For the calculation of  $P_T$ , select an appropriate equation depending on the installation conditions of the guide.

It is also possible to calculate  $P_T$  without including the effect of acceleration by using the equation " $P_T = P_{TC}$ " (see the equations (2), (5), and (8)). In this case, however, the obtained value is an approximate one, so a selection with sufficient margin is recommended.

Table I-8 Contact Coefficient ( $f_c$ )

number of blocks used in close contact on one axis	contact coefficient ( $f_c$ )
1	1.0
2	0.81

Table I-9 Load Coefficient ( $f_w$ )

use conditions		load coefficient ( $f_w$ )
vibration, impact	velocity	
none	15 m/min. or less	1.0~1.5
low	60 m/min. or less	1.5~2.0
high	60 m/min. or more	2.0~3.5

Table I-10 Moment Equivalent Coefficient

	$E_p(E2p)$	$E_y(E2p)$	$E_r(E2r)$
BG20**A	$2.25 \times 10^{-1}$	$1.89 \times 10^{-1}$	$7.84 \times 10^{-2}$
BG20**B	$3.98 \times 10^{-2}$	$3.34 \times 10^{-2}$	$3.92 \times 10^{-2}$
BG26**A	$1.51 \times 10^{-1}$	$1.27 \times 10^{-1}$	$5.88 \times 10^{-2}$
BG26**B	$2.72 \times 10^{-2}$	$2.28 \times 10^{-2}$	$2.94 \times 10^{-2}$
BG33**A	$1.26 \times 10^{-1}$	$1.06 \times 10^{-1}$	$4.55 \times 10^{-2}$
BG33**B	$2.20 \times 10^{-2}$	$1.84 \times 10^{-2}$	$2.27 \times 10^{-2}$
BG33**C	$2.31 \times 10^{-1}$	$1.94 \times 10^{-1}$	$4.55 \times 10^{-2}$
BG33**D	$3.09 \times 10^{-2}$	$2.59 \times 10^{-2}$	$2.27 \times 10^{-2}$
BG46**A	$8.39 \times 10^{-2}$	$7.04 \times 10^{-2}$	$3.17 \times 10^{-2}$
BG46**B	$1.56 \times 10^{-2}$	$1.31 \times 10^{-2}$	$1.59 \times 10^{-2}$
BG46**C	$1.39 \times 10^{-1}$	$1.17 \times 10^{-1}$	$3.17 \times 10^{-2}$
BG46**D	$2.15 \times 10^{-2}$	$1.81 \times 10^{-1}$	$1.59 \times 10^{-2}$
BG55**A	$6.80 \times 10^{-2}$	$5.71 \times 10^{-2}$	$2.74 \times 10^{-2}$
BG55**B	$1.35 \times 10^{-2}$	$1.14 \times 10^{-2}$	$1.37 \times 10^{-2}$

\* For the two-block specifications, the coefficient is that measured when the two blocks are in close contact.



## A.1.a P<sub>T</sub> for Horizontal Move (Horizontal Mounting)

i )during uniform motion(P<sub>TC</sub>)

$$P_{TC} = \frac{1}{n} \cdot W + Ep \cdot Mp_L + Ey \cdot My_L + Er \cdot Mr_L \dots\dots\dots(2)$$

ii )during accelerating(P<sub>Ta</sub>)

$$P_{Ta} = \frac{1}{n} \cdot W + Ep(Mp_L + m \cdot \alpha_a \cdot Z) + Ey(My_L + m \cdot \alpha_a \cdot X) + Er \cdot Mr_L \dots\dots\dots(3)$$

Note that the values of (Mp<sub>L</sub> + m · α<sub>a</sub> · Z) and (My<sub>L</sub> + m · α<sub>a</sub> · X) will be treated as 0 (zero) when the calculated value is negative.

iii )during decelerating(P<sub>Td</sub>)

$$P_{Td} = \frac{1}{n} \cdot W + Ep(Mp_L + m \cdot -\alpha_d \cdot Z) + Ey(My_L + m \cdot -\alpha_d \cdot X) + Er \cdot Mr_L \dots\dots\dots(4)$$

Note that the values of (Mp<sub>L</sub> + m · -α<sub>d</sub> · Z) and (My<sub>L</sub> + m · -α<sub>d</sub> · X) will be treated as 0 (zero) when the calculated value is negative.

Figure I-11

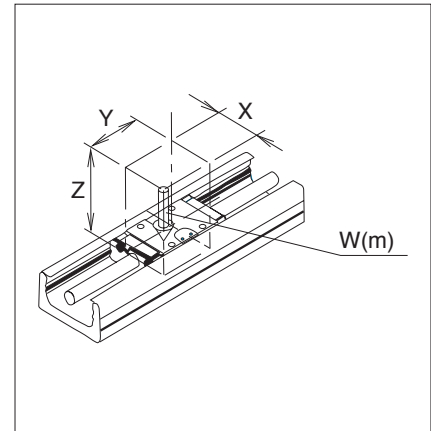

## A.1.b P<sub>T</sub> for Horizontal Move (Wall Mounting)

i )during uniform motion(P<sub>TC</sub>)

$$P_{TC} = \frac{1}{1.19 \cdot n} \cdot W + Ep \cdot Mp_L + Ey \cdot My_L + Er \cdot Mr_L \dots\dots\dots(5)$$

ii )during accelerating(P<sub>Ta</sub>)

$$P_{Ta} = \frac{1}{1.19 \cdot n} \cdot W + Ep(Mp_L + m \cdot \alpha_d \cdot Z) + Ey(My_L + m \cdot \alpha_d \cdot X) + Er \cdot Mr_L \dots\dots\dots(6)$$

Note that the values of (Mp<sub>L</sub> + m · α<sub>d</sub> · Z) and (My<sub>L</sub> + m · α<sub>d</sub> · X) will be treated as 0 (zero) when the calculated value is negative.

iii )during decelerating(P<sub>Td</sub>)

$$P_{Td} = \frac{1}{1.19 \cdot n} \cdot W + Ep(Mp_L + m \cdot -\alpha_d \cdot Z) + Ey(My_L + m \cdot -\alpha_d \cdot X) + Er \cdot Mr_L \dots\dots\dots(7)$$

Note that the values of (Mp<sub>L</sub> + m · -α<sub>d</sub> · Z) and (My<sub>L</sub> + m · -α<sub>d</sub> · X) will be treated as 0 (zero) when the calculated value is negative.

Figure I-12

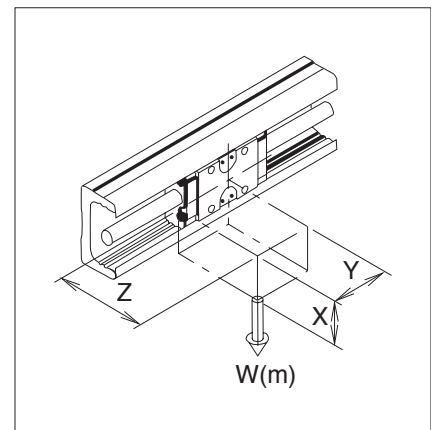



### A.1.c. P<sub>T</sub> for Vertical Move

i) during uniform motion (P<sub>Tc</sub>)

$$P_{Tc} = E_p \cdot M_{pL} + E_y \cdot M_{yL} + E_r \cdot M_{rL} \dots \dots \dots (8)$$

ii) during accelerating (P<sub>Ta</sub>)

$$P_{Ta} = E_p(M_{pL} + m \cdot \alpha_a \cdot Z) + E_y(M_{yL} + m \cdot \alpha_a \cdot X) + E_r \cdot M_{rL} \dots \dots \dots (9)$$

Note that the values of (M<sub>pL</sub> + m · α<sub>a</sub> · Z) and (M<sub>yL</sub> + m · α<sub>a</sub> · X) will be treated as 0 (zero) when the calculated value is negative.

iii) during decelerating (P<sub>Td</sub>)

$$P_{Td} = E_p(M_{pL} + m \cdot \alpha_d \cdot Z) + E_y(M_{yL} + m \cdot \alpha_d \cdot X) + E_r \cdot M_{rL} \dots \dots \dots (10)$$

Note that the values of (M<sub>pL</sub> + m · α<sub>d</sub> · Z) and (M<sub>yL</sub> + m · α<sub>d</sub> · X) will be treated as 0 (zero) when the calculated value is negative.

Figure I-13

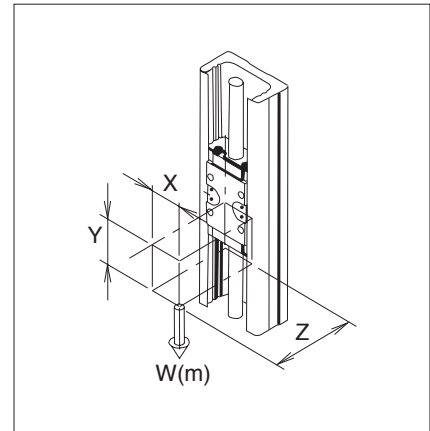

P<sub>Tc</sub>:calculated load applied to a block during uniform motion (N) P<sub>Ta</sub>:calculated load applied to a block during accelerating (N)  
P<sub>Td</sub>:calculated load applied to a block during decelerating (N) n:number of blocks of BG W:applied load (N) m:carrying mass (kg)  
α<sub>a</sub>:acceleration during accelerating (m/s<sup>2</sup>) α<sub>d</sub>:acceleration during decelerating (m/s<sup>2</sup>) X:distance between the center of BG and the center of the carrying mass (mm)  
Y:distance between the center of BG and the center of the carrying mass (mm) Z:distance between the center of BG ball screw and the center of the carrying mass (mm)  
E<sub>p</sub>:moment equivalent coefficient in the pitching direction (see Table I-10) E<sub>y</sub>:moment equivalent coefficient in the yawing direction (see Table I-10)  
E<sub>r</sub>:moment equivalent coefficient in the rolling direction (see Table I-10) M<sub>pL</sub>:loaded moment in the pitching direction (N · m)M<sub>pL</sub>=W · Z  
M<sub>yL</sub>:loaded moment in the yawing direction (N · m)M<sub>yL</sub>=W · X M<sub>rL</sub>:loaded moment in the rolling direction (N · m)M<sub>rL</sub>=W · Y \* See Fig.I-4 for the direction of moment.

A.1.d. Obtain the calculated load applied to a block (P<sub>T</sub>) by calculating the average load of each motion using an appropriate equation among those shown above according to the application.

$$P_T = \sqrt[3]{\frac{1}{S1+S2+S3} (P_{Ta}^3 \cdot S1 + P_{Tc}^3 \cdot S2 + P_{Td}^3 \cdot S3)} \dots \dots \dots (11)$$

P<sub>T</sub>:calculated load applied to one block (N)  
S1:travel distance during accelerating (mm) (see Table I-14)  
S2:travel distance during uniform motion (mm) (see Table I-14)  
S3:travel distance during decelerating (mm) (see Table I-14)  
P<sub>Ta</sub>:calculated load applied to one block during accelerating (N) : equation (3), (6), and (9)  
P<sub>Tc</sub>:calculated load applied to one block during uniform motion (N) : equation (2), (5), and (8)  
P<sub>Td</sub>:calculated load applied to one block during decelerating (N) : equation (4), (7), and (10)

Figure I-14

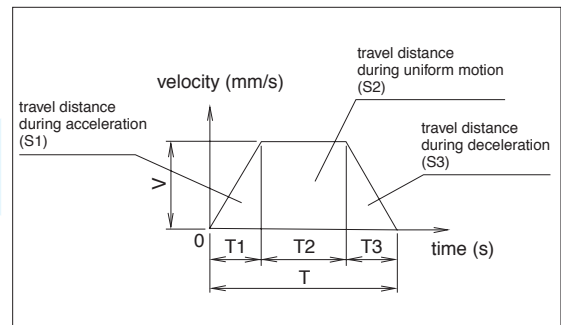

## B. Life of the Ball Screw and Support Bearing

The life of ball screws and support bearings can be calculated using a common equation, as shown below. Compare the dynamic load rating of the ball screw and the support bearing and apply smaller value for calculation.

$$L_a = \left( \frac{1}{f_w} \cdot \frac{C_a \text{ or } C_b}{P_a} \right)^3 \cdot \ell \dots \dots \dots (12)$$

L<sub>a</sub>:rated life (km) f<sub>w</sub>:load coefficient (see Table I-9)  
C<sub>a</sub>:basic dynamic load rating of the ball screw (N)  
C<sub>b</sub>:basic dynamic load rating of the support bearing (N)  
P<sub>a</sub>:axis-directional load (N) ℓ :ball screw lead (mm)

### B. 1. Calculation of P<sub>a</sub>

Before calculating the life using the equation (12), calculate P<sub>a</sub> with acceleration taken into consideration. Calculate the load in each axis direction during uniform motion, accelerating, and decelerating and the obtained value is used as P<sub>a</sub>.



## B.1.a For Horizontal Move

i ) during uniform motion(Pac)

$$P_{ac} = \mu \cdot W + F + fb \cdot n \dots \dots \dots (13)$$

ii )during accelerating(Paa)

$$P_{aa} = \mu \cdot W + F + fb \cdot n + (m + mb \cdot n) \alpha_a \dots \dots \dots (14)$$

iii) during decelerating(Pad)

$$P_{ad} = \mu \cdot W + F + fb \cdot n - (m + mb \cdot n) \alpha_d \dots \dots \dots (15)$$

## B.1.b For Vertical Move

i ) during uniform motion(Pac)

$$P_{ac} = (m + mb \cdot n)g + F + fb \cdot n \dots \dots \dots (16)$$

ii )during accelerating(Paa)

$$P_{aa} = (m + mb \cdot n)g + F + fb \cdot n + (m + mb \cdot n) \alpha_a \dots \dots \dots (17)$$

iii) during decelerating(Pad)

$$P_{ad} = (m + mb \cdot n)g + F + fb \cdot n - (m + mb \cdot n) \alpha_d \dots \dots \dots (18)$$

**B.1.c.** Obtain the average axis-directional load (Pa) using an appropriate formula among those shown above depending on the application.

$$P_a = \sqrt[3]{\frac{1}{S_1 + S_2 + S_3} (|P_{aa}|^3 \cdot S_1 + |P_{ac}|^3 \cdot S_2 + |P_{ad}|^3 \cdot S_3)} \dots \dots \dots (11)$$

- Pa: average axis-directional load (N)
- S1: travel distance during accelerating (mm) (see Table I-14)
- S2: travel distance during uniform motion (mm) (see Table I-14)
- S3: travel distance during decelerating (mm) (see Table I-14)
- Paa: axis-directional load during accelerating (N): formulas (14) and (17)
- Pac: axis-directional load during uniform motion (N): formulas (13) and (16)
- Pad: axis-directional load during decelerating (N): formulas (15) and (18)

Table I-11 Sliding Resistance (fb) of a Single Block (Seal Resistance)  
unit: N

	high class (H)	precision class (P)
<b>BG20</b>	2.3	4.9
<b>BG26</b>	5.4	9.8
<b>BG33</b>	4.4	10.2
<b>BG46</b>	7.4	13.3
<b>BG55</b>	9	16

- Pac: axis-directional load rating during uniform motion (N)
- Paa: axis-directional load rating during accelerating (N)
- Pad: axis-directional load rating during decelerating (N)
- μ: friction coefficient
- W: load applied to a block (N)
- F: external force (load) applied to the axis direction (N)
- fb: sliding resistance of a single block (N) (see Table I-11)
- n: number of blocks of BG
- m: carrying mass (kg)
- mb: mass of a block of BG (kg) (see Table I-4)
- αa: acceleration during accelerating (m/s<sup>2</sup>)
- αd: acceleration during decelerating (m/s<sup>2</sup>)



## LUBRICATION

- BG type contains a lithium-soap based grease. Apply similar grade of grease for the lubrication as required depending on your terms of operation.
- Use grease fitting to lubricate the guide block. For ball screw apply grease directly to surface of screw shaft.
- Unless otherwise instructed, a grease fitting is located as shown in Figure I-15.
- The greases can be changed to a high-function type by adding a special grease option code at the end of the part number. Please refer to Table I-12 for the type of the greases. Also refer to page Eng-20 for further detail of greases.

Table I-12 Applicable Greases

grease option code	features	product name
none (standard)		Multemp PS No.2 (KYODO YUSHI)
GK	urea-type low dust generation grease	K Grease
GU	urea-type low dust generation grease; low sliding resistance	KGU Grease
GL	lithium-type low dust generation grease	KGL Grease
GF	urea-type anti-fretting grease	KGF Grease

Figure I-15 Location of Grease Fitting

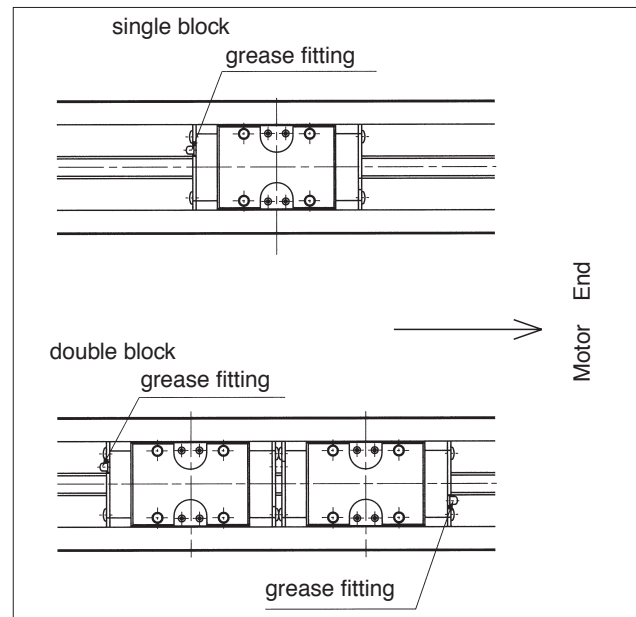

## OPERATING TEMPERATURE

- Resin parts are assembled in BG type. The recommended ambient working temperature is 80 °C or lower. Apply 55°C or lower for photo micro sensor option type.

## PRECAUTION FOR USE

- Handle as a precision component to avoid excessive vibration or shock. Rough handling will affect the smooth traveling and may reduce the precision performance and/or life of the BG type.
- DO NOT DISASSEMBLE. The accuracy of BG type is adjusted by the factory when it is assembled.
- Allow for extra stroke distance. If the guide block repeatedly collides with damper, it may cause damage.
- Depending upon the operating environment, dust and debris may contaminate BG type and disrupt the ideal ball circulation and operating performance.





## MOTOR BRACKET CONFIGURATIONS & APPLICABLE MOTORS

NB provides optional motor mount brackets to easily install most popular motors.

Table I-13 Applicable motors

Applicable motors			Part number	BG20	BG26	BG33	BG46	BG55	
AC Servo motor	MATSUSHITA ELECTRIC	MSMA3AZ	30W						
		MSMA5AZ	50W	A3	A3	A2	C0	—	
		MSMA01	100W						
		MSMA02	200W	—	—	—	A2	—	
		MSMA04	400W	—	—	—	A3	A2	
		MSMA08	750W	—	—	—	A3	A2	
	MITSUBISHI ELECTRIC	HC-AQ0135	10W						
		HC-AQ0235	20W	A8	A8	—	—	—	
		HC-AQ0335	30W						
		HC-KFS(MFS,PQ)053	50W	A1	A1	A1	B0	—	
		HC-KFS(MFS,PQ)13	100W						
		HC-KFS(MFS,PQ)23	200W	—	—	—	A1	A0	
		HC-KFS(MFS,PQ)43	400W	—	—	—	A4	A1	
		HC-KFS(MFS)73	750W	—	—	—	A4	A1	
		HA-FF053	50W	—	—	A3	A0	—	
		HA-FF13	100W	—	—	—	A0	—	
		HA-FF23	200W	—	—	—	A3	A2	
		HA-FF33	300W	—	—	—	A3	A2	
	YASUKAWA ELECTRIC	SGMM-A131*	10W						
		SGMM-A231*	20W	A9	A9	—	—	—	
		SGMM-A331*	30W						
		SGMAH-A3	30W						
		SGMAS(SGMAH)-A5	50W	A1	A1	A1	B0	—	
		SGMAS(SGMAH)-01	100W						
		SGMAS-C2	150W	—	—	—	A1	A0	
		SGMAS(SGMAH)-02	200W	—	—	—	A1	A0	
		SGMAS(SGMAH)-04	400W	—	—	—	A4	A1	
		SGMAS(SGMAH)-08	750W	—	—	—	A4	A1	
	SANYO ELECTRIC	Q1AA04003D	30W						
		Q1AA04005D	50W	A1	A1	A1	B0	—	
		Q1AA04010D	100W						
		Q1AA06020D	200W	—	—	—	A1	A0	
		Q1AA06040D	400W	—	—	—	A1	A0	
		Q1AA07075D	750W	—	—	—	A4	A1	
		Q2AA05005D	50W	—	—	A3	A0	—	
		Q2AA05010D	100W	—	—	—	A0	—	
		Q2AA07020D	200W	—	—	—	A3	A2	
		Q2AA07030D	300W	—	—	—	A3	A2	
		Q2AA07040D	400W	—	—	—	A3	A2	
		Q2AA08050D	500W	—	—	—	—	A3	
		Q2AA08075D	750W	—	—	—	—	A3	
		CHIBA PRECISION	EA-2151	6W	A4	—	—	—	—
EA-2169	10W								
EA-2565	12W		A7	A7	—	—	—		
EA-2580	20W								
Stepper motor	ORIENTAL MOTOR	UPD534M-A	—	A5	A5	—	—	—	
		PMU33AH	—	A6	A6	—	—	—	
		UPK(RK)54,AS4	—	A5	A5	B1	—	—	
		UPK(RK)56,AS6	—	—	—	A4	D0	—	
		UPK(RK)59,AS9	—	—	—	—	—	A4	
		PK26	—	—	—	A5	—	—	

NB can provide other motor mount brackets. Please contact your NB representative for details.

# BG20

Figures inside ( ) indicates mass of the motor mount adapter plate.

Motor Bracket A0

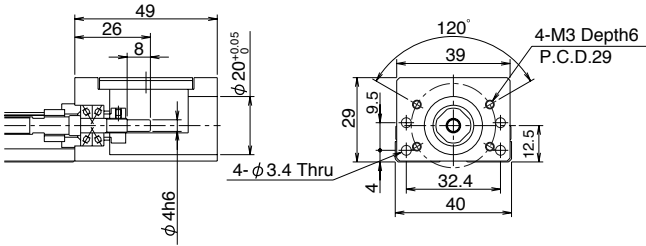

Motor Bracket A6 (Mass:10g)

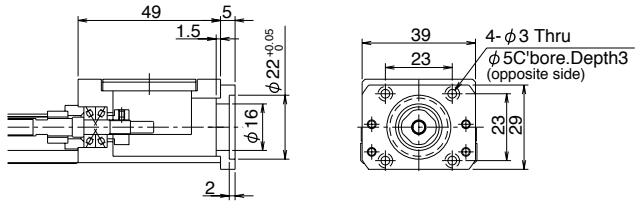

Motor Bracket A1 (Mass:38g)

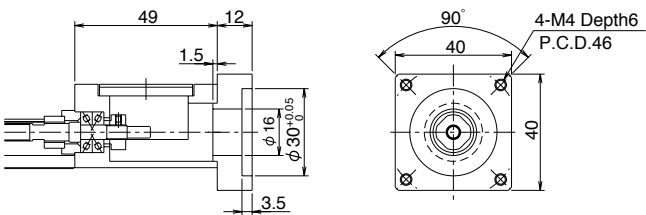

Motor Bracket A7 (Mass:8g)

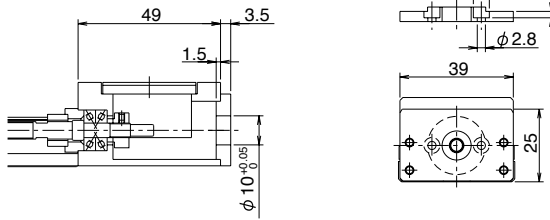

Motor Bracket A3 (Mass:39g)

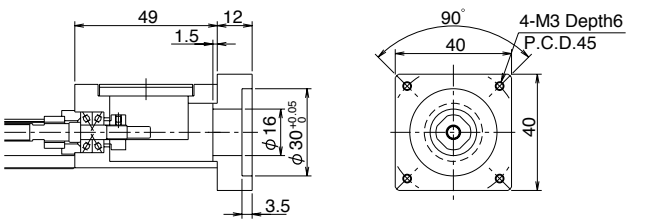

Motor Bracket A8 (Mass:12g)

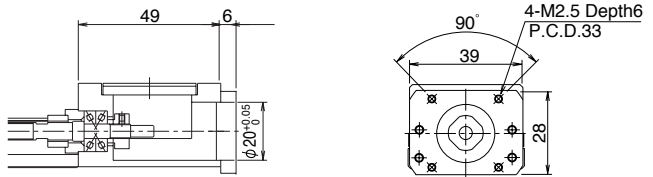

Motor Bracket A4 (Mass: 5g)

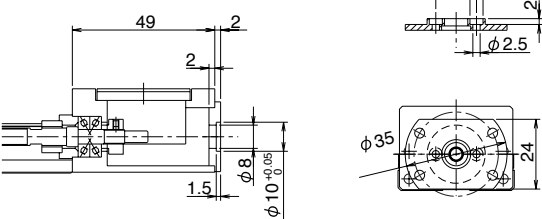

Motor Bracket A9 (Mass:14g)

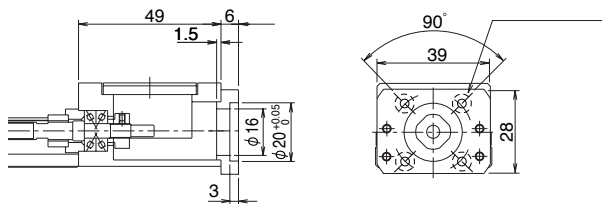

Motor Bracket A5 (Mass:26g)

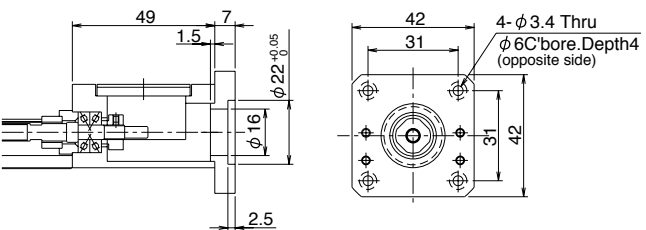

For configurations A4, A5, A6, A7 and A9, attach intermediate flange to motor first.



## BG26

Figures inside( ) indicates mass of the motor mount adapter plate.

Motor Bracket A0

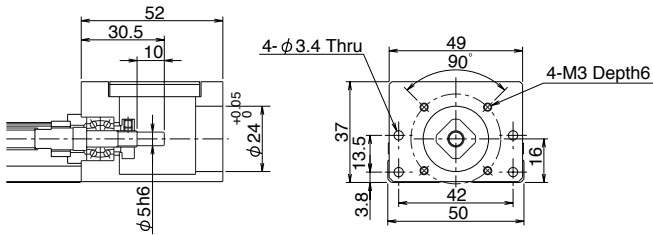

Motor Bracket A6 (Mass:16g)

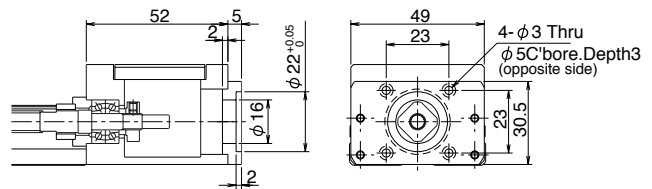

Motor Bracket A1 (Mass:28g)

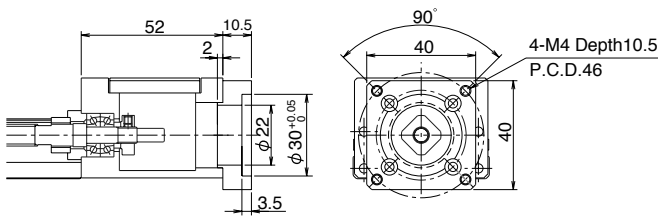

Motor Bracket A7 (Mass: 8g)

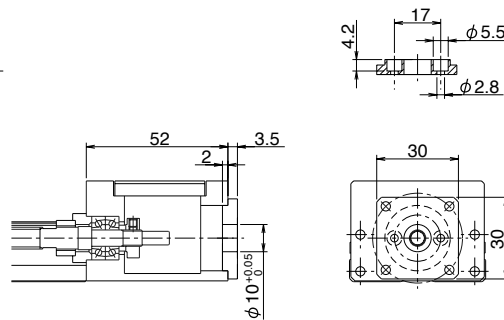

Motor Bracket A3 (Mass:24g)

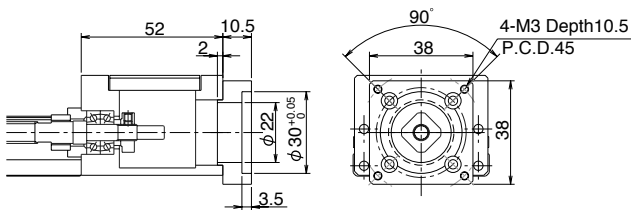

Motor Bracket A8 (Mass:21g)

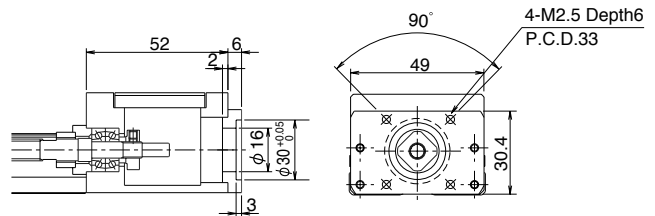

Motor Bracket A5 (Mass:32g)

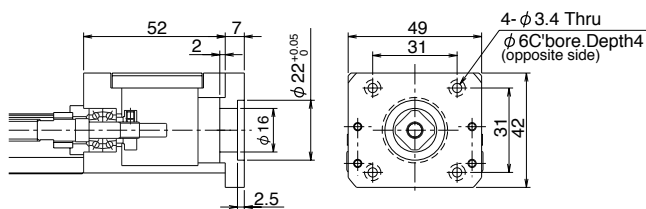

Motor Bracket A9 (Mass:21g)

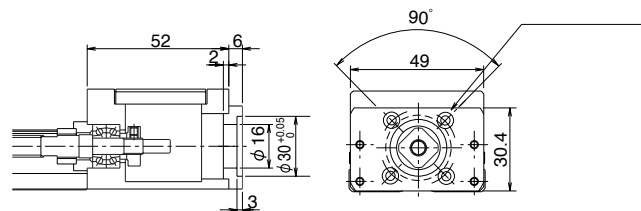

For configurations A4, A5, A6, A7 and A9, attach intermediate flange to motor first.

# BG33

Figures inside( ) indicates mass of the motor mount adapter plate.

Motor Bracket A0

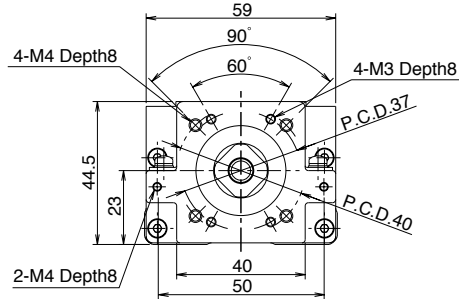
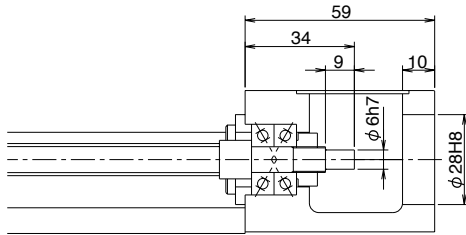

Motor Bracket A1 (Mass:66 g)

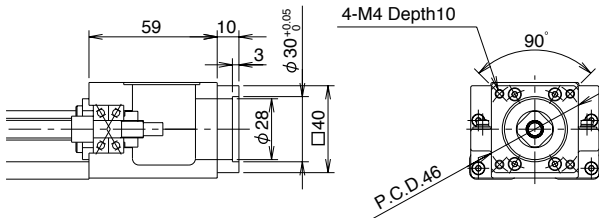

Motor Bracket A4 (Mass:212 g)

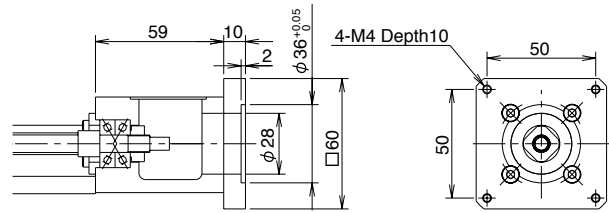

Motor Bracket A2 (Mass:67 g)

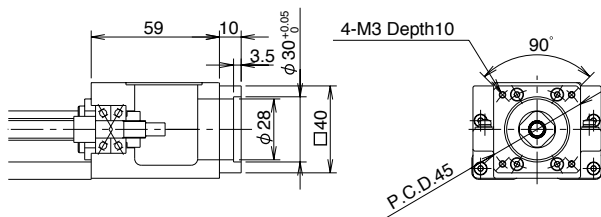

Motor Bracket A5 (Mass:125 g)

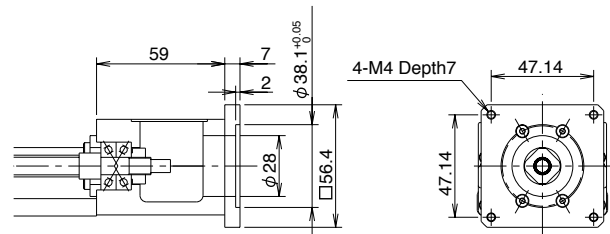

Motor Bracket A3 (Mass:133 g)

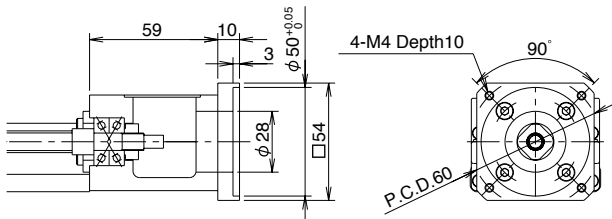

Motor Bracket B1 (Mass:111 g)

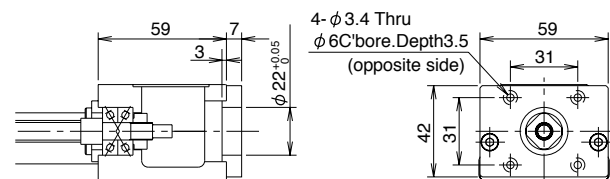

For configuration of B1, attach intermediate flange to motor first.



## BG46

Figures inside( ) indicates mass of the motor mount adapter plate.

Motor Bracket A0

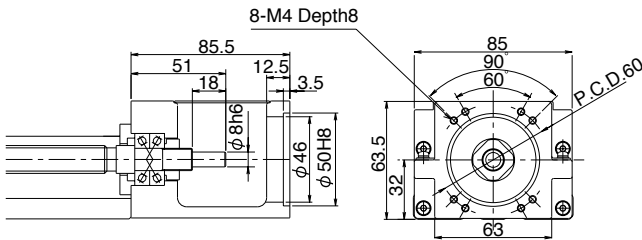

Motor Bracket A4(Mass:628 g)

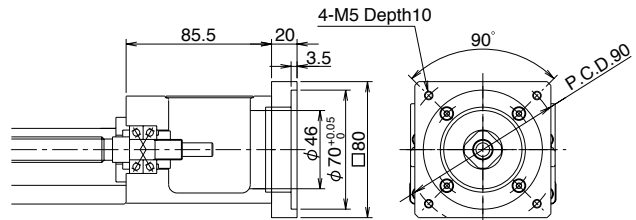

Motor Bracket A1 (Mass:103 g)

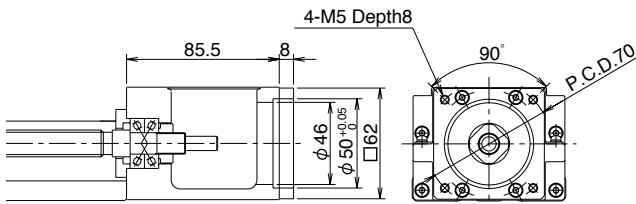

Motor Bracket B0

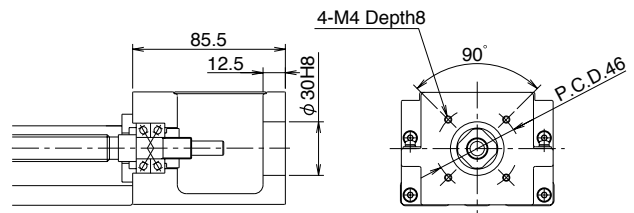

Motor Bracket A2 (Mass:106 g)

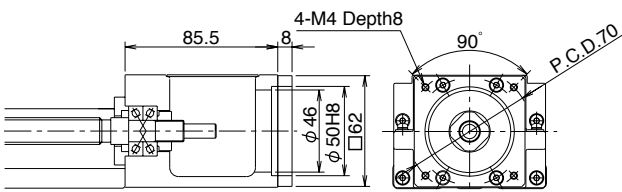

Motor Bracket C0

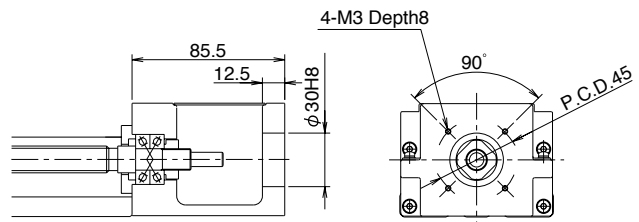

Motor Bracket A3 (Mass:448 g)

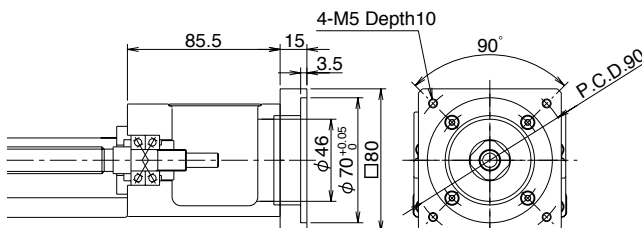

Motor Bracket D0

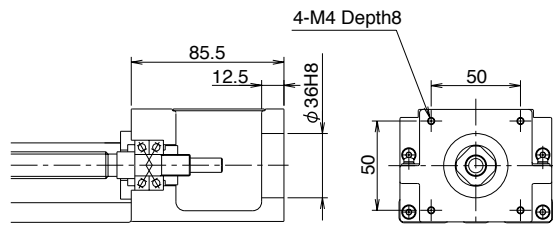

# BG55

Figures inside( ) indicates mass of the motor mount adapter plate.

Motor Bracket A0

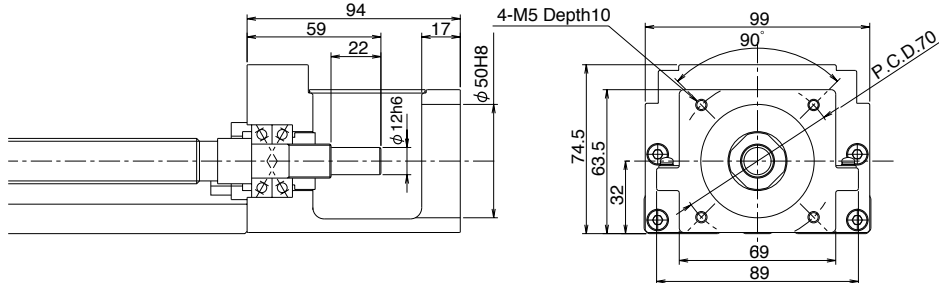

Motor Bracket A1 (Mass:329 g)

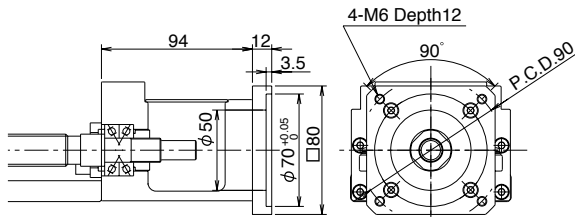

Motor Bracket A3 (Mass:399 g)

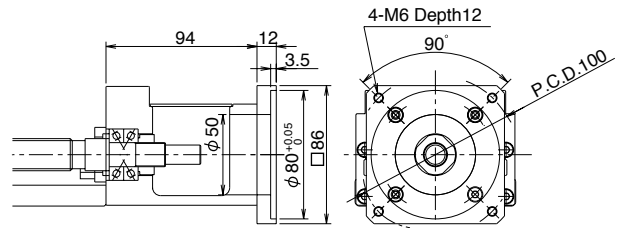

Motor Bracket A2 (Mass:333 g)

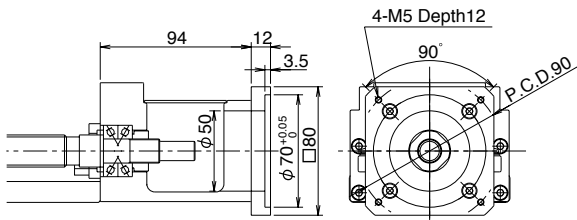

Motor Bracket A4 (Mass:449 g)

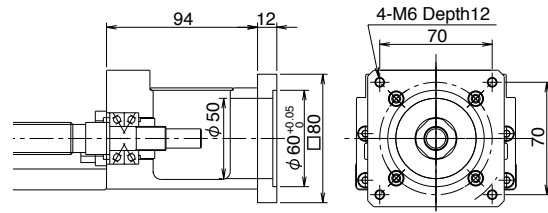



## EXPOSED BRACKET

For the BG type, Exposed brackets with the motor end of the ball screw shaft exposed are available. When using a motor unable to be mounted using a standard motor bracket or intermediate flange, make an original bracket and connect it to the exposed bracket.

### BG20 Exposed Bracket R0

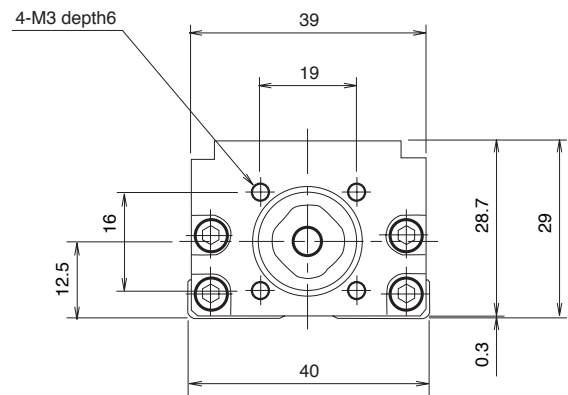
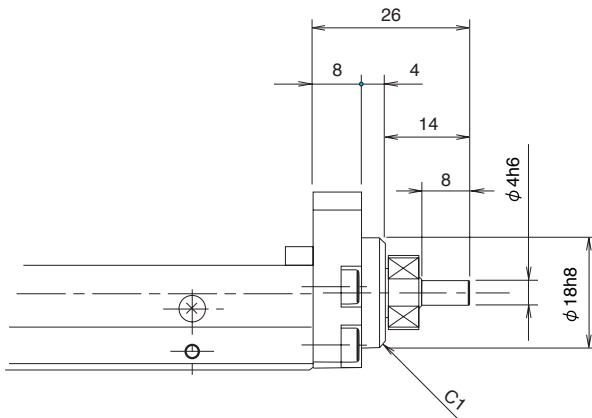

1. can be used for both with cover and sensor.
2. Mass is reduced 0.04kg from the value of Table I-3, page I-7.

### BG26 Exposed Bracket R0

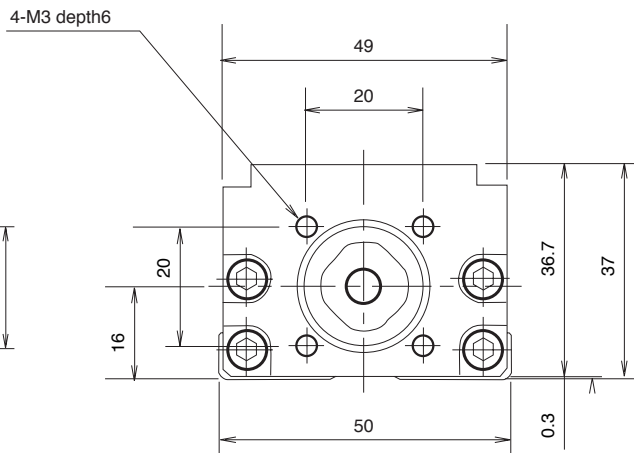
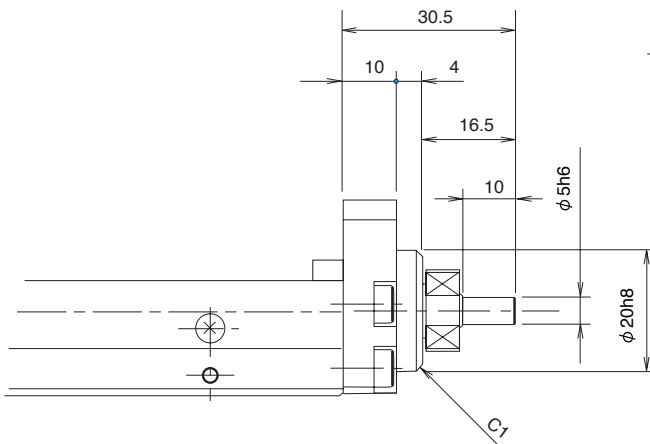

1. can be used for both with cover and sensor.
2. Mass is reduced 0.08kg from the value of Table I-3, page I-7.

## <BG33 Exposed Bracket R0>

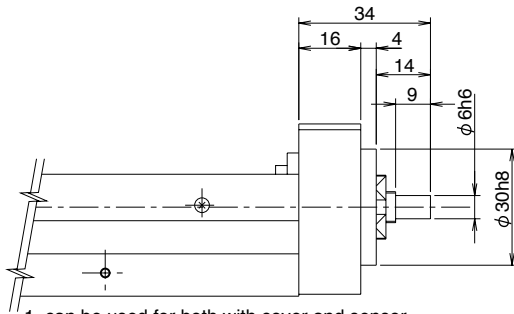

1. can be used for both with cover and sensor.
2. Mass is reduced 0.1kg from the value of Table I-3, page I-7.

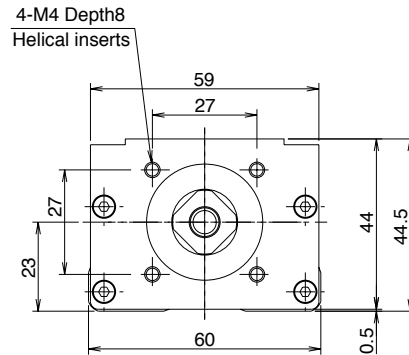

## <BG46 Exposed Bracket R0>

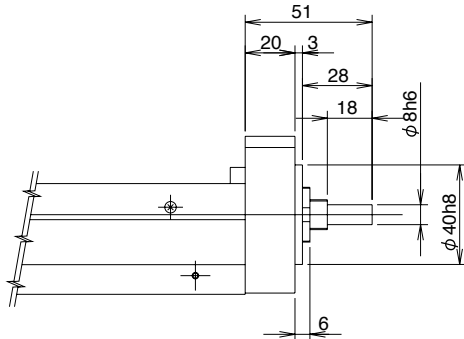

1. can be used for both with cover and sensor.
2. Mass is reduced 0.3kg from the value of Table I-3, page I-7.

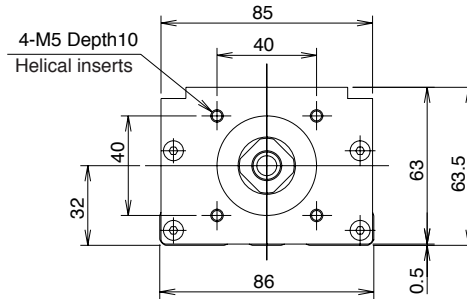





## <BG55 Exposed Bracket R0>

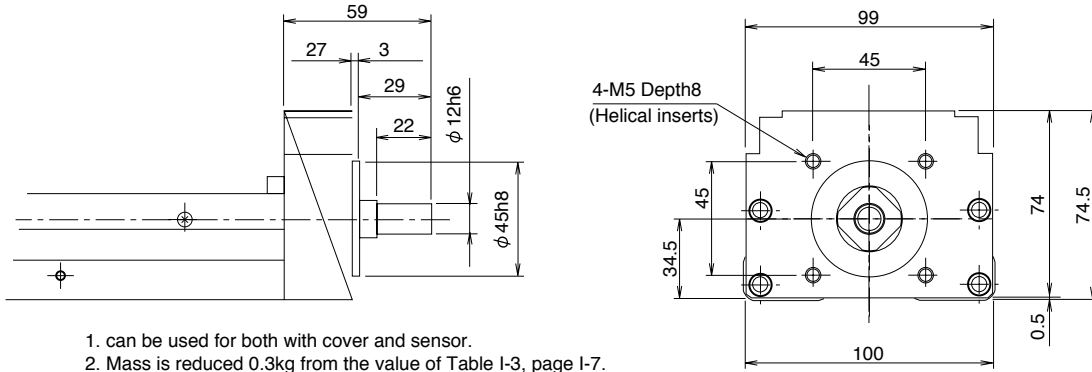

1. can be used for both with cover and sensor.
2. Mass is reduced 0.3kg from the value of Table I-3, page I-7.



## RETURN PULLEY UNIT

Return pulley units in which a motor is connected with a timing belt are available for BG type. Its return structure allows the reduction of total length (available for BG33 and BG46 types).

### <BG33 Return Pulley Unit>

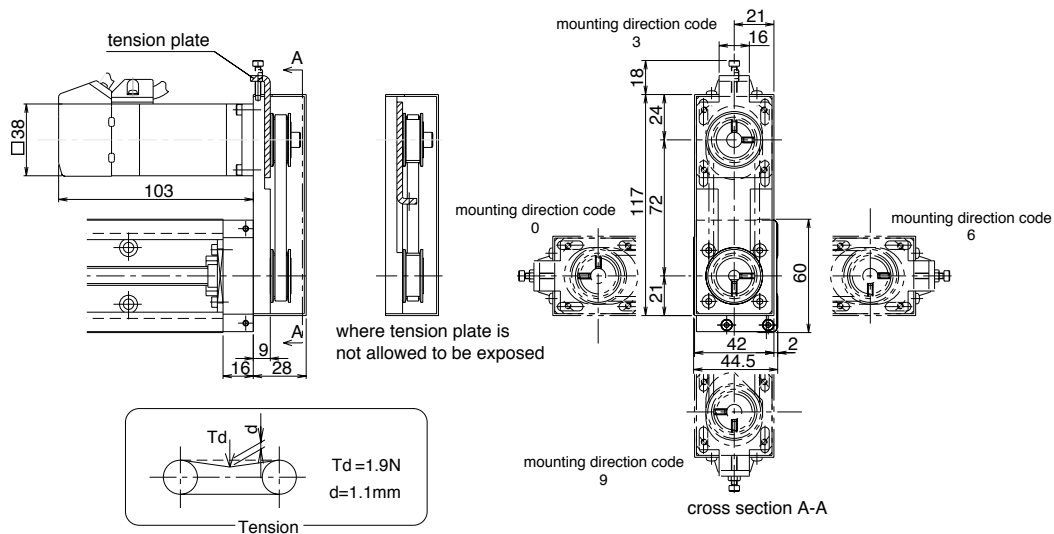

1. This drawing shows RA for MSMA01 (Panasonic).
2. Installation position of Pulley Unit can be selected at 90° intervals (mounting direction code).
3. Can be used for both with or without cover and / or sensor.
4. Tension plate can be built in and is not exposed.
5. Mass is added 0.2kg to the value of Table I-3, page I-7.
6. Inertia is added  $2.22 \times 10^{-6} kg \cdot m^2$  to the value of Table I-5, page I-8.
7. part number format

**BG33\*\*\*—\*\*\*\*/☆☆□**

Symbol of applicable motor bracket  
(see table I-14)

Mounting direction code  
(refer to cross section A-A)

Table I-14 Motor Bracket Configurations

Motor Bracket	Applicable Motors
RA	MATSUSHITA ELECTRIC INDUSTRIAL MINAS SERIES :50~100W
RB	YASUKAWA ELECTRIC SIGMA SERIES :50~100W
	MITSUBISHI ELECTRIC HC-MF SERIES :50~100W
	SANYO ELECTRIC P3 SERIES :50~100W

Please contact NB for return brackets for other stepper motors.



## <BG46 Return Pulley Unit>

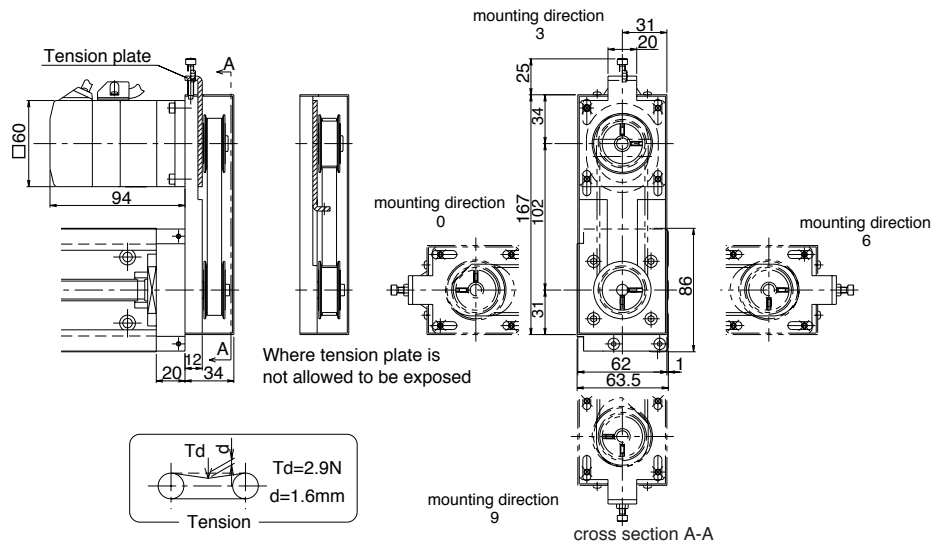

1. This drawing shows RA for MSMA01 (Panasonic).
2. Installation position of Pulley Unit can be selected at 90° intervals (mounting direction code).
3. Can be used for both with or without cover and / or sensor.
4. Tension plate can be built in and is not exposed.
5. Mass is added 0.7kg to the value of Table I-3, page I-7.
6. Inertia is added  $1.24 \times 10^{-5} \text{kg} \cdot \text{m}^2$  to the value of Table I-5, page I-8.
7. parts number format

**BG33\*\*\*—\*\*\*\*\*/**

**Symbol of applicable motor bracket**  
(see table I-15)

**Mounting direction code**  
(refer to cross section A-A)

Table I-15 Motor Bracket Configurations

Motor Bracket	Applicable Motors
RA	MATSUSHITA ELECTRIC INDUSTRIAL MINAS SERIES : 200W
RB	YASUKAWA ELECTRIC SIGMA SERIES : 200W
	mitsubishi electric HC-MF SERIES : 200W
	SANYO ELECTRIC P3 SERIES : 200W
RC	ORIENTAL MOTOR STEPPER MOTOR □60 SERIES

Please contact NB for return brackets for other stepper motors.

# SENSOR



PACIFIC INTERNATIONAL BEARING SALES, INC.  
800.228.8895 • WWW.PACIFICBEARINGSALES.COM

Photo-sensor or proximity-sensor may be attached to the BG actuator with our optional sensor-mounting rail. Tapped holes are machined on both side of guide rail, allowing attachment of sensor to either side. Standard positioning (without special instruction from customer) would be to the left of the motor mount end. Sensor option includes the items that are listed below.

## BG20

### S Specification (Compact Photo Micro Sensor)

— Without Cover —

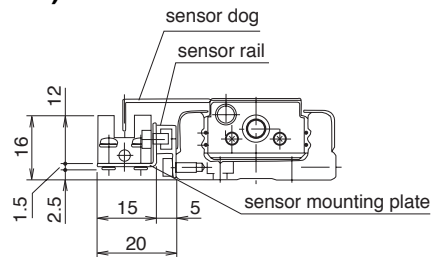
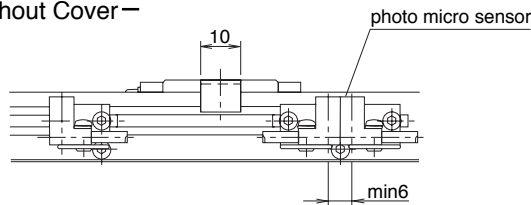

— With Cover —

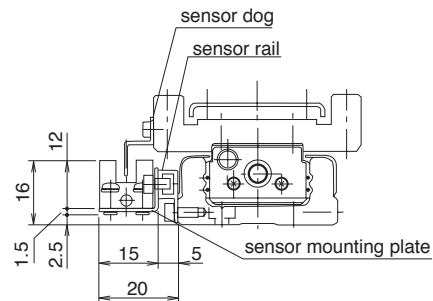
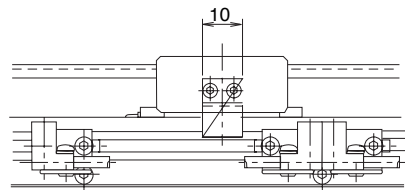

- Accessories
- |                                   |       |
|-----------------------------------|-------|
| micro photo sensor (PM-L24, SUNX) | 3 pcs |
| sensor mounting plate             | 3 pcs |
| sensor rail                       | 1 pc  |
| sensor dog                        | 1 pc  |

### K Specification (Proximity Sensor)

— Without Cover —

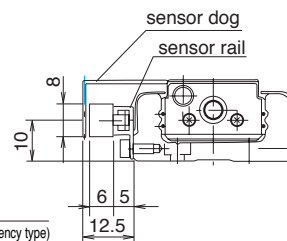
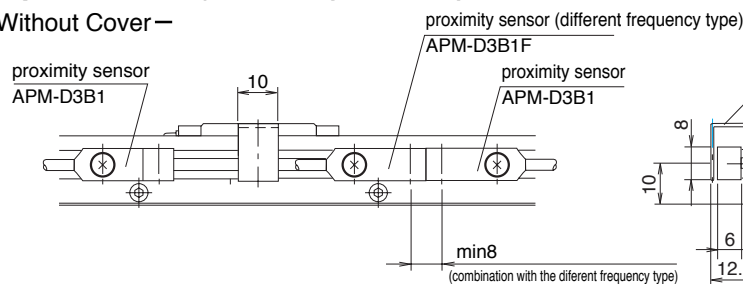

— With Cover —

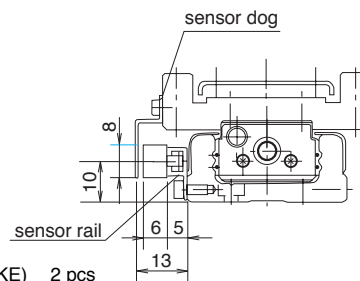
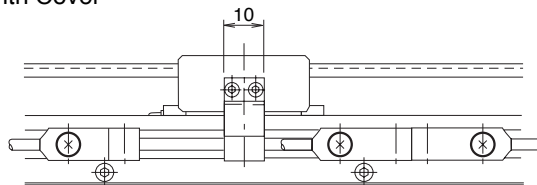

- Accessories
- |  |       |
|--|-------|
| proximity sensor (APM-D3B1, YAMATAKE)                            | 2 pcs |
| proximity sensor (different frequency type)(APM-D3B1F, YAMATAKE) | 1 pc  |
| sensor rail  | 1 pc  |
| sensor dog   | 1 pc  |



## BG26

### S Specification (Compact Photo Micro Sensor)

— Without Cover —

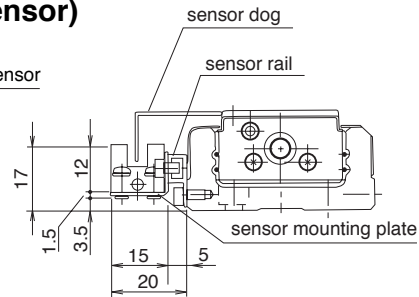
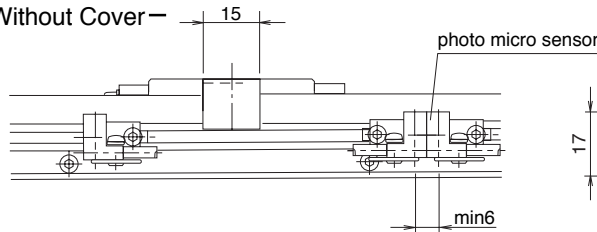

— With Cover —

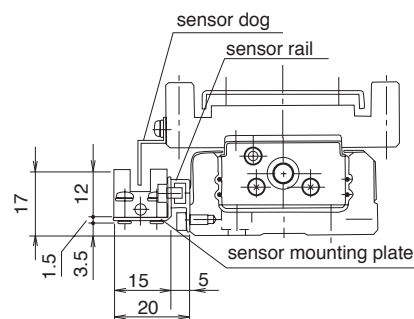
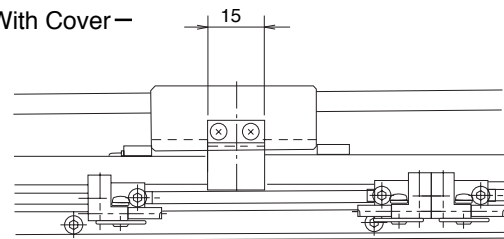

Accessories

micro photo sensor (PM-L24, SUNX)	3 pcs
sensor mounting plate	3 pcs
sensor rail	1 pc
sensor dog	1 pc

### K Specification (Proximity Sensor)

— Without Cover —

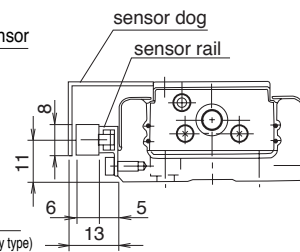
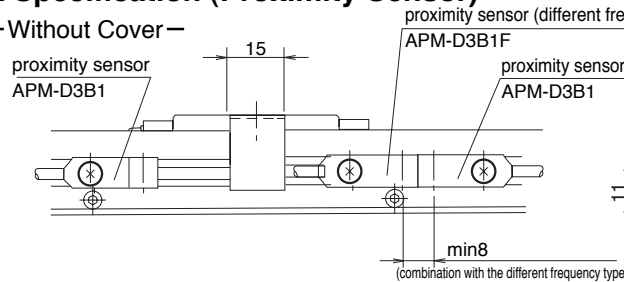

— With Cover —

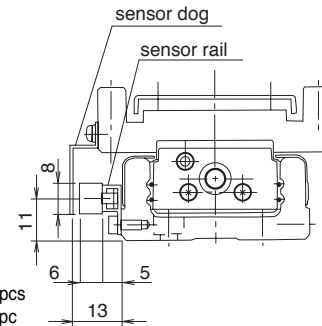
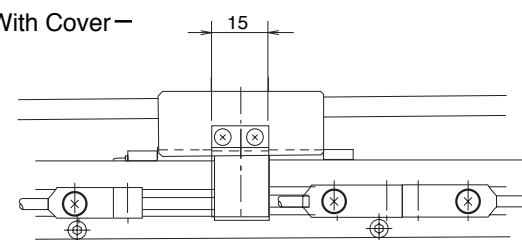

Accessories

proximity sensor (APM-D3B1, YAMATAKE)	2 pcs
proximity sensor (different frequency type)(APM-D3B1F, YAMATAKE)	1 pc
sensor rail	1 pc
sensor dog	1 pc

# BG33

## S Specification (Slim-Type Photo Micro Sensor)

— Without Cover —

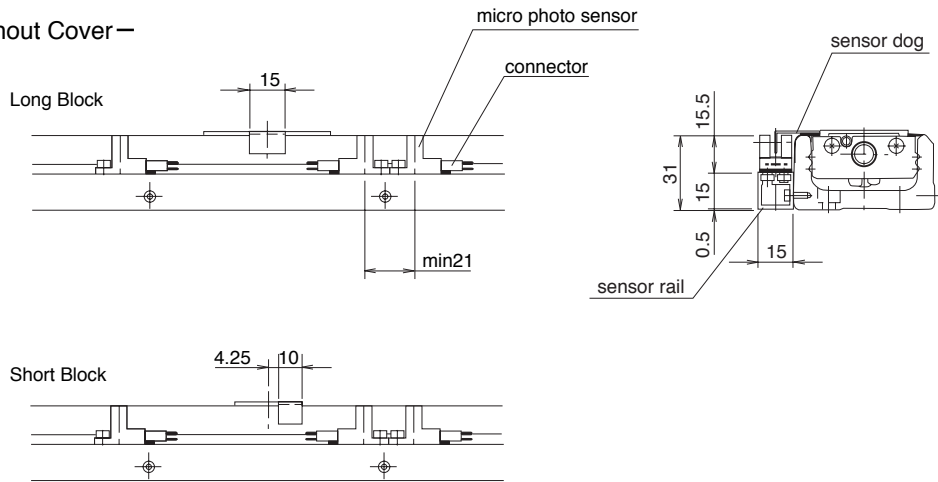

— With Cover —

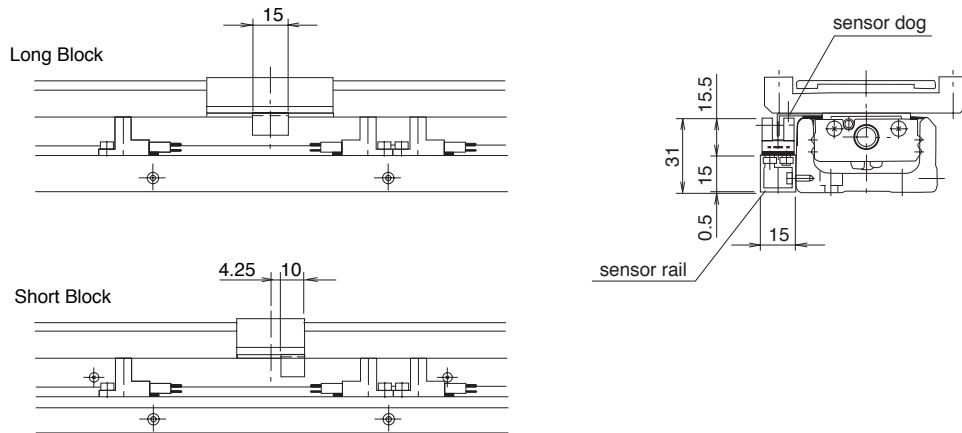

- Accessories
- |                                      |       |
|--------------------------------------|-------|
| photo micro sensor (EE-SX674, OMRON) | 3 pcs |
| connector (EE-1001, OMRON)           | 3 pcs |
| sensor rail                          | 1 pc  |
| sensor dog                           | *1 pc |
- \* 2 pcs for BG33D-150.



## BG33

### H Specification (Close Contact Capable Photo Micro Sensor)

— Without Cover —

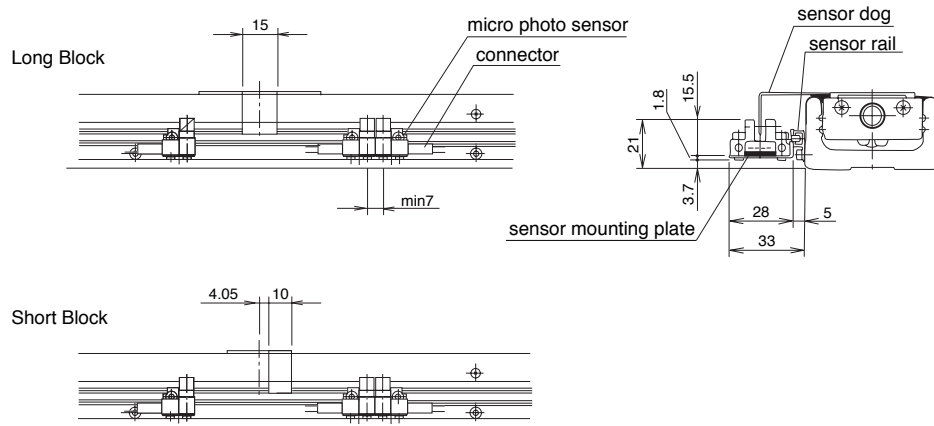

— With Cover —

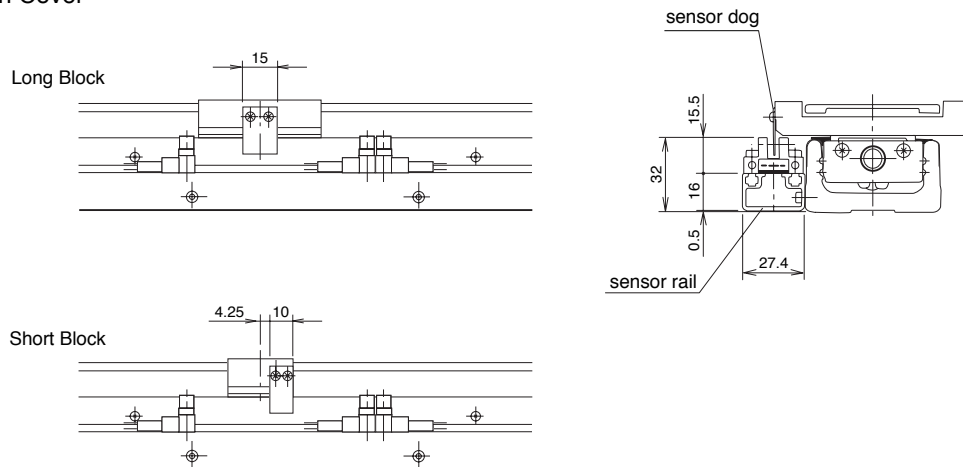

**Accessories**

photo micro sensor (EE-SX671, OMRON)	3 pcs
connector (EE-1001, OMRON)	3 pcs
sensor mounting plate (only for the without cover type)	3 pcs
sensor rail	1 pc
sensor dog	*1 pcs
* 2 pcs for BG33D-150.	

# BG33

## K Specification (Proximity Sensor)

— Without Cover —

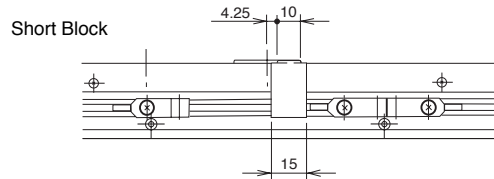
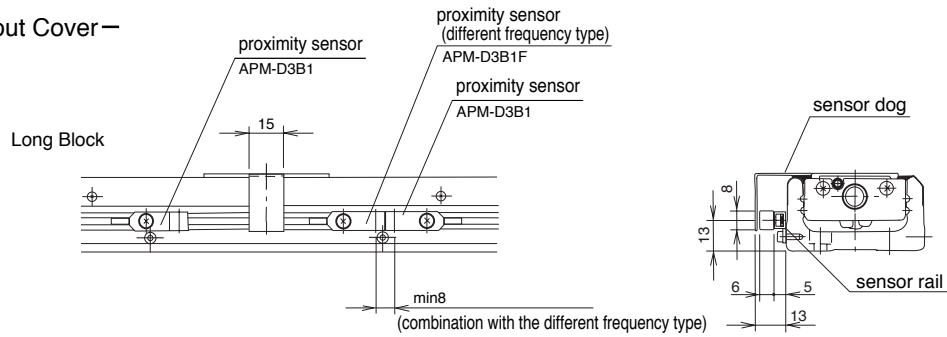

— With Cover —

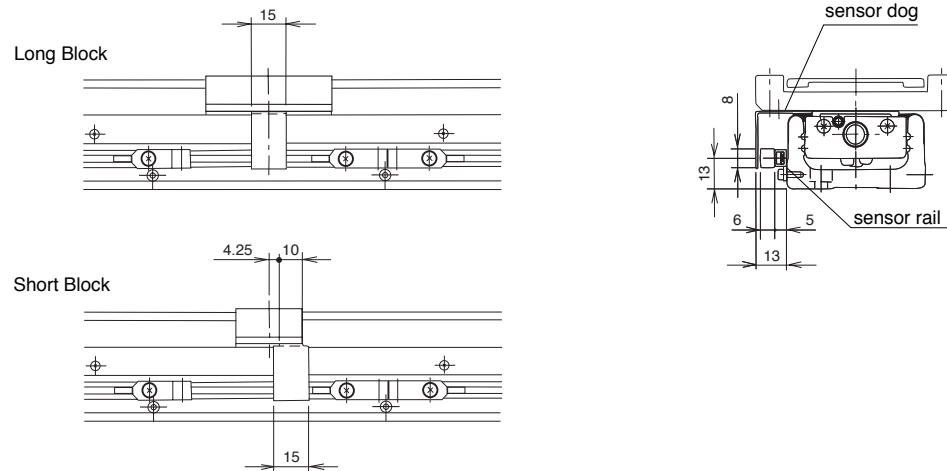

Accessories		
proximity sensor	(APM-D3B1, YAMATAKE)	2 pcs
proximity sensor (different frequency type)	(APM-D3B1F, YAMATAKE)	1 pc
sensor rail		1 pc
sensor dog		*1 pc
* 2 pcs for BG33D-150.		





## BG46

### S Specification (Slim-Type Photo Micro Sensor)

— Without Cover —

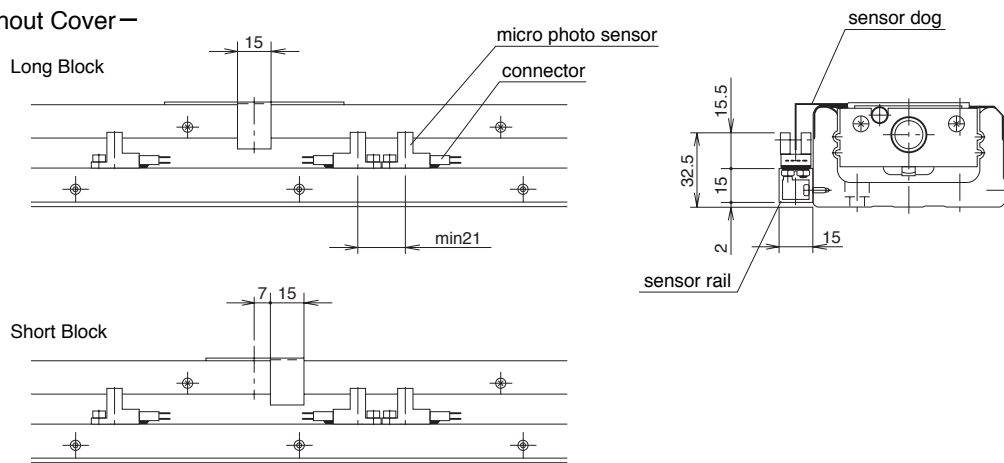

— With Cover —

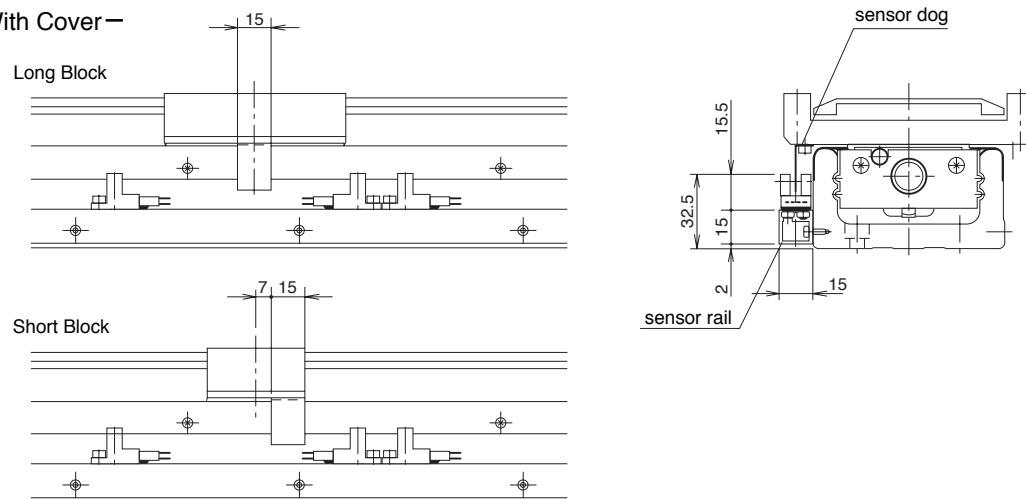

Accessories	
photo micro sensor (EE-SX674, OMRON)	3 pcs
connector (EE-1001, OMRON)	3 pcs
sensor rail	1 pc
sensor dog	1 pc



# BG46

## H Specification (Close Contact Capable Photo Micro Sensor)

—Without Cover—

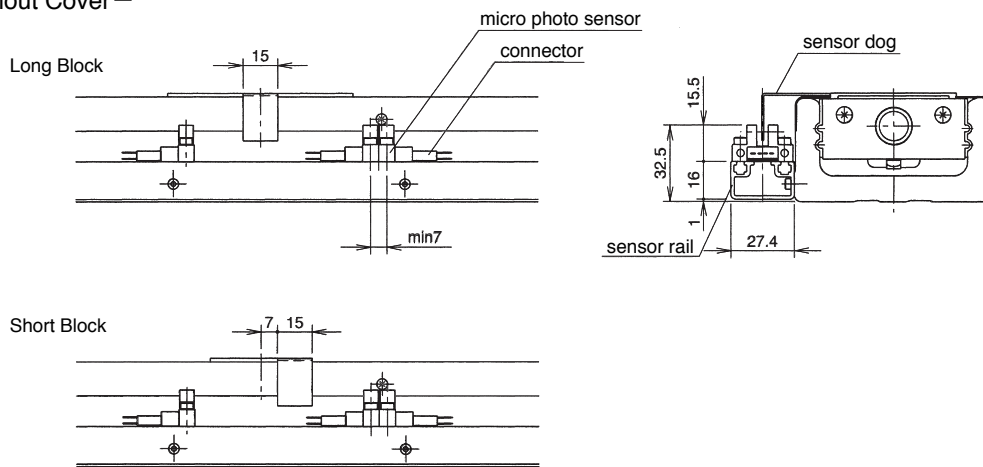

—With Cover—

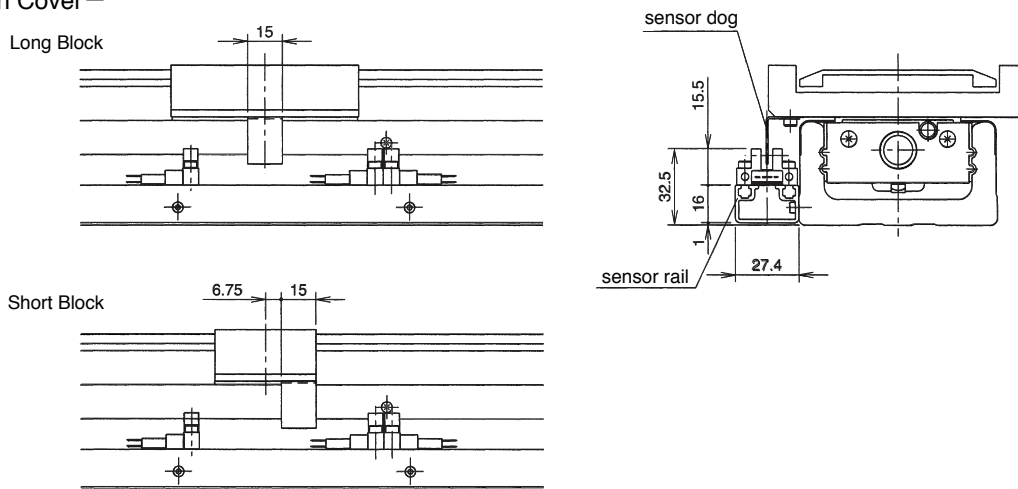

Accessories	
photo micro sensor (EE-SX671, OMRON)	3 pcs
connector (EE-1001, OMRON)	3 pcs
sensor rail	1 pc
sensor dog	1 pcs



## BG46

### K Specification (Proximity Sensor)

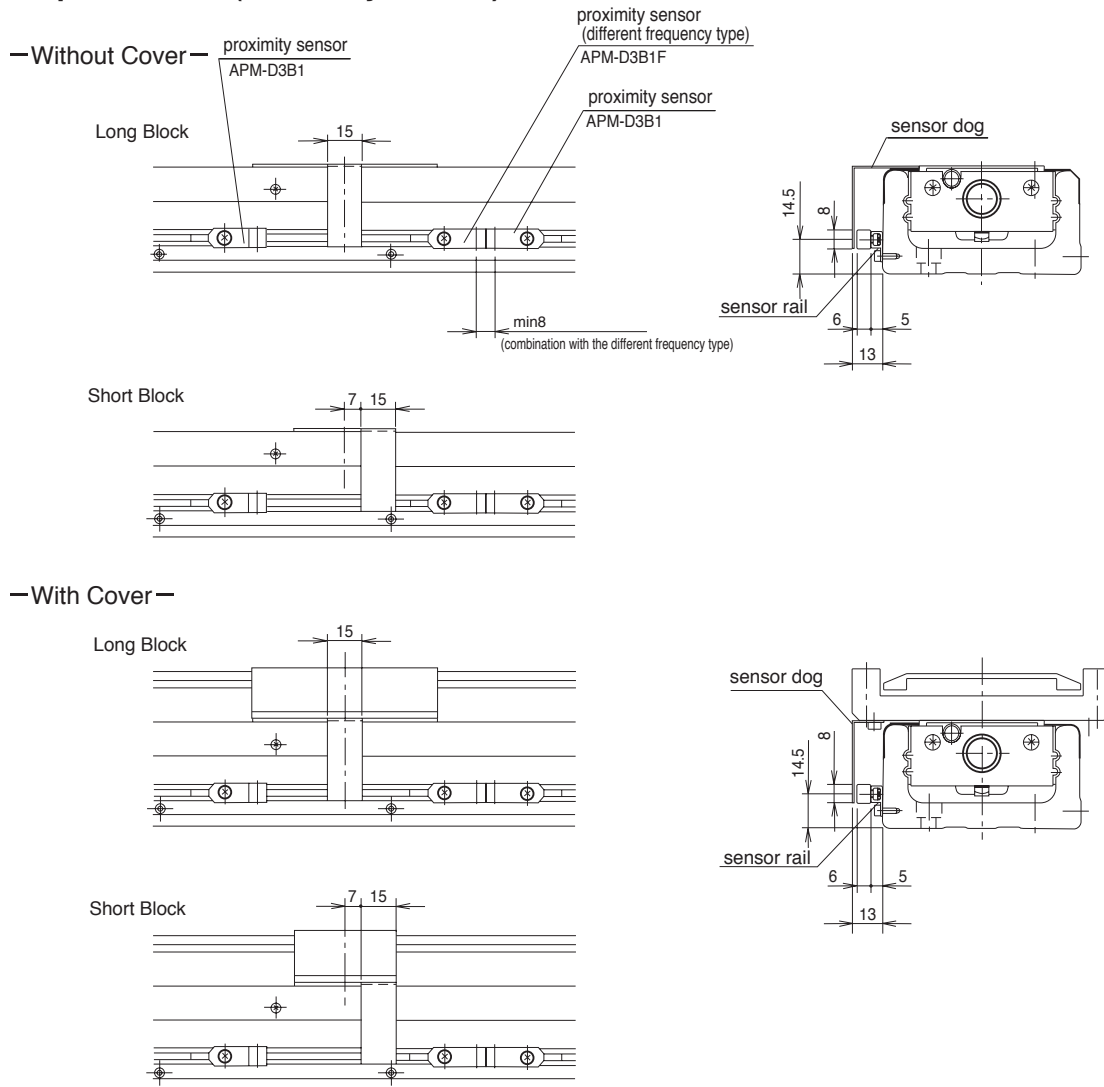

Accessories		
proximity sensor	(APM-D3B1, YAMATAKE)	2 pcs
proximity sensor (different frequency type)	(APM-D3B1F, YAMATAKE)	1 pc
sensor rail		1 pc
sensor dog		1 pc



# BG55

## S Specification (Compact Photo Micro Sensor)

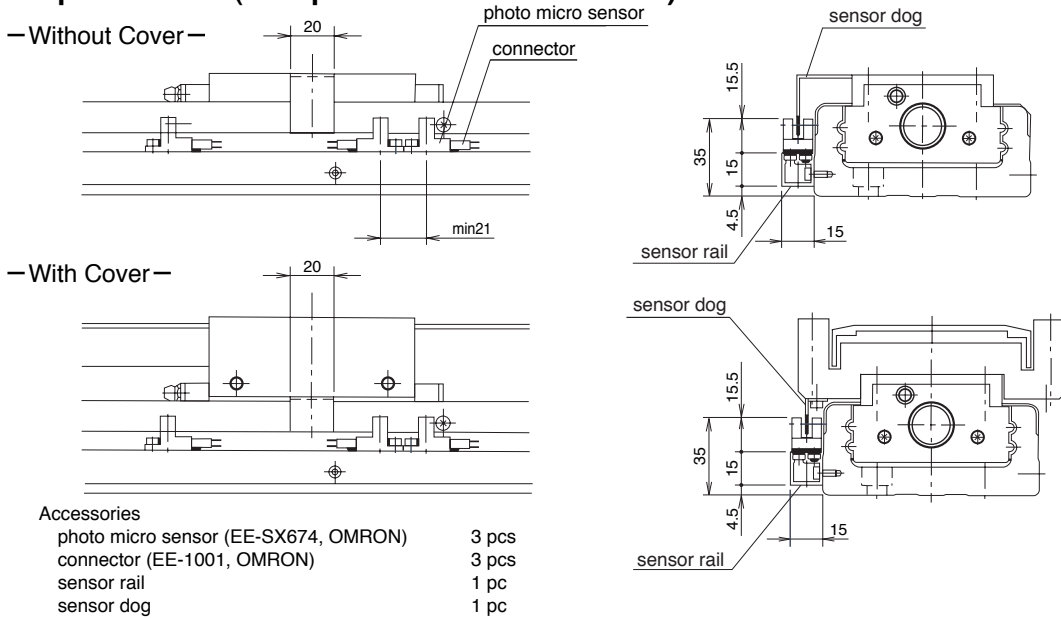

## H Specification (Close Contact Capable Photo Micro Sensor)

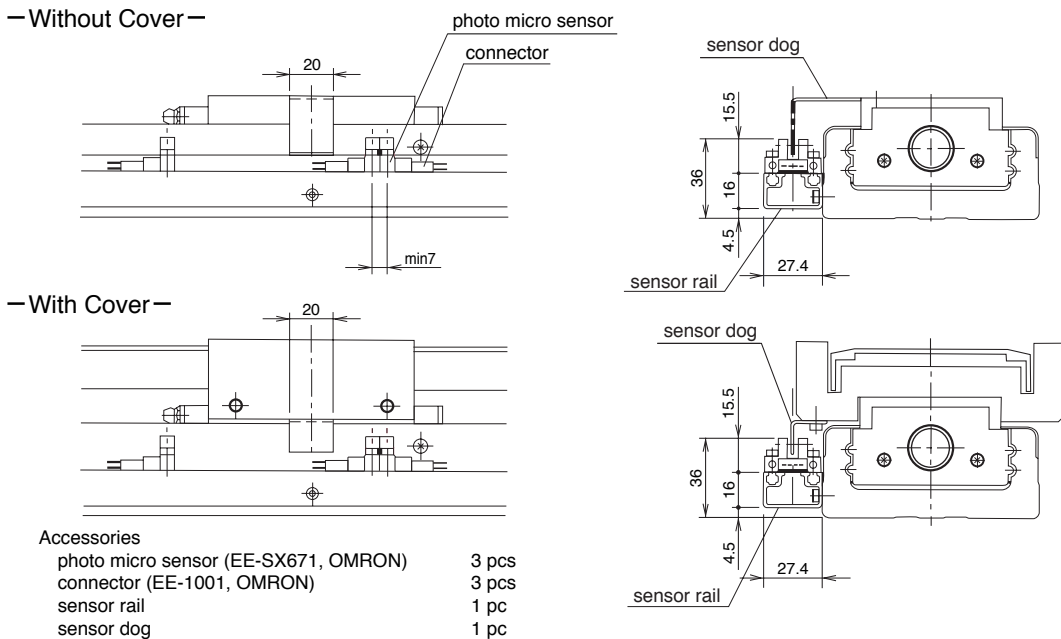



## BG55

### K Specification (Proximity Sensor)

— Without Cover —

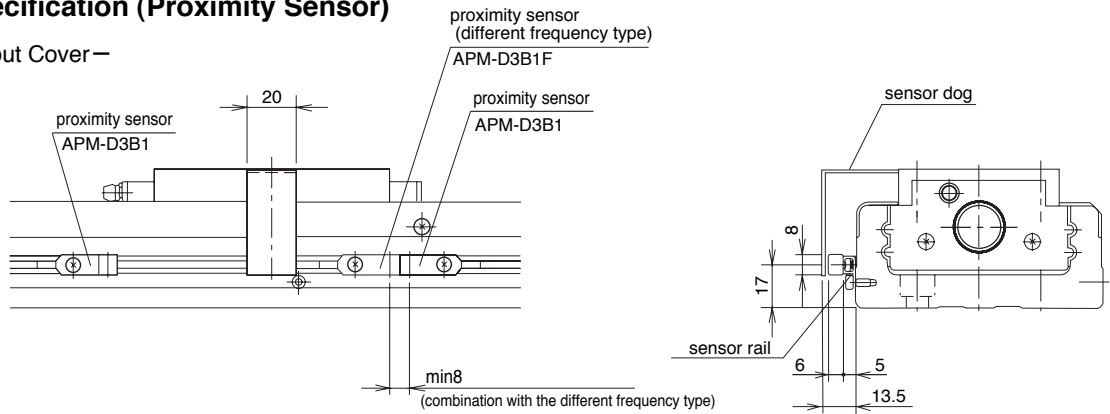

— With Cover —

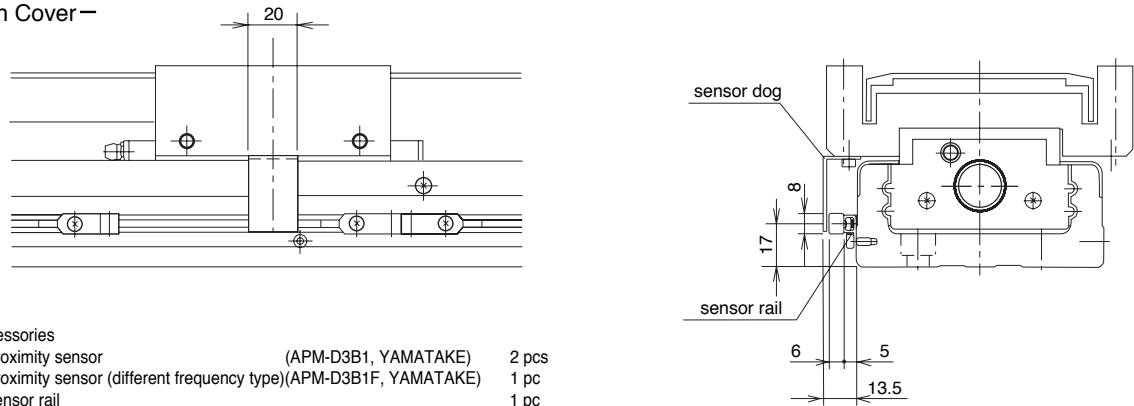

Accessories		
proximity sensor	(APM-D3B1, YAMATAKE)	2 pcs
proximity sensor (different frequency type)	(APM-D3B1F, YAMATAKE)	1 pc
sensor rail		1 pc
sensor dog		1 pc

### <PNP Sensor>

The BG type sensors can be changed to the PNP type by adding a sensor option code “PNP” at the end of the part number (excluding the BG20 and BG26 compact photo micro sensors).

Refer to Table I-16 for the model number of PNP type sensors.

Table I-16 Sensor Model Type

sensor code	sensor type	applicable model type	standard specification model type	PNP specification model type
S	slim-type photo micro sensor	BG33,BG46,BG55	EE-SX674	EE-SX674P
	compact photo micro sensor	BG20,BG26	PM-L24	not available
H	close contact capable photo micro sensor	BG33,BG46,BG55	EE-SX671	EE-SX671P
K	proximity sensor	all model types	APM-D3B1	APM-D3E1
	proximity sensor (different frequency type)	all model types	APM-D3B1F	APM-D3E1F

# POSITIONING PIN HOLE



For the BG type, positioning pin holes can be provided on the slide block or the sub-table by adding the option code "PS" or "PW" at the end of the part number. When two blocks are used in the BG, the both blocks will be processed.

It is useful when exacting reassembly positioning is required.

When the code "PS" is added, the drilling is processed only on the mounting surface. On the other hand, when the code "PW" is specified for a BG with a cover, straight pins will be used at the connecting area of the slide block and the sub table (although the position is the same as the for "PS").

Note that only hole drilling is processed to the mounting surface and that no straight pin will be attached.

## BG20A,B

For the two-block type, the both blocks will be processed.

— Without Cover —

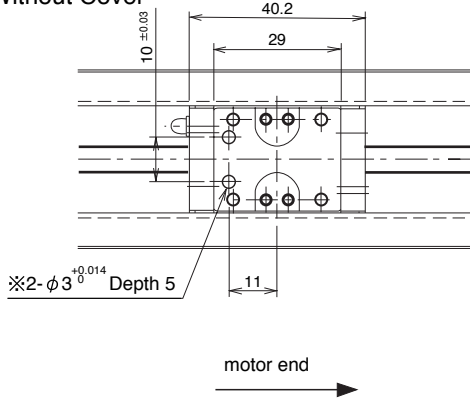

— With Cover —

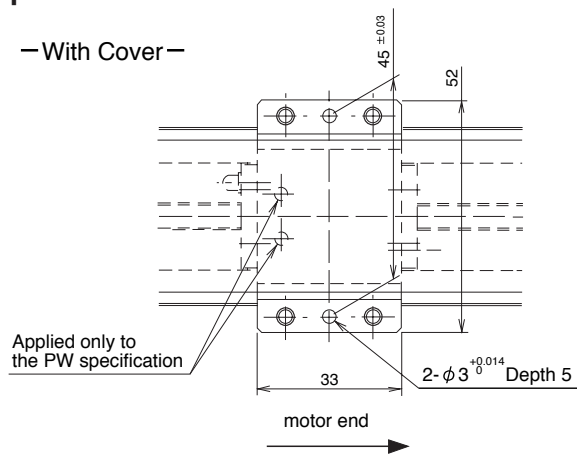

※For some cases, a shallow counter-bore of  $\phi 4$  will be machined at the entrance of the area with "※" to remove a hardened layer.

## BG26A,B

For the two-block type, the both blocks will be processed.

— Without Cover —

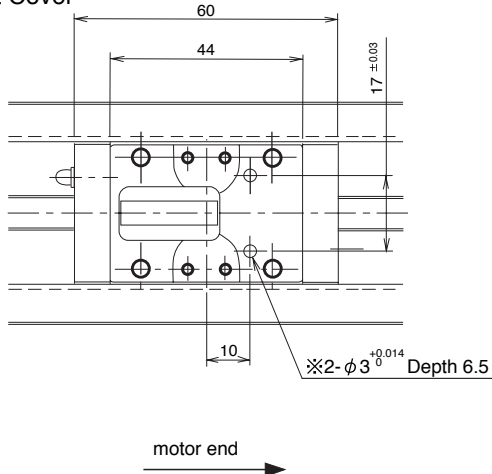

— With Cover —

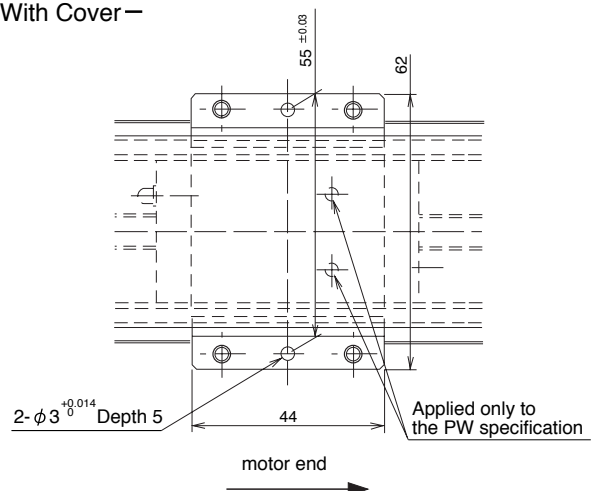

※For some cases, a shallow counter-bore of  $\phi 4$  will be machined at the entrance of the area with "※" to remove a hardened layer.



## BG33A,B

For the two-block type, the both blocks will be processed.

— Without Cover —

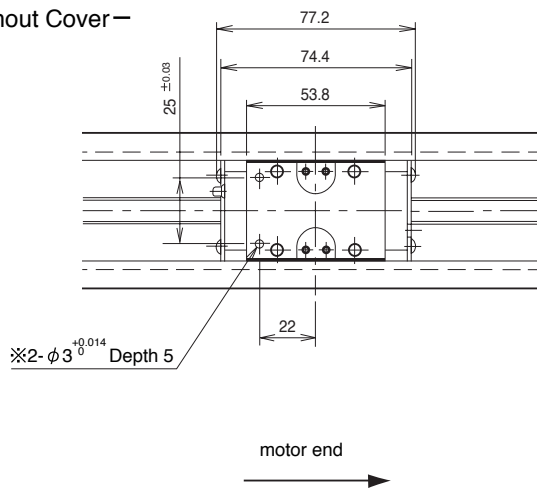

— With Cover —

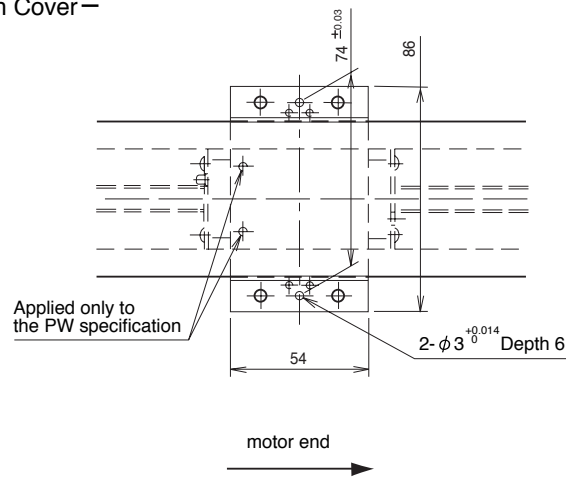

※For some cases, a shallow counter-bore of  $\phi 4$  will be machined at the entrance of the area with "※" to remove a hardened layer.

## BG33C,D

For the two-block type, the both blocks will be processed.

— Without Cover —

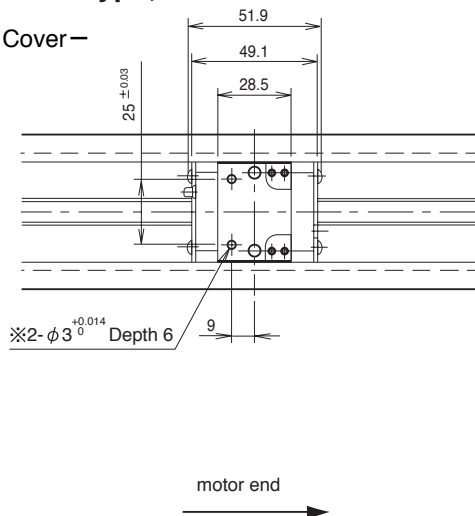

— With Cover —

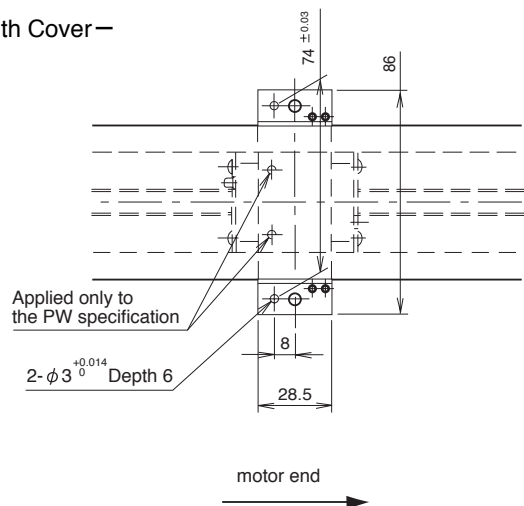

※For some cases, a shallow counter-bore of  $\phi 4$  will be machined at the entrance of the area with "※" to remove a hardened layer.



## BG46A,B

For the two-block type, the both blocks will be processed.

— Without Cover —

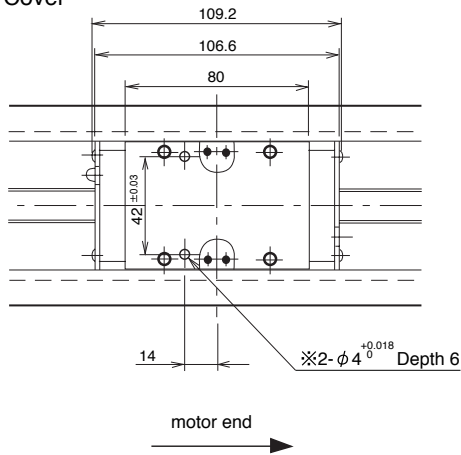

— With Cover —

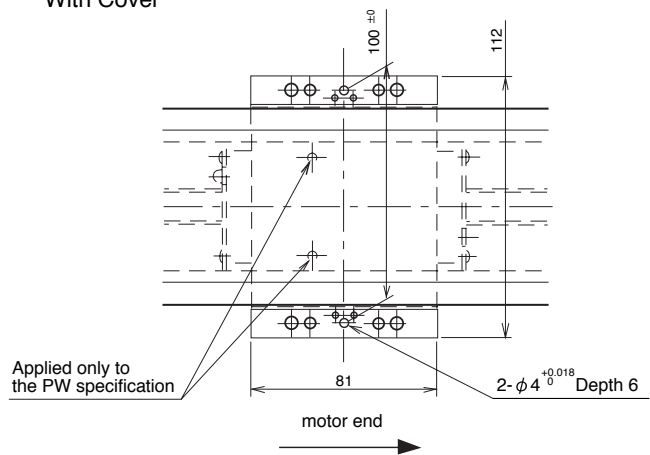

※For some cases, a shallow counter-bore of  $\phi 5$  will be machined at the entrance of the area with "※" to remove a hardened layer.

## BG46C,D

For the two-block type, the both blocks will be processed.

— Without Cover —

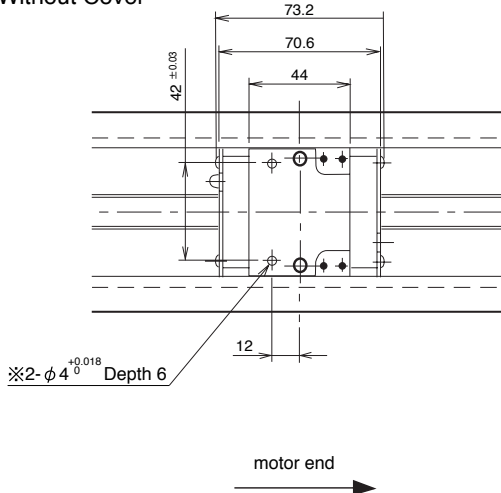

— With Cover —

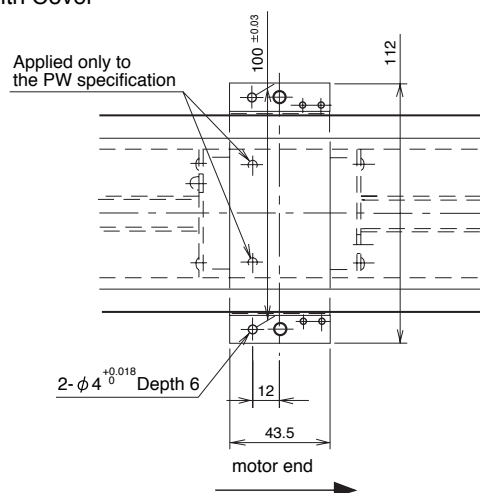

※For some cases, a shallow counter-bore of  $\phi 5$  will be machined at the entrance of the area with "※" to remove a hardened layer.





## BG55A,B

For the two-block type, the both blocks will be processed.

—Without Cover—

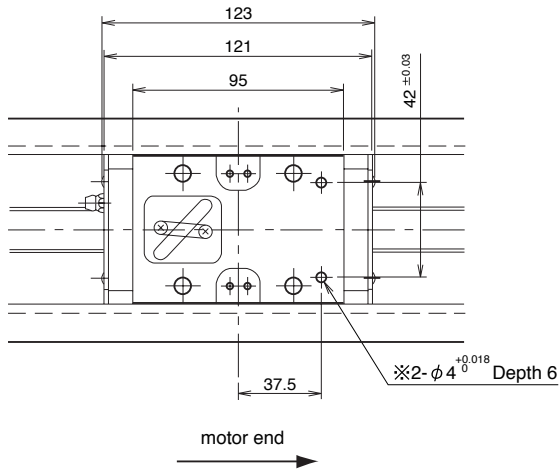

—With Cover—

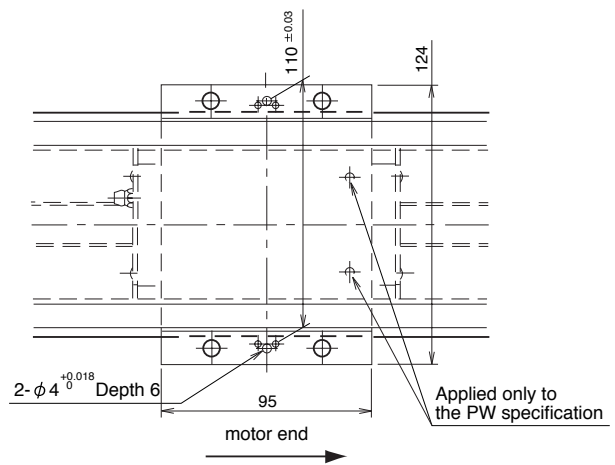

※For some cases, a shallow counter-bore of φ5 will be machined at the entrance of the area with "※" to remove a hardened layer.



# BG20A,B –Without Top-Cover–

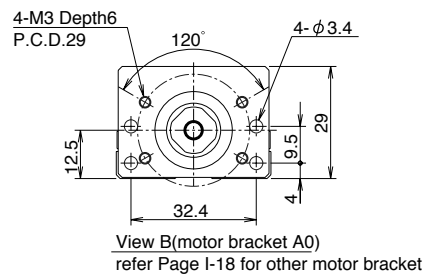
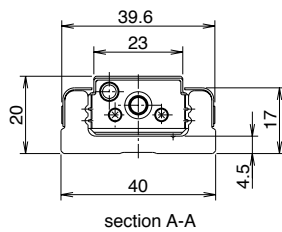
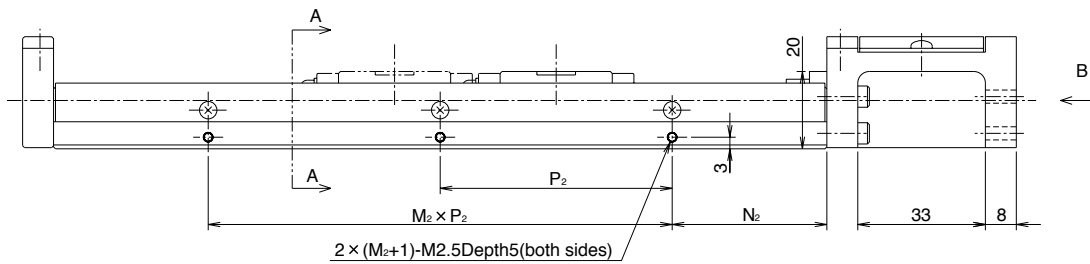
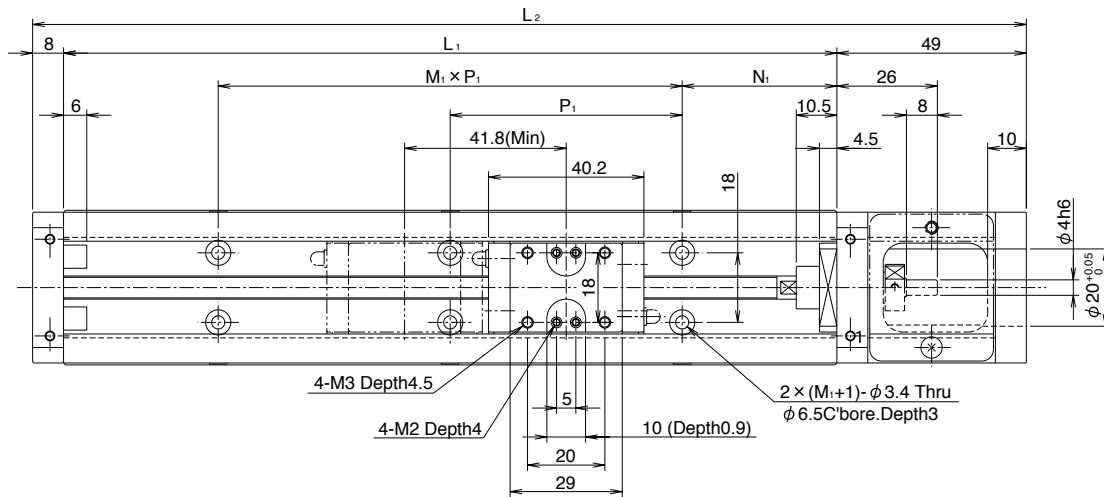



## -With Top-Cover-

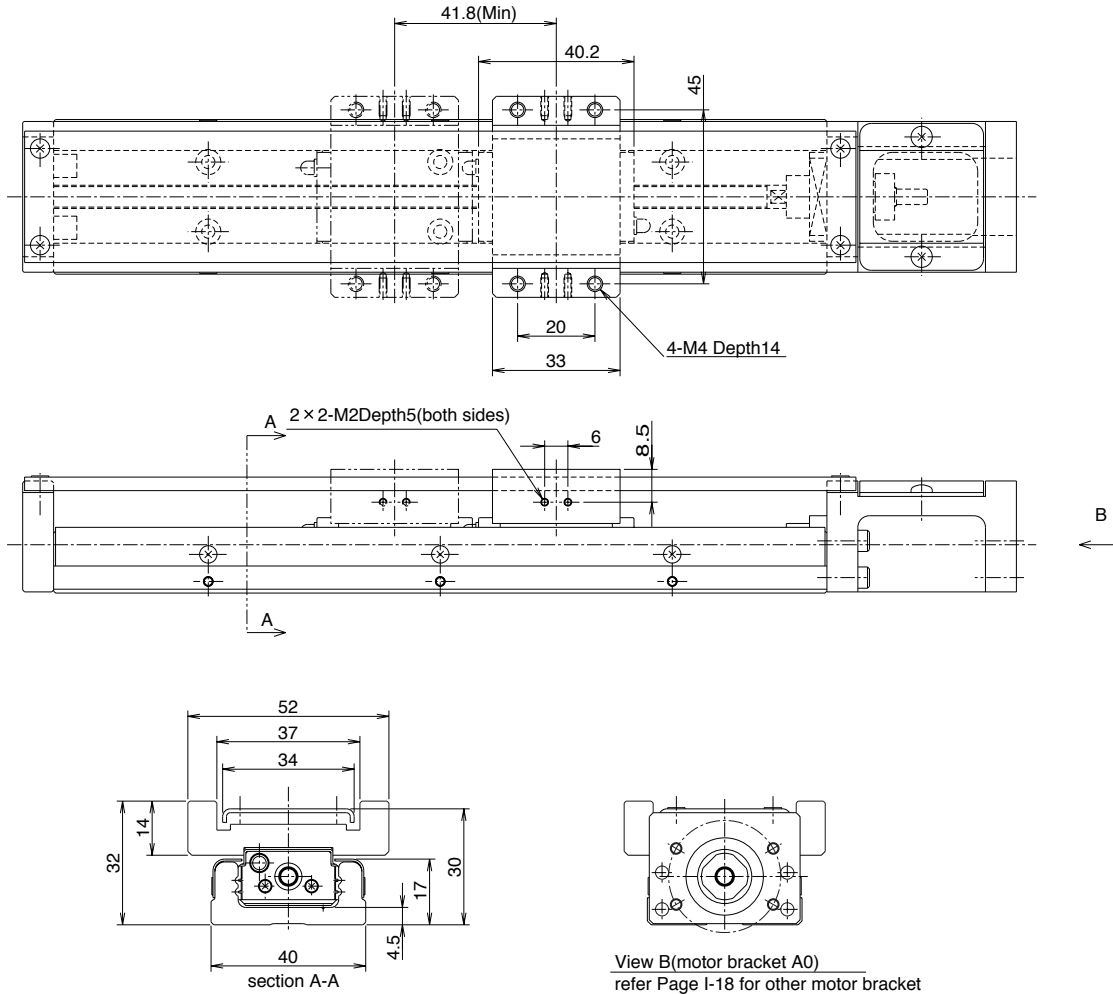

View B (motor bracket A0)  
refer Page I-18 for other motor bracket

dimensions						stroke limit	
$L_1$	$L_2$	$N_1$	$M_1 \times P_1$	$N_2$	$M_2 \times P_2$	BG20A	BG20B
100	157	20	1 × 60	20	1 × 60	43	—
150	207	15	2 × 60	15	2 × 60	93	51
200	257	40		40		143	101

Stroke limit is traveling distance between both ends of the dampers.

# BG26A,B –Without Top-Cover–

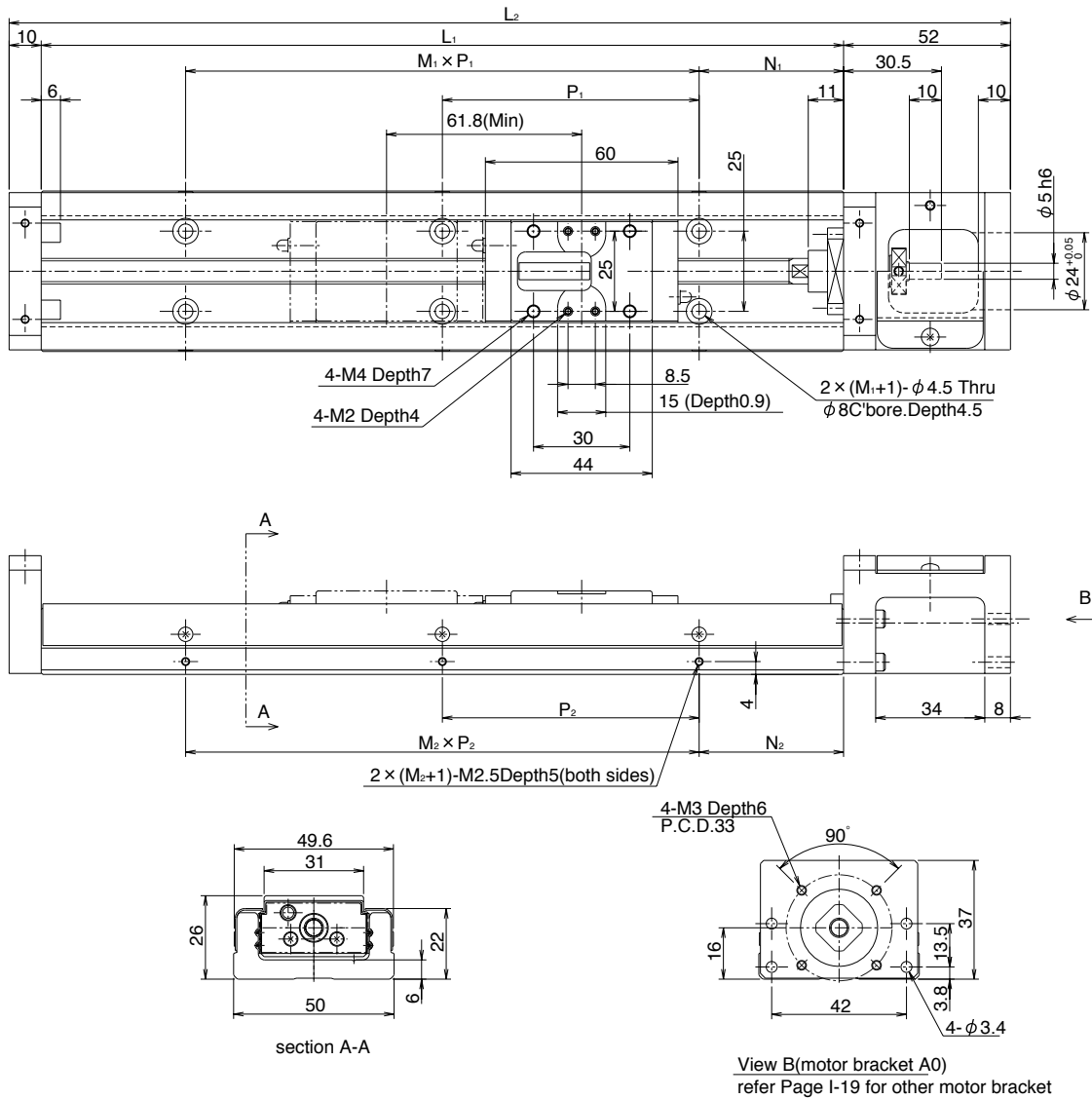



## -With Top-Cover-

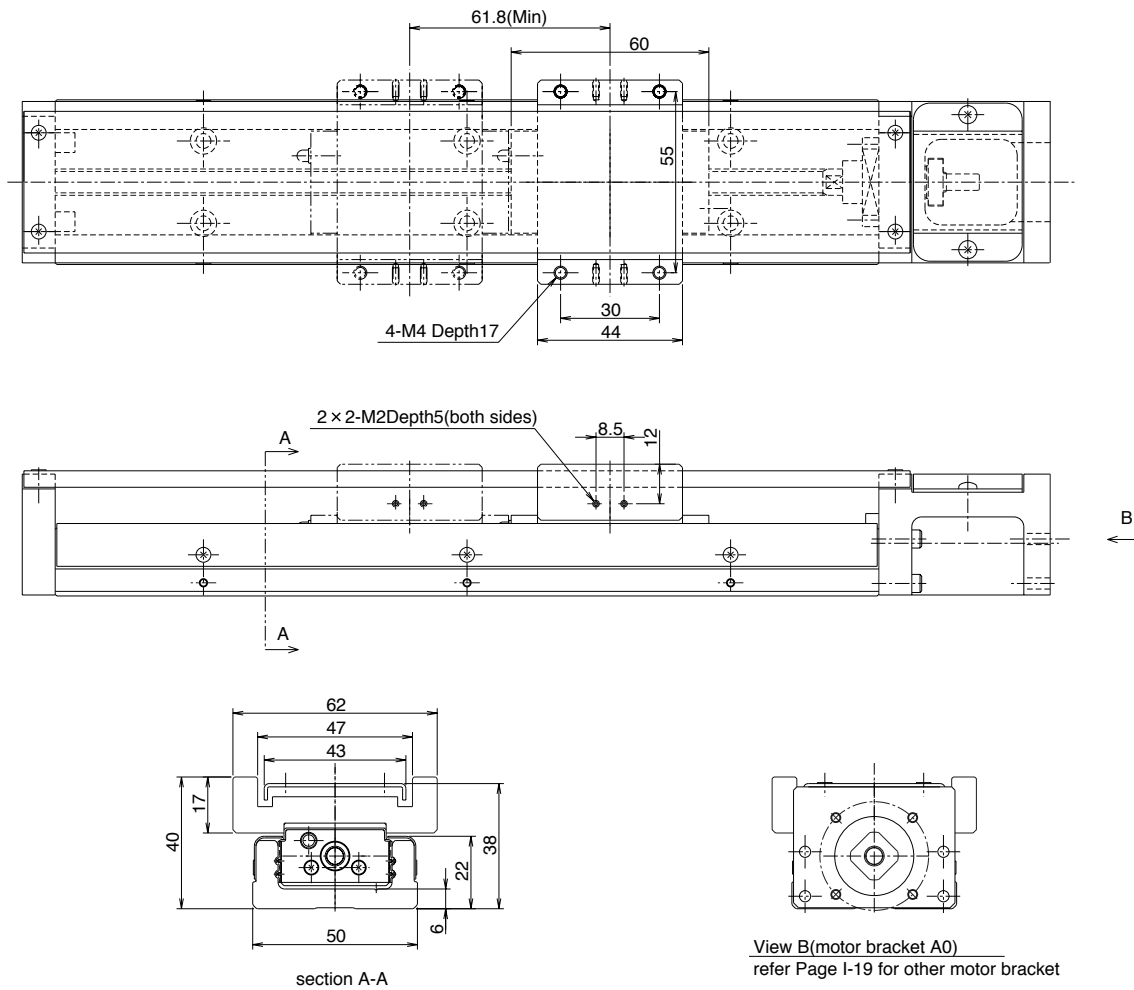

dimensions						stroke limit	
L <sub>1</sub>	L <sub>2</sub>	N <sub>1</sub>	M <sub>1</sub> × P <sub>1</sub>	N <sub>2</sub>	M <sub>2</sub> × P <sub>2</sub>	BG26A	BG26B
150	212	35	1 × 80	35	1 × 80	73	—
200	262	20	2 × 80	20	2 × 80	123	61
250	312	45		45		173	111
300	362	30	3 × 80	30	3 × 80	223	161

Stroke limit is traveling distance between both ends of the dampers.



# BG33A,B –Without Top-Cover–

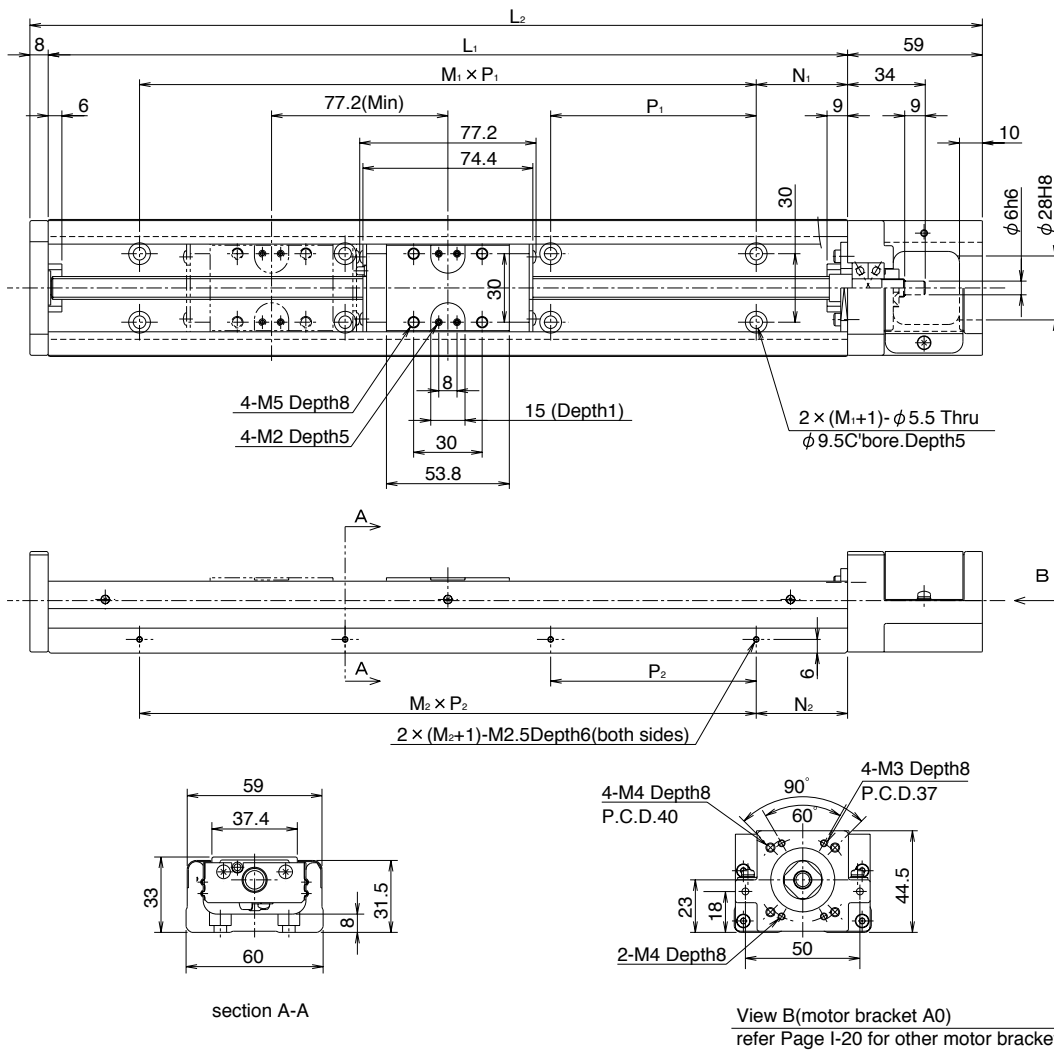



## -With Top-Cover-

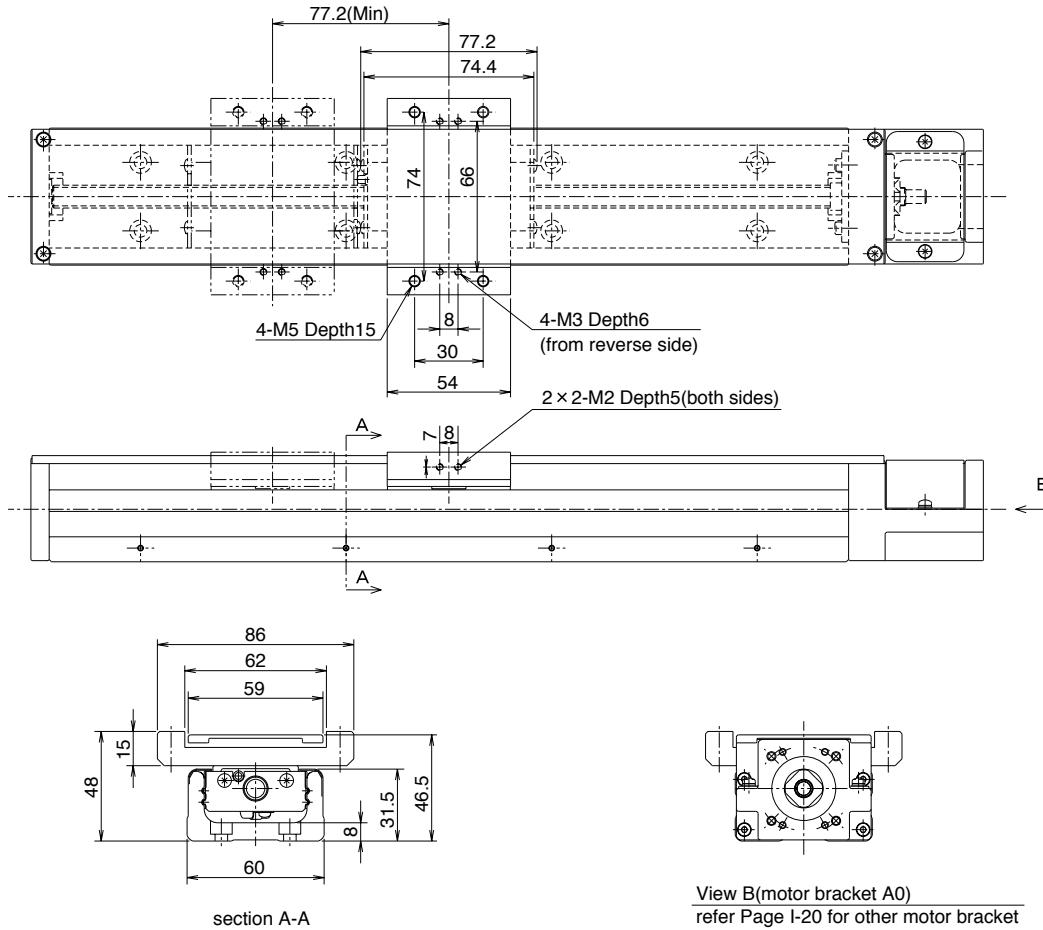

dimensions						stroke limit				
L <sub>1</sub>	L <sub>2</sub>	N <sub>1</sub>	M <sub>1</sub> × P <sub>1</sub>	N <sub>2</sub>	M <sub>2</sub> × P <sub>2</sub>	BG33A	BG33B			
150	217	25	1 × 100	25	1 × 100	60	—			
200	267					110	—			
300	367					210	133			
400	467					310	233			
500	567					410	333			
600	667	50	3 × 100	50	4 × 100	410	333			
						510	433			
						5 × 100	510	433		

Stroke limit is traveling distance between both ends of the dampers.

# BG33C,D –Without Top-Cover–

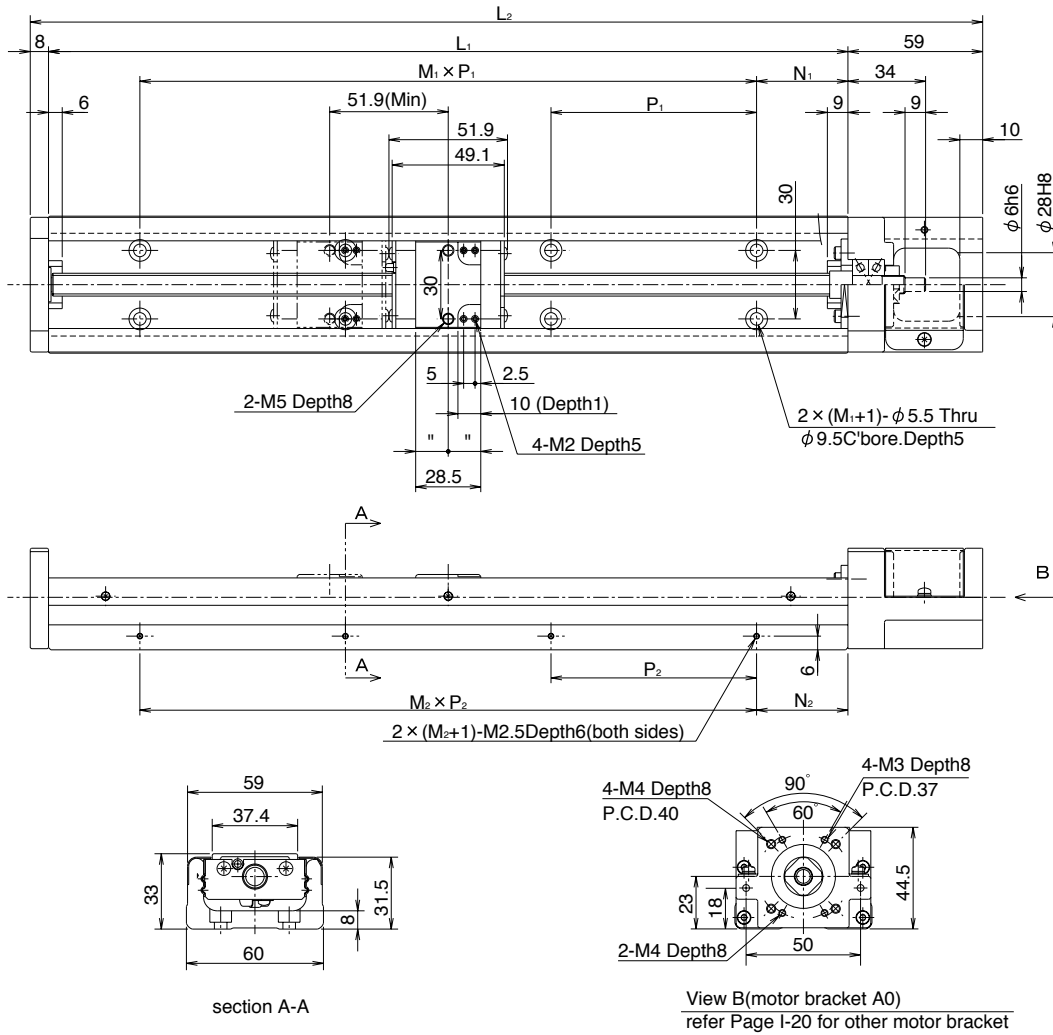





## -With Top-Cover-

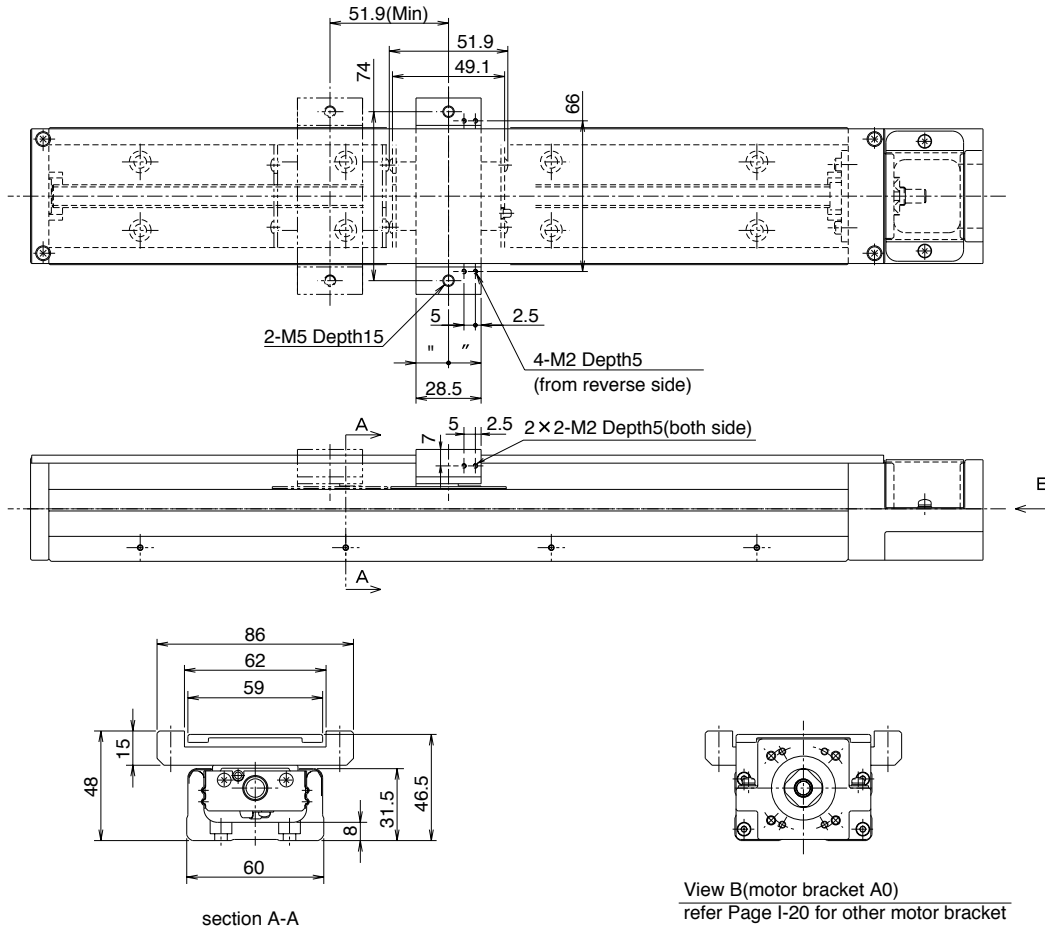

dimensions						stroke limit	
L <sub>1</sub>	L <sub>2</sub>	N <sub>1</sub>	M <sub>1</sub> × P <sub>1</sub>	N <sub>2</sub>	M <sub>2</sub> × P <sub>2</sub>	BG33C	BG33D
150	217	25		25		85	34
200	267	50	1 × 100	50	1 × 100	135	84
300	367		2 × 100		2 × 100	235	184
400	467		3 × 100		3 × 100	335	284
500	567		4 × 100		4 × 100	435	384
600	667		5 × 100		5 × 100	535	484

Stroke limit is traveling distance between both ends of the dampers.



# BG46A,B –Without Top-Cover–

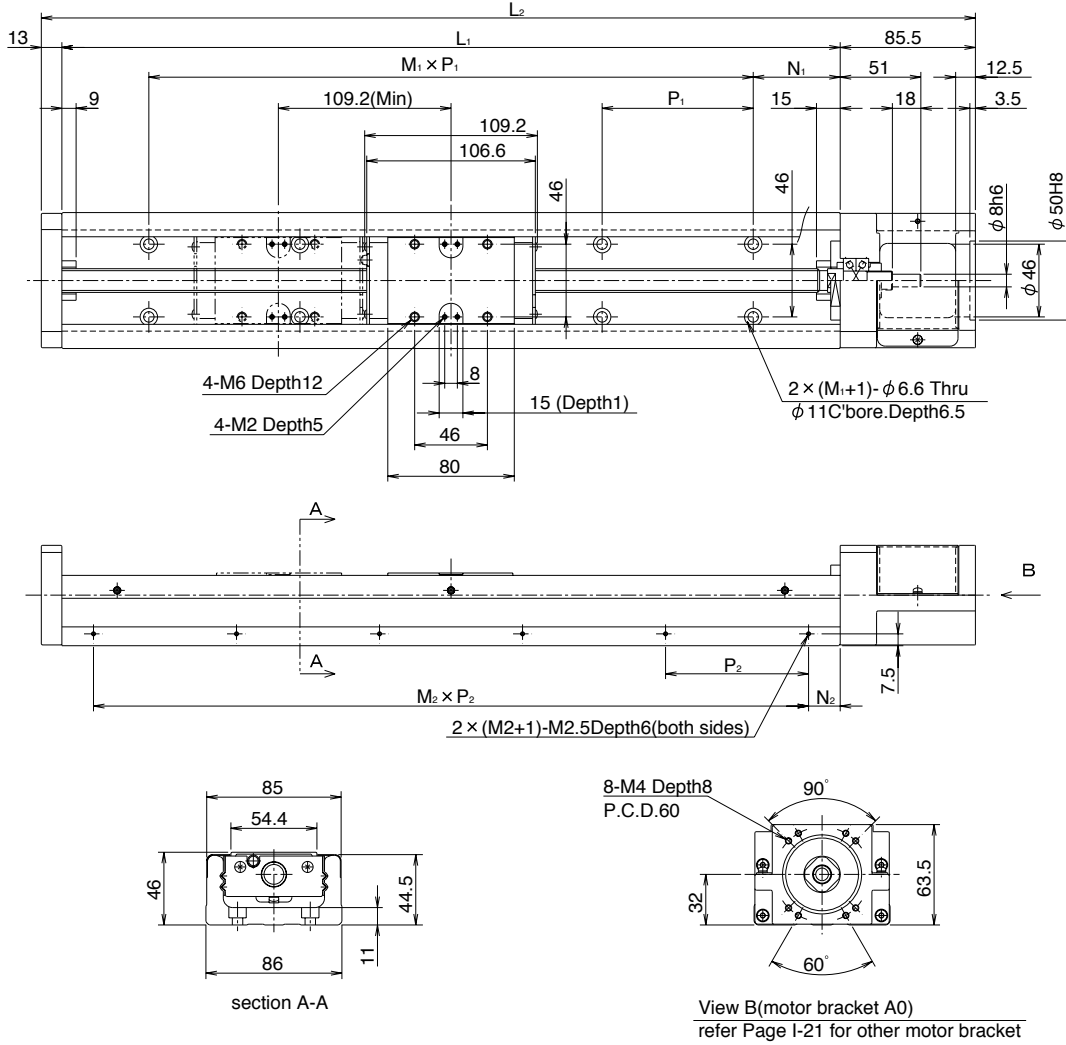



## -With Top-Cover-

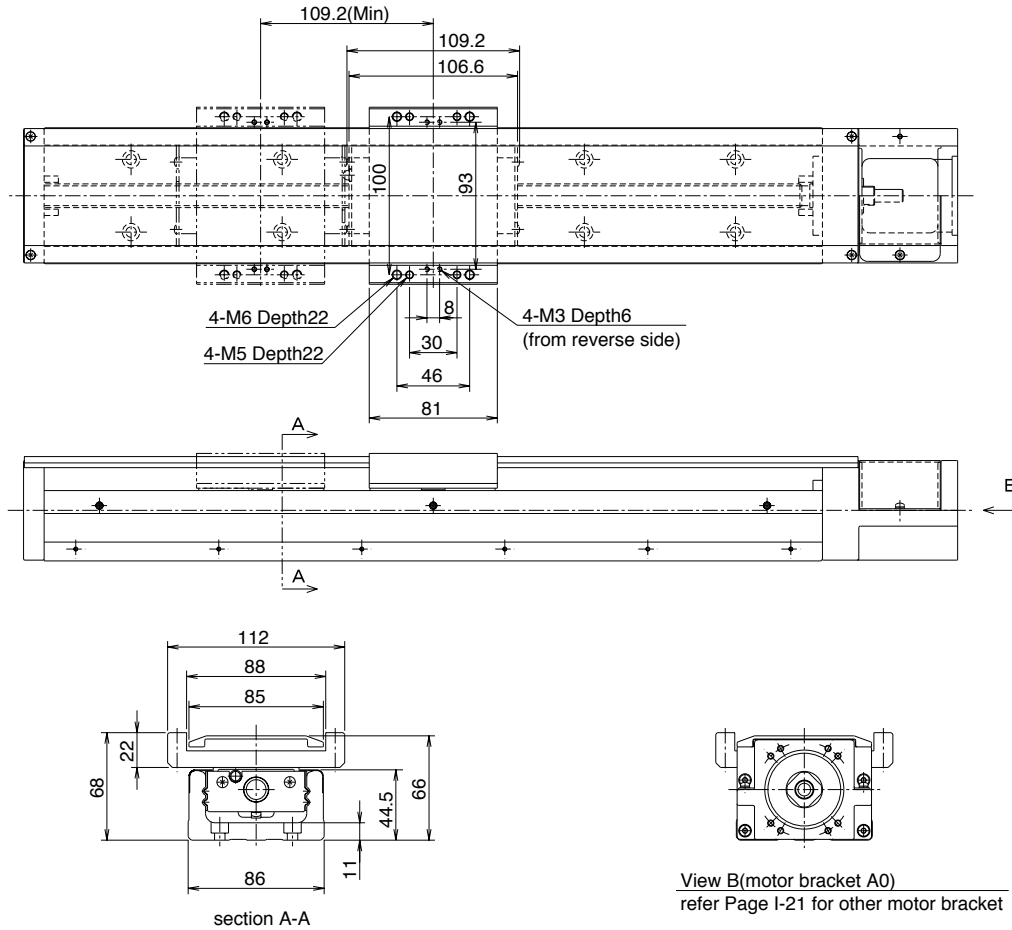

dimensions						stroke limit	
L <sub>1</sub>	L <sub>2</sub>	N <sub>1</sub>	M <sub>1</sub> × P <sub>1</sub>	N <sub>2</sub>	M <sub>2</sub> × P <sub>2</sub>	BG46A	BG46B
340	438.5	70	2 × 100	20	3 × 100	209	100
440	538.5		3 × 100		4 × 100	309	200
540	638.5		4 × 100		5 × 100	409	300
640	738.5		5 × 100		6 × 100	509	400
740	838.5		6 × 100		7 × 100	609	500
840	938.5		7 × 100		8 × 100	709	600
940	1,038.5		8 × 100		9 × 100	809	700
1,040	1,138.5		9 × 100		10 × 100	909	800
1,140	1,238.5		10 × 100		11 × 100	1,009	900
1,240	1,338.5		11 × 100		12 × 100	1,109	1,000

Stroke limit is traveling distance between both ends of the dampers.

# BG46C,D –Without Top-Cover–

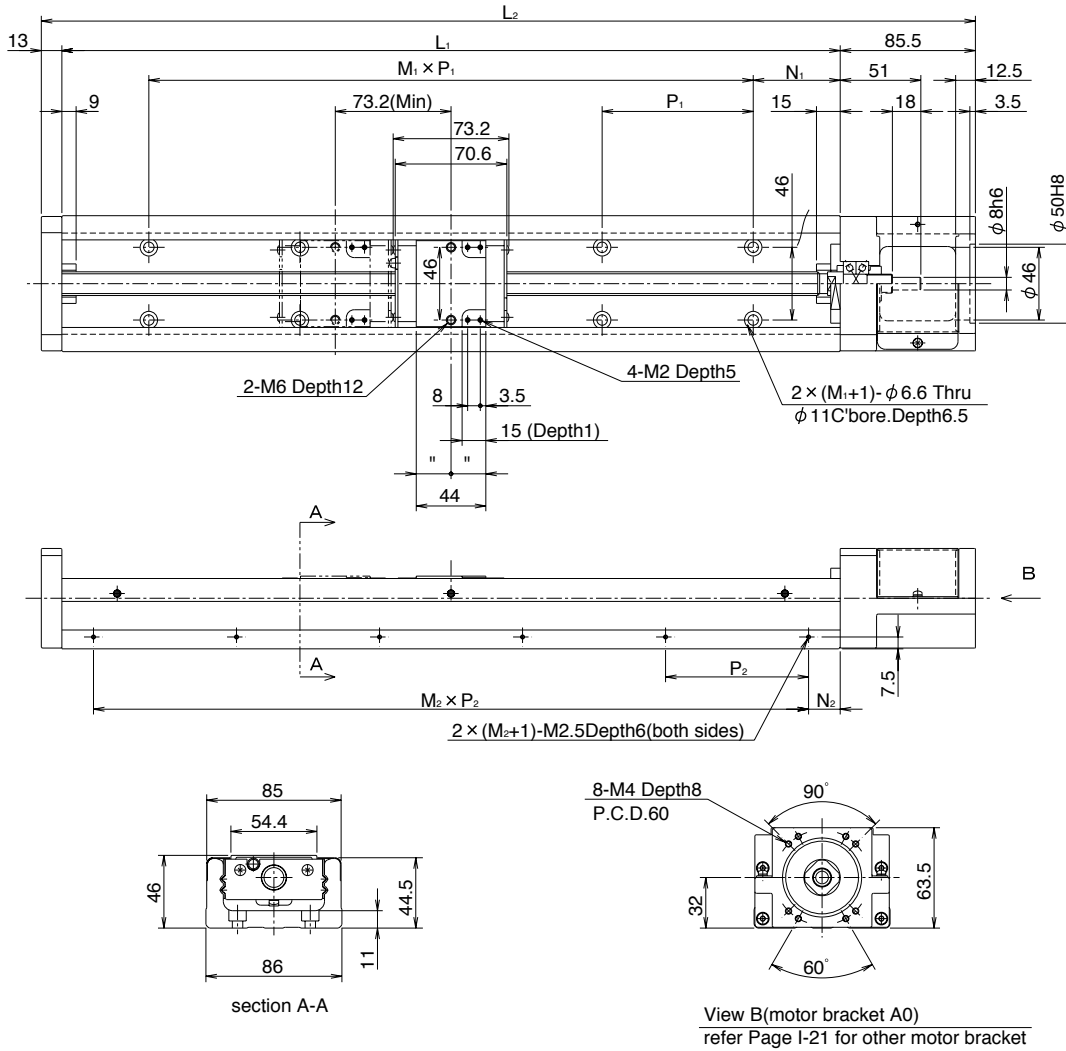



## -With Top-Cover-

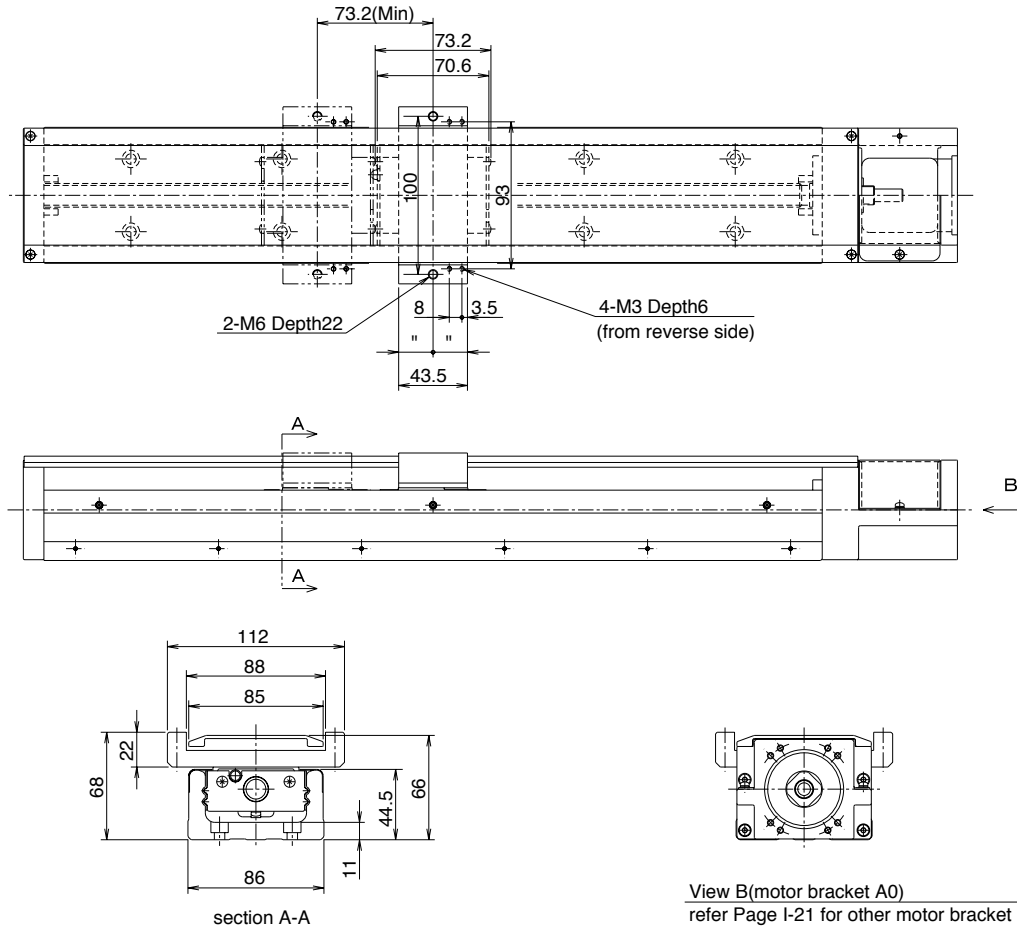

dimensions						stroke limit	
L <sub>1</sub>	L <sub>2</sub>	N <sub>1</sub>	M <sub>1</sub> × P <sub>1</sub>	N <sub>2</sub>	M <sub>2</sub> × P <sub>2</sub>	BG46C	BG46D
340	438.5	70	2 × 100	20	3 × 100	245	172
440	538.5		3 × 100		4 × 100	345	272
540	638.5		4 × 100		5 × 100	445	372
640	738.5		5 × 100		6 × 100	545	472
740	838.5		6 × 100		7 × 100	645	572
840	938.5		7 × 100		8 × 100	745	672
940	1,038.5		8 × 100		9 × 100	845	772
1,040	1,138.5		9 × 100		10 × 100	945	872
1,140	1,238.5		10 × 100		11 × 100	1,045	972
1,240	1,338.5		11 × 100		12 × 100	1,145	1,072

Stroke limit is traveling distance between both ends of the dampers.

# BG55A,B –Without Top-Cover–

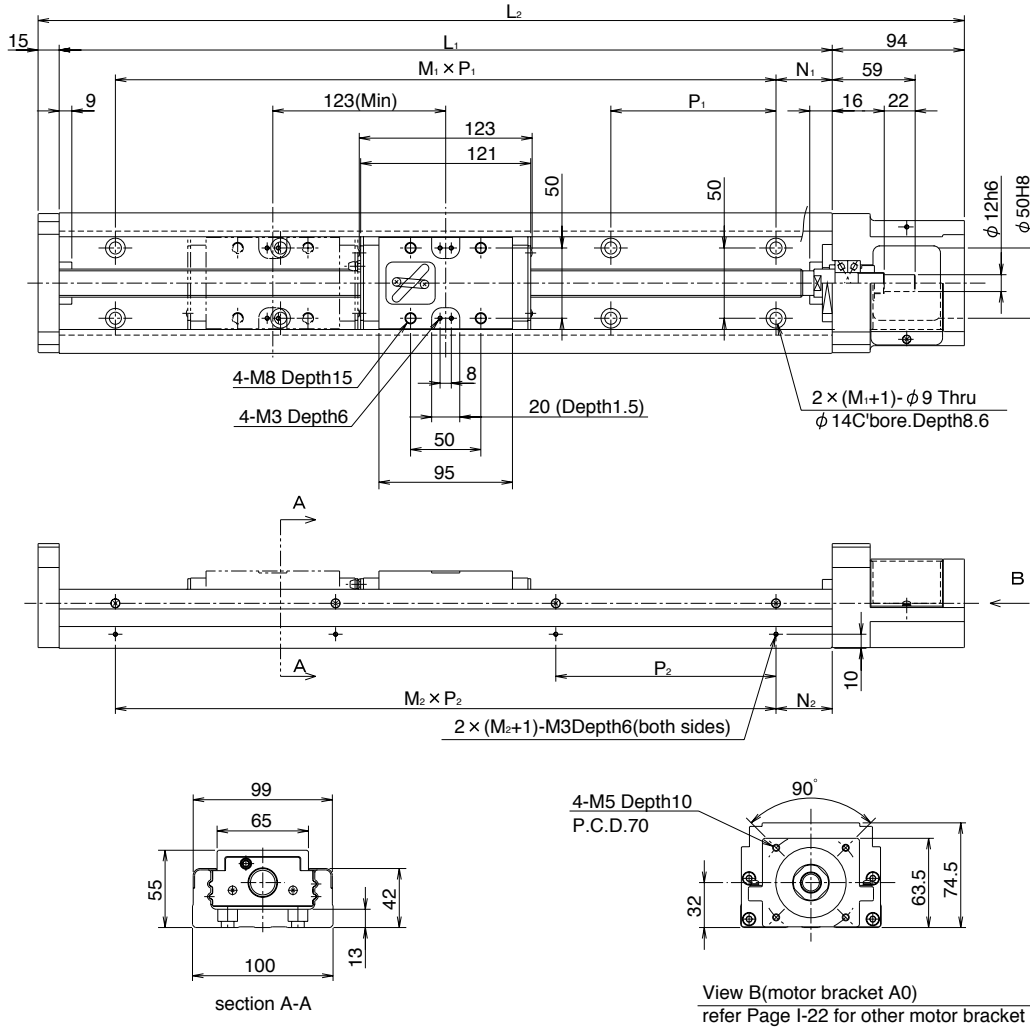



## -With Top-Cover-

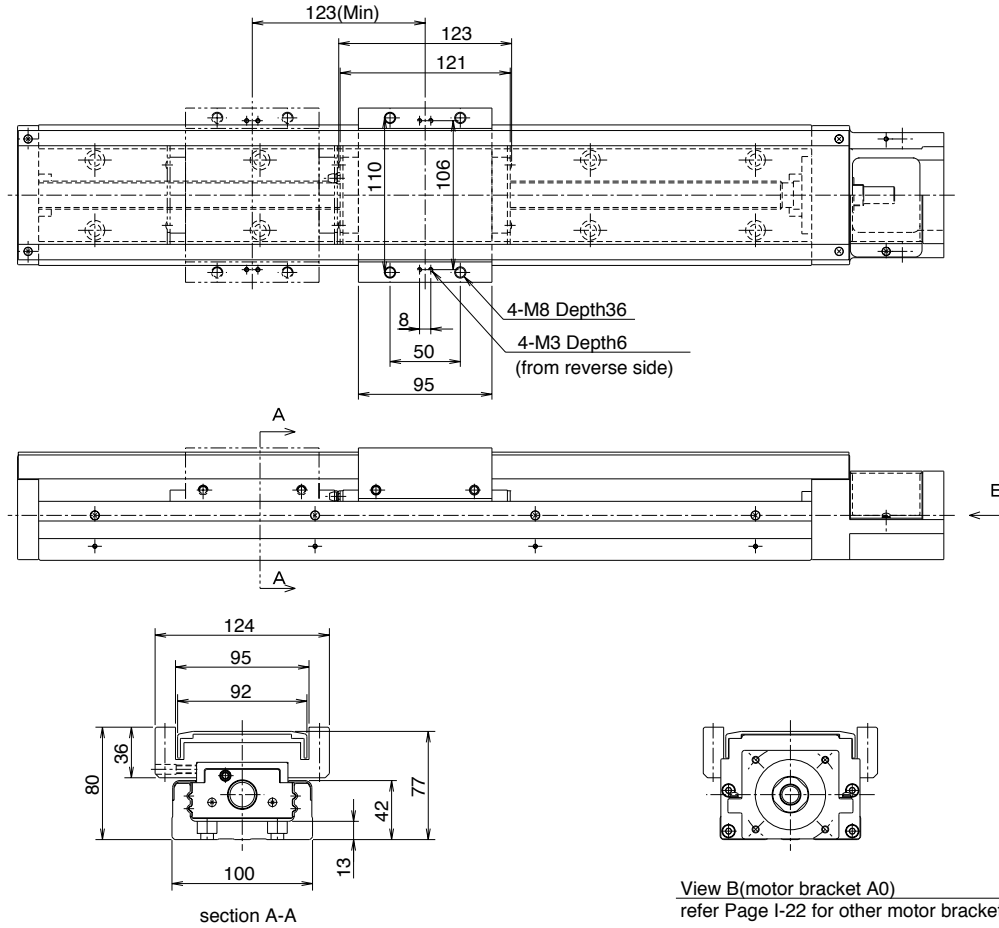

dimensions						stroke limit	
L <sub>1</sub>	L <sub>2</sub>	N <sub>1</sub>	M <sub>1</sub> × P <sub>1</sub>	N <sub>2</sub>	M <sub>2</sub> × P <sub>2</sub>	BG55A	BG55B
980	1089	40	6 × 150	90	4 × 200	834	711
1080	1189	15	7 × 150	40	5 × 200	934	811
1180	1289	65		90		1034	911
1280	1389	40	8 × 150	40	6 × 200	1134	1011
1380	1489	15	9 × 150	90		1234	1111

Stroke limit is traveling distance between both ends of the dampers.