

NB

NEW ITEM

SLIDE GUIDE

SEBS type

MINIATURE SLIDE GUIDE series

COMPLETING THE PRODUCT LINE-UP

SEBS3A/3AY SEBS3WA/3WAY



PACIFIC INTERNATIONAL BEARING SALES, INC.
800.228.8895 • WWW.PACIFICBEARINGSALES.COM



NIPPON BEARING CO., LTD.

STRUCTURE AND ADVANTAGES

NB's slide guide SEBS3A type consists of a block and a guide rail, both of which have two precision ground raceway grooves. The block consists of a main body, balls, and return caps.

Compact Design

The two raceway and four-point contact structure of the SEBS3A type minimize its height and give further advantage installation with limited space and reduces overall weight.

High Moment Loads

With the wide block (WA type), long block (AY type), and wide and long block combination(WAY type) are available and the versatile selection of blocks will realize an increase of moment capacity in your application.

Anti-Corrosion Type

The SEBS3A type slide guide uses Martensite stainless steel that is highly resistant to corrosion and

may be used in hostile environments.

Smooth Motion

Based on NB's manufacturing technology expertise for slide guide product, smooth linear motion movement is maintained evenly with the compact sized SEBS3A.

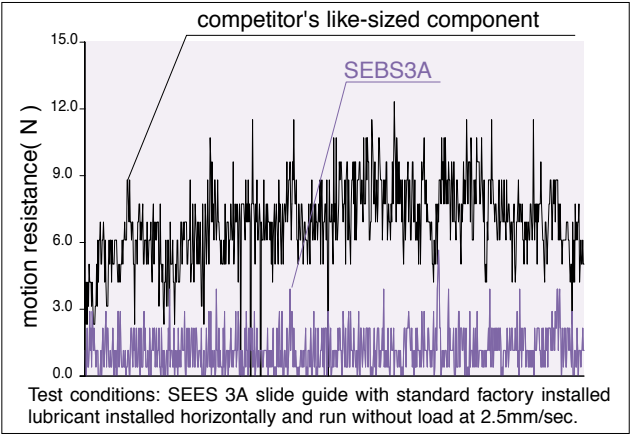

part number structure

example **SEBS 3A Y UU 2 T0 -100 P N / W2**

SEBS:anticorrosion	size	3A Standard	3WA Wide	block	blank standard	Y long	seal	blank without seal	UU seals on both ends	symbol for number of rails	blank single rail	W2 double rails	W3 triple rails	rail hole pattem	blank counterbore	N tapped hole	accuracy grade	blank high	P precision	total length of rail	pre-load symbol	T0 clearance +1~+3 μm
--------------------	------	-------------	----------	-------	----------------	--------	------	--------------------	-----------------------	----------------------------	-------------------	-----------------	-----------------	------------------	-------------------	---------------	----------------	------------	-------------	----------------------	-----------------	-----------------------

Note: The symbol for the number of rails does not mean the number of rails ordered.

ACCURACY

The SEBS 3A type slide guide is available in two grades of accuracy: high-grade (no symbol) and precision-grade (P).

Figure1 Accuracy unit/mm

accuracy grade	high	precision
accuracy symbol	none	P
allowable dimensional difference in height H	±0.020	±0.010
paired difference for height H	0.015	0.007
allowable dimensional difference in width W	±0.025	±0.015
paired difference for width W	0.020	0.010

part number	assembly dimensions			block dimensions						
	H	W	B	L ₁	L ₂	P _a	S _a	ℓ	L ₃	b
	mm	mm	mm	mm	mm	mm	mm	mm	mm	mm
SEBS 3A -N	4	2.5	8	10.5	11.8	3.5	M1.6	1.3	6.5	3
SEBS 3AY-N				14.5	15.8	5.5	M2		10.5	
SEBS 3WA	4.5	3	12	14.2	15	4.5	M2	1.7	9.7	3.5
SEBS 3WAY				19	19.8	8			14.5	
SEBS 3WA -N	4.5	3	12	14.2	15	4.5	M2	1.7	9.7	3.5
SEBS 3WAY-N				19	19.8	8			14.5	

part number	standard rail length					maximum length
	L					
	mm					mm
SEBS 3A-N	30	40	60	80	100	150
SEBS 3WA	40	55	70	85	100	150
SEBS 3WA-N	40	55	70	85	100	150

Contact NB for rail length exceeds the maximum standard length listed in the dimensional tables.

MOUNTING BOLTS

Mounting bolts for SEBS3A are available from NB. M2 custom type bolts come with SEBS3WA and SEBS3WAY(mounting holes on the rail are counter-bore type).

Table2 Mounting Bolts

bolt type	size	D	H	pitch	ℓ
		mm	mm	mm	mm
cap screw	M2	3.8	2	0.4	4,5,6,8,10
custom screw	M2	3	0.6	0.4	6

Figure1 Mounting Bolts

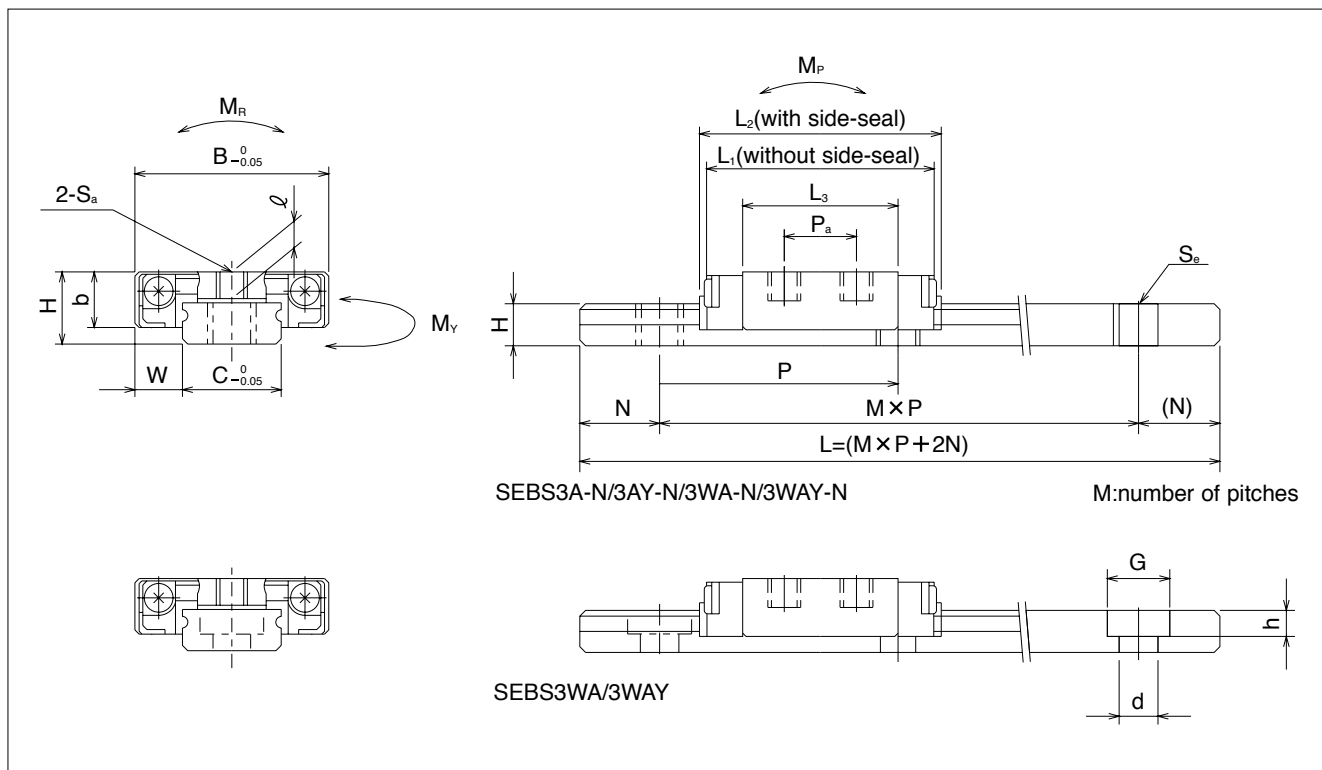
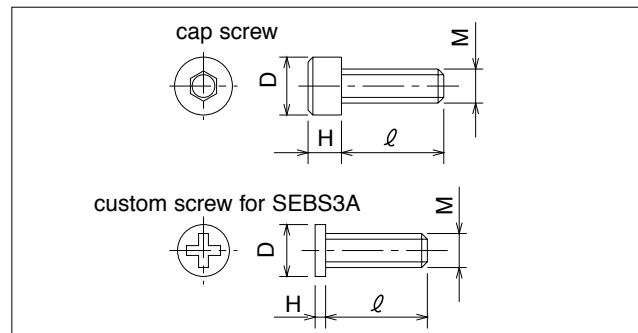

guide-rail dimensions						basic load rating		allowable static moment			mass		size
H1	C	Se	d x G x h	N	P	dynamic	static	M _P	M _Y	M _R	block	guide rail	
mm	mm		mm	mm	mm	C	C ₀	Nm	Nm	Nm	g	g/100mm	
2.6	3	M1.6	-	5	10	0.19	0.31	0.33	0.39	0.50	1.0	5.3	3A
						0.31	0.51	0.88	1.04	0.82	1.6		3AY
2.6	6	-	2.4 x 4 x 1.5	5	15	0.28	0.47	0.82	0.89	1.46	2.4	11.0	3WA
						0.42	0.71	1.70	2.02	2.20	3.4		3WAY
2.6	6	M3	-	5	15	0.28	0.47	0.82	0.89	1.46	2.4	11.0	3WA
						0.42	0.71	1.70	2.02	2.20	3.4		3WAY



INSTALLATION

Shapes of mounting planes

Slide Guides are generally mounted by pushing the reference surface of the rail and block against the shoulder of the mounting surface.

An escape groove should be provided at the corner of the shoulder in order to avoid interference with the corner of the rail or block.

Figure2 Mounting Reference Surface Shapes-1

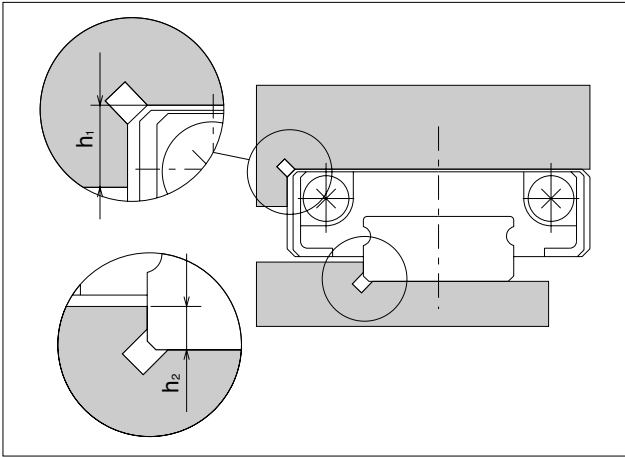

Table3 Shoulder height of mounting unit:mm

part number	shoulder height table	shoulder height rail
	h_1	h_2
SEBS3A, 3AY	1.2	0.8
SEBS3WA, 3WAY	1.5	0.8

Recommended tightening torque

The bolts used to secure the rail should be tightened using a torque wrench. The recommended torque values are given in Table5.

Figure3 Mounting Reference Surface Shapes-2

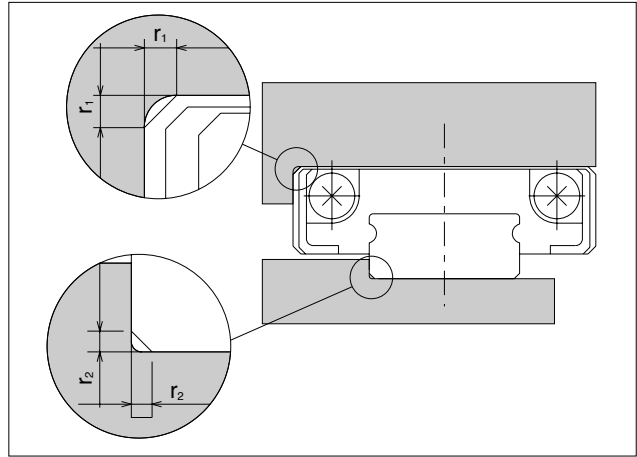

Table4 Maximum corner radius unit:mm

part number	installed table	installed rail
	r_1	r_2
SEBS3A, 3AY	0.15	0.1
SEBS3WA, 3WAY	0.15	0.1

Table5 Recommended Tightening Torque unit:N · m

part number	bolt size	recommended torque
SEBS3A-N, 3AY-N	M1.6	0.15
SEBS3WA, 3WAY	M2	0.31
SEBS3WA-N, 3WAY-N	M3	1.0



NIPPON BEARING CO., LTD.



PACIFIC INTERNATIONAL BEARING SALES, INC.
800.228.8895 • WWW.PACIFICBEARINGSALES.COM

No.5540

First Edition:Apr.30,2003

*Specifications are subject to change without notice.