

SH-A TYPE

– Shaft End Supporter – (Aluminum)

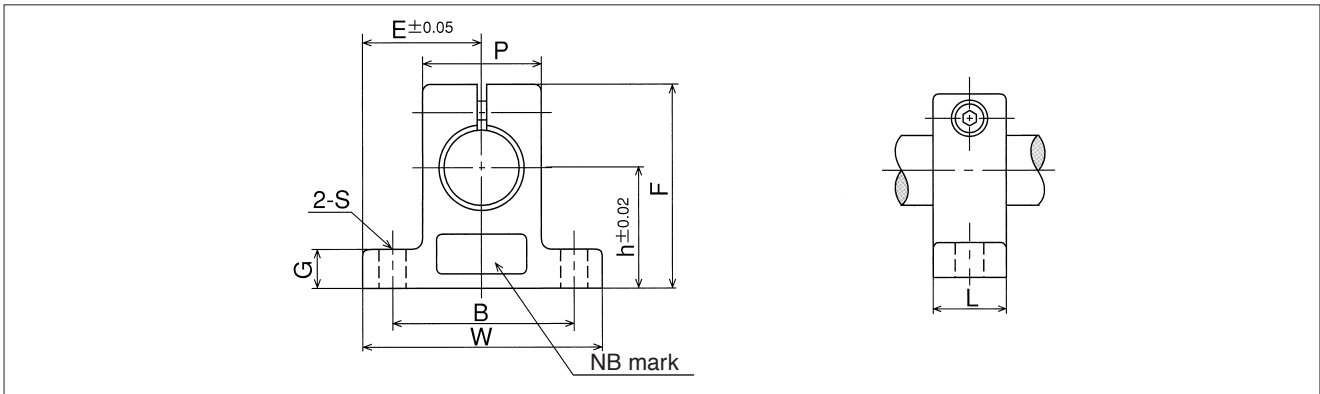

part number	shaft diameter mm	major dimensions									adjusting bolt size	mass g
		h mm	E mm	W mm	L mm	F mm	G mm	P mm	B mm	S (bolt size) mm		
SH 8A	8	20	21	42	14	32.8	6	18	32	5.5(M 5)	M 4	24
SH10A	10	20	21	42	14	32.8	6	18	32	5.5(M 5)	M 4	24
SH12A	12	23	21	42	14	37.5	6	20	32	5.5(M 5)	M 4	30
SH13A	13	23	21	42	14	37.5	6	20	32	5.5(M 5)	M 4	30
SH16A	16	27	24	48	16	44	8	25	38	5.5(M 5)	M 4	40
SH20A	20	31	30	60	20	51	10	30	45	6.6(M 6)	M 5	70
SH25A	25	35	35	70	24	60	12	38	56	6.6(M 6)	M 6	130
SH30A	30	42	42	84	28	70	12	44	64	9 (M 8)	M 6	180
SH35A	35	50	49	98	32	82	15	50	74	11 (M10)	M 8	270
SH40A	40	60	57	114	36	96	15	60	90	11 (M10)	M 8	420
SH50A	50	70	63	126	40	120	18	74	100	14 (M12)	M12	750
SH60A	60	80	74	148	45	136	18	90	120	14 (M12)	M12	1,100

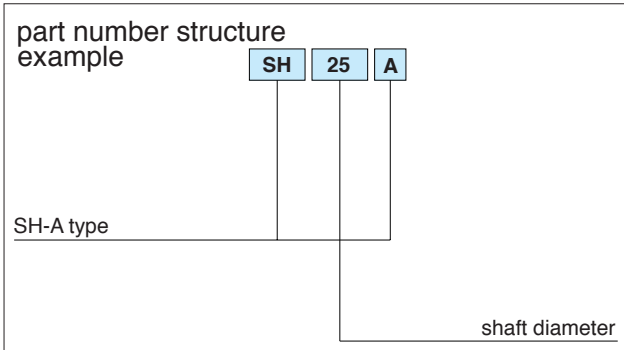
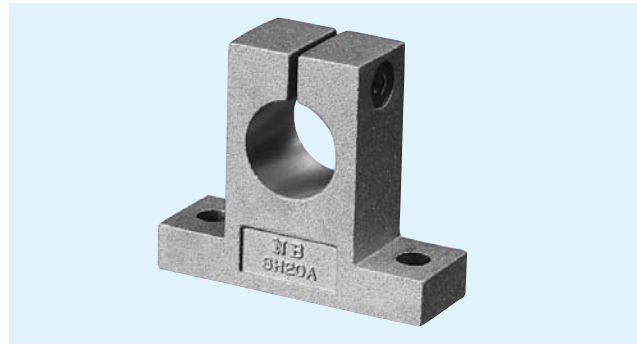

SH TYPE

– Shaft End Supporter – (Cast Iron)

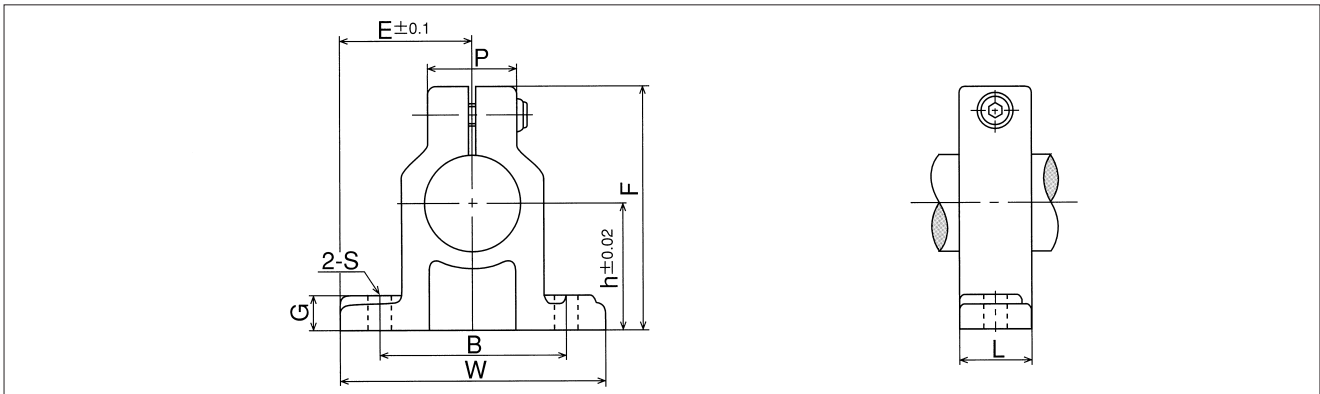
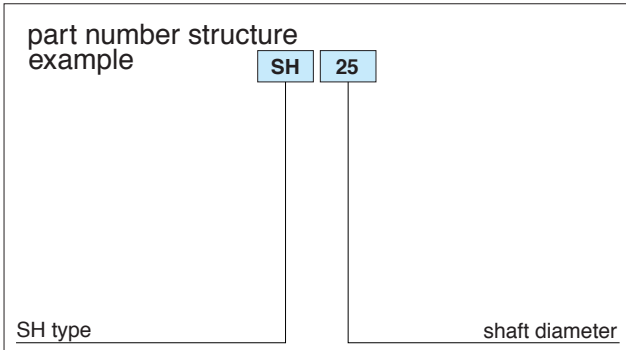

part number	shaft diameter mm	major dimensions									adjusting bolt size	mass g
		h mm	E mm	W mm	L mm	F mm	G mm	P mm	B mm	S (bolt size) mm		
SH10	10	20	22	44	15	35	7	19	32	4.5(M 4)	M 4	80
SH13	13	23	25	50	17	40	8	17	32	7 (M 5)	M 4	120
SH16	16	27	27.5	55	17	45	10	16	38	7 (M 5)	M 4	120
SH20	20	31	32.5	65	20	53	12	22	45	8 (M 6)	M 5	190
SH25	25	35	38	76	24	61	12	24	56	8 (M 6)	M 6	300
SH30	30	42	42.5	85	28	73	15	28	64	10 (M 8)	M 6	490
SH35	35	50	50	100	32	87	15	34	74	12 (M10)	M 8	690
SH40	40	60	60	120	36	104	18	38	90	12 (M10)	M10	1,200
SH50	50	70	70	140	40	122	20	48	100	14 (M12)	M12	1,700
SH60	60	80	82.5	165	45	140	23	58	120	14 (M12)	M12	2,500



SA TYPE

– Shaft Support Rail –

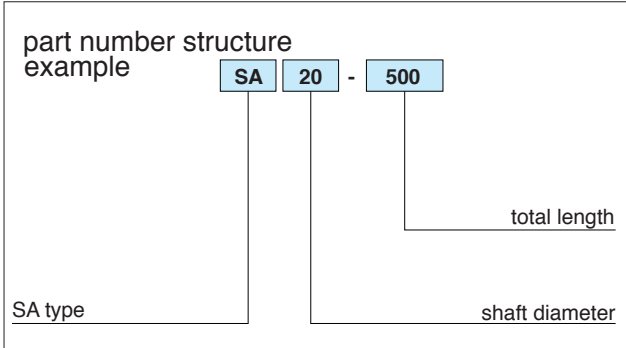
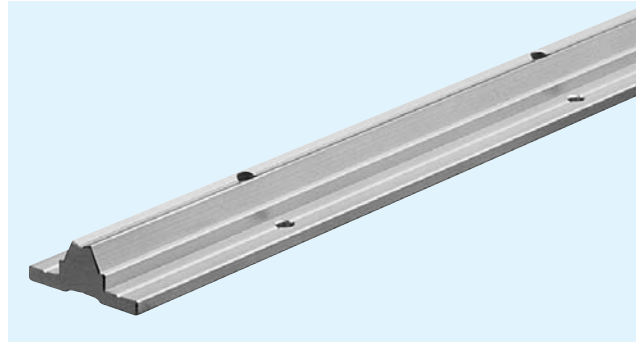

part number	shaft diameter mm	major dimensions														mass g	
		H mm	E mm	W mm	L mm	F mm	T mm	K mm	J mm	h ₁ mm	θ	B mm	N mm	M×P mm	S ₁ mm		S ₂ (bolt size)
SA10-200	10	18	16	32	200	13.5	4	8.9	12.4	4.7	80°	22	50	1×100	4.5	M4	110
SA10-300					300								50	2×100			160
SA10-400					400								50	3×100			220
SA10-500					500								50	4×100			270
SA10-600					600								50	5×100			330
SA13-200	13	21	17	34	200	15	4.5	9.8	15	6	80°	25	50	1×100	4.5	M4	140
SA13-300					300								50	2×100			210
SA13-400					400								50	3×100			280
SA13-500					500								50	4×100			350
SA13-600					600								50	5×100			420
SA16-200	16	25	20	40	200	17.8	5	11.7	18.5	8	80°	30	25	1×150	5.5	M5	200
SA16-300					300								75	1×150			300
SA16-400					400								50	2×150			400
SA16-500					500								25	3×150			500
SA16-600					600								75	3×150			600
SA20-200	20	27	22.5	45	200	17.7	5	10	19	8	50°	30	25	1×150	5.5	M6	200
SA20-300					300								75	1×150			300
SA20-400					400								50	2×150			400
SA20-500					500								25	3×150			510
SA20-600					600								75	3×150			610
SA25-200	25	33	27.5	55	200	21	6	12	21.5	8	50°	35	25	1×150	6.5	M6	290
SA25-300					300								50	1×200			430
SA25-400					400								100	1×200			580
SA25-500					500								50	2×200			730
SA25-600					600								100	2×200			880



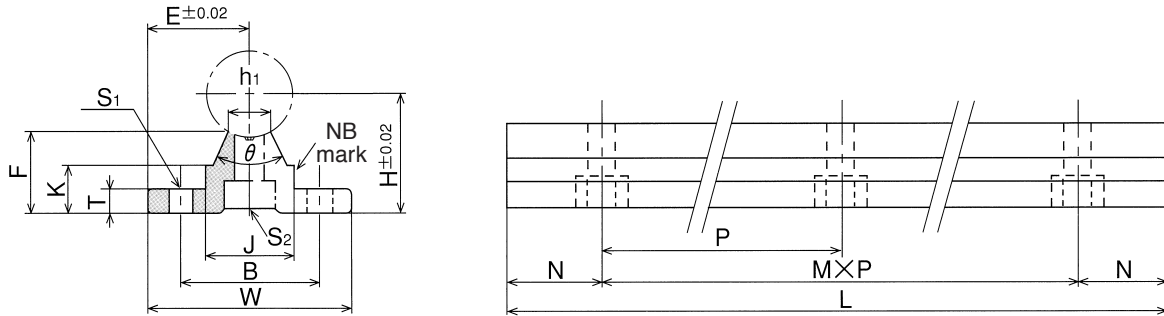

※ Mounting bolts for pre-drilled shaft are included.

part number	shaft diameter mm	major dimensions														mass g	
		H mm	E mm	W mm	L mm	F mm	T mm	K mm	J mm	h ₁ mm	θ	B mm	N mm	M×P mm	S ₁ mm		S ₂ (bolt size)
SA30-200	30	37	30	60	200	22.8	7	13	26.5	10.3	50°	40	25	1×150	6.5	M 8	360
SA30-300					300								50	1×200			550
SA30-400					400								100	1×200			730
SA30-500					500								50	2×200			920
SA30-600					600								100	2×200			1,100
SA35-200	35	43	32.5	65	200	26.5	8	15.5	28	13	50°	45	25	1×150	9	M 8	460
SA35-300					300								50	1×200			700
SA35-400					400								100	1×200			950
SA35-500					500								50	2×200			1,190
SA35-600					600								100	2×200			1,420
SA40-200	40	48	37.5	75	200	29.4	9	17	38	16	50°	55	25	1×150	9	M 8	630
SA40-300					300								75	1×150			960
SA40-400					400								50	1×300			1,290
SA40-500					500								100	1×300			1,610
SA40-600					600								150	1×300			1,950
SA50-200	50	62	47.5	95	200	38.8	11	21	45	20	50°	70	25	1×150	11	M10	1,000
SA50-300					300								75	1×150			1,500
SA50-400					400								50	1×300			2,000
SA50-500					500								100	1×300			2,500
SA50-600					600								150	1×300			3,000

