

NB

NEW

SLIDE WAY

RV type
GONIO WAY

Standardized radius slide way

High precision, low friction, easy handling



PACIFIC INTERNATIONAL BEARING SALES, INC.
800.228.8895 • WWW.PACIFICBEARINGSALES.COM



NIPPON BEARING CO., LTD.



GONIO WAY RV type

NB's long standing technological leadership in Slide Way product, has brought about a new product to address radius movement.

NB's GONIO WAY (RV type) is a non re-circulating crossed roller bearing providing low friction radius movement. The RV type is ideal for applications where sweeping movement or precise angular positioning is required without changing rotation center, such as in optical equipment and measuring devices.

STRUCTURE AND FEATURES

NB's RV type slide way consists of precision ground, hardened, curved, i V" shape rails, and curved roller cages in which cross rollers are fitted. Precision cross roller design minimizes frictional resistance providing for stabilized curved movement with extremely low friction.

LOW FRICTION / PRECISE MOVEMENT

Precision grinding and curved roller cage allow for low elements friction with negligible difference between static and dynamic friction. This feature provides for precise curved movement and fine feed.

HIGH RIGIDITY / HIGH LOAD

Greater surface contact area from cross roller design and provides hardened ground rails allow for less elastic deformation and provides high rigidity and load capacity.

EASE OF INSTALLATION

NB's unique curved roller cage retains precision cross roller easing in the installation process. RV type consists of four rails, two cages, and eight end pieces as one set.

LOW NOISE

The non re-circulating design and non-contact between rollers for extremely low noise.

Fig.1. Structure of RV type

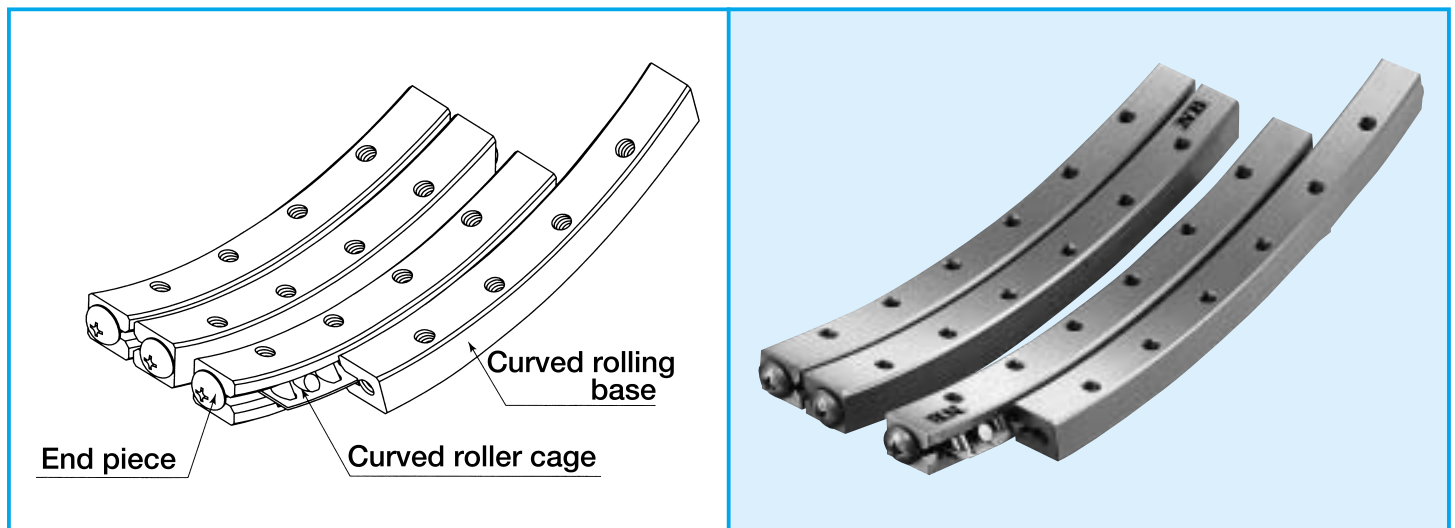



ACCURACY

RV's accuracy for overall length is measured as shown in figure 2

Table 1. Accuracy

| Part No. | Accuracy sm |
|------------|-------------|
| RV2040-50 | 10 |
| RV2060-60 | 10 |
| RV3070-90 | 10 |
| RV3070-110 | 10 |
| RV3100-160 | 10 |

Fig. 2. Reference planes

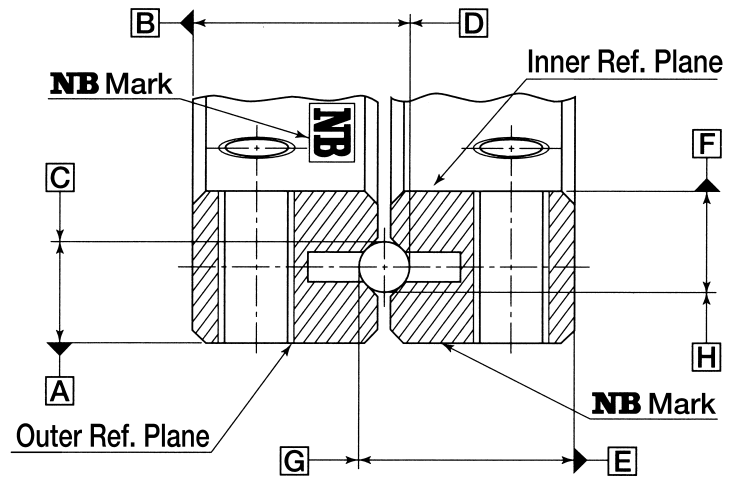

The reference surfaces are located on the opposite side of the "NB" mark. There are inner reference planes and outer reference planes in one set of RV.

RATED LIFE

Rated life of RV type slide way is given by the following formula.

$$\text{RATED LIFE } L = \left(\frac{f_r}{f_w} \cdot \frac{C}{P} \right)^{\frac{10}{3}} \cdot 50$$

L: Rated life (km) f_r : Temperature coefficient f_w : Load coefficient
C: Basic dynamic load rating (N) P: Working load (N)

TEMPERATURE COEFFICIENT f_r

NB's RV type is hardened to increase rigidity so wear and tear are minimized. Applications where temperatures will reach 100°C or higher, the hardness and load rating will decrease accordingly. A change in hardness corresponding to the change in temperature is graphed in figure 3 by denoting temperature coefficient f_r .

LOAD COEFFICIENT f_w

To calculate Load rating of RV TYPE, it is necessary to obtain the mass of work-piece, inertia arising from travel speed, moment, and also the change from time to time of all factors. With radius travel, it is difficult to calculate exact load due to uncertain factors such as repetition of starts-stops, vibration and shock from environment, etc. Load coefficient f_w is shown in Table 2.

LIFE SPAN

$$L_H = \frac{L \cdot 10^3}{2 \cdot l_s \cdot n_1 \cdot 60}$$

L_w : Life (hour) l_s : Stroke(m)
 n_1 : Numbers of travel per minute (cpm)

Fig. 3. Temperature coefficient f_r

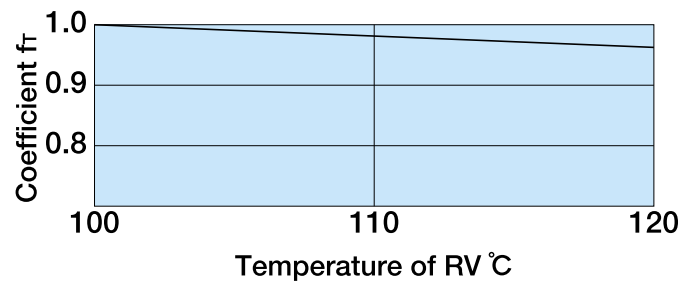

Table 2. Load coefficient f_w

| Coefficient | | Load Coefficient |
|--------------------------------------|------------------|------------------|
| Load | Speed | |
| Without impulsive shock or vibration | 15m/min. or less | 1.0-1.5 |
| With impulsive shock or vibration | 30m/min or less | 1.5-2.0 |



INSTALLATION

Fig. 4. Example of installation

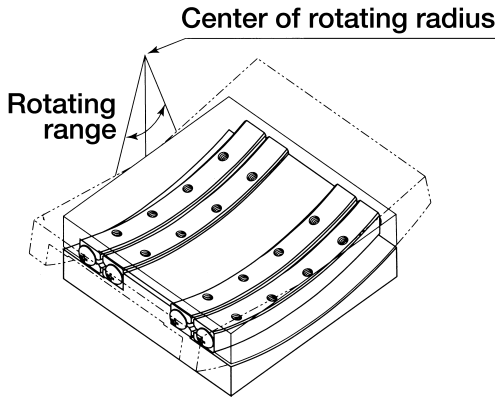

ACCURACY OF INSTALLATION SURFACES

To achieve sufficient performance of NB's RV TYPE, it is advised to finish installation surface in same or higher accuracy to that of RV TYPE.

INSTALLATION PROCEDURES

- (1) Remove burr, flaw, and debris on curved installation surface of table and bed to keep clean from foreign materials while installation work is conducted.
- (2) Stabilize rails shown as j , k and l by tightening torque as instructed (Table 3, page 4) (Fig. 6 a)
- (3) Tighten rail shown as m temporarily. (Fig. 6 b)
- (4) Remove end pieces from one end, insert curved roller cage slowly until it reaches middle position. (Fig. 6 c)
- (5) Replace the end pieces once fitted above.
- (6) Move the table to maximum stroke end to left and right and adjust curved roller cage come to the center of the rail assembly.
- (7) Fit indicator to side of the table (reference plane side) . (Fig 6 d)
- (8) Move the table to stroke end of one side and tighten adjust screw on curved roller cage lightly. (Fig. 7 e)
- (9) Move the table to stroke end of the opposite side and tighten adjust screw slightly. (Fig. 7 f)
- (10) Move the table to the center position and tighten adjust screw at center position slightly. (Fig. 7 g)

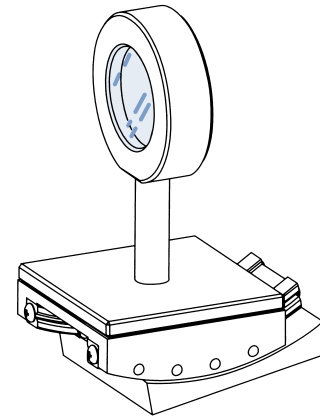

Fig. 5. Accuracy of installation surfaces

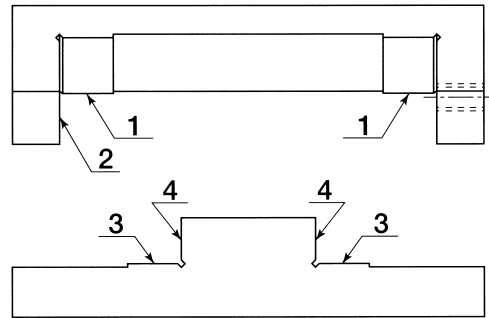

Fig. 6. Installation method (1)

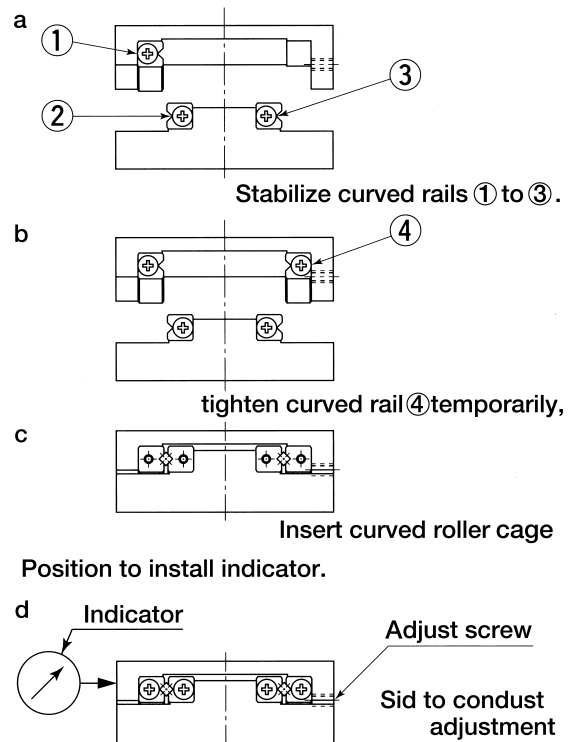

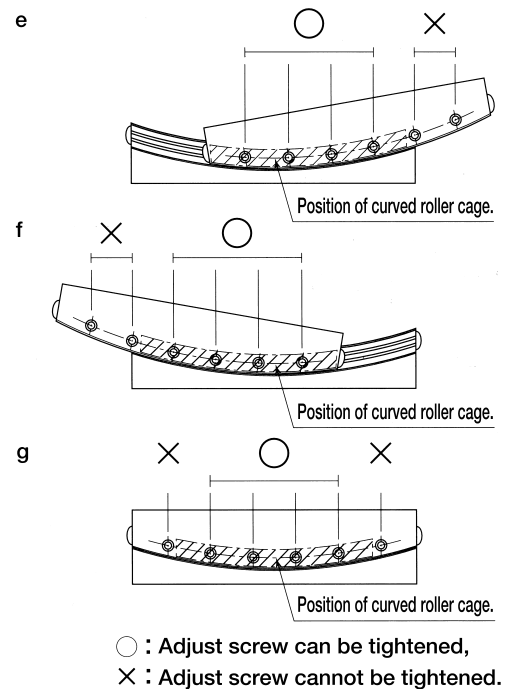

Fig. 7. Installation method(2)

- (11) Repeat above procedures from (8) through (10) until no play is confirmed.
Once no more play exists, oscillation of the indicator becomes stabilized at minimum value, when the table is moved to left and right. Please take caution not to apply excessive pre-load.
- (12) Conduct final adjustment for pre-load. In the manner described on above procedures from (8) through (10), tighten adjust screw by torque wrench following the torque recommended in Table 3.
- (13) Finally, stabilize rail m, which is fitted temporarily. Installation bolts for rail m should be tightened in same sequence as adjust screws.

Table 3. Recommended tightening torque
Unit:Nbm

| Part No. | Nominal screw size | Tightening torque |
|----------|--------------------|-------------------|
| RV 2 | M3 | 2 |
| RV 3 | | |



PRECAUTIONS FOR USE

LUBRICATION

NB's RV TYPE contains a lithium soap-based grease and can be used as delivered. As use continues of lubricate as required depending upon operating conditions.

DUST PREVENTION

Depending upon the operating environment, dust and debris may be able to invade RV TYPE and disrupt the ideal operating performance. Therefore it is advised to protect the RV TYPE with covers or bellows if such a harsh environment exists.

OPERATING ENVIRONMENT (Temperature)

For RV TYPE, the recommended ambient working temperature is between -20 8 and 110 8 .

ADJUSTMENT

Install and adjust RV TYPE carefully.

When accuracy of installation surfaces and/or adjustment of pre-load are insufficient, RV TYPE motion accuracy can be deteriorated and thus, can cause to skew movement and may reduce performance and life.

CAGE CREEP

When the RV TYPE is used in an application where high speed, vibration, or an unbalanced load is present, the cage would go out of position. To minimize cage creep, allow for extra stroke distance prevent from excess of pre-load.

STOPPER

End pieces are fitted at both ends of RV RAIL to prevent the RV TYPE roller cage from existing out.

CAREFUL HANDLING

Rough handling will affect the precision performance of the RV TYPE. Handle as a precision components.

USE AS A SET

RV TYPE is supplied as a set of rails (4), roller cages (2), and stoppers (8),and should not be mixed with other sets.

CUSTOM SPECIFICATION

NB accepts custom requests for RV TYPE SLIDE WAY such as; length of rail, radius of rotation, radius stroke range, number of rollers fitted and so on. If custom RV TYPE are required, please contact NB for further assistance.



CR TYPE

(Standard curved roller cage)
-CR2/CR3-

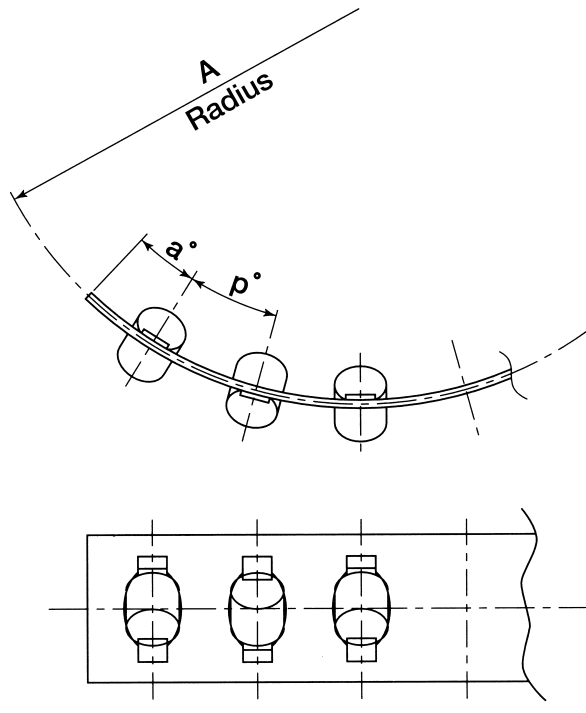
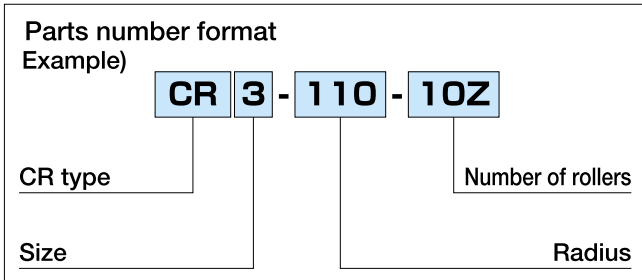
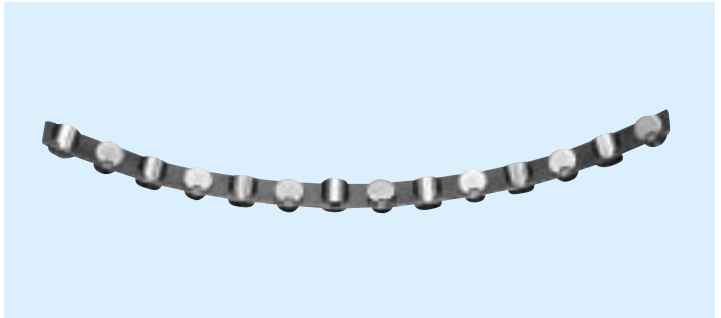

| Parts Number | Roller Dia. D mm | Radius A mm | t mm | W mm | p | a |
|---------------|------------------------|-------------------|---------|---------|------|------|
| CR2- 50- 7Z | 2 | 50 | 0.3 | 5.6 | 4.6w | 2.9w |
| CR2- 60-12Z | 2 | 60 | 0.3 | 5.6 | 3.8w | 2.4w |
| CR3- 90-11Z | 3 | 90 | 0.4 | 7.2 | 3.2w | 1.9w |
| CR3- 110- 10Z | 3 | 110 | 0.4 | 7.2 | 2.6w | 1.6w |
| CR3-160-14Z | 3 | 160 | 0.4 | 7.2 | 1.8w | 1.1w |



RV TYPE

-RV2 / RV3-

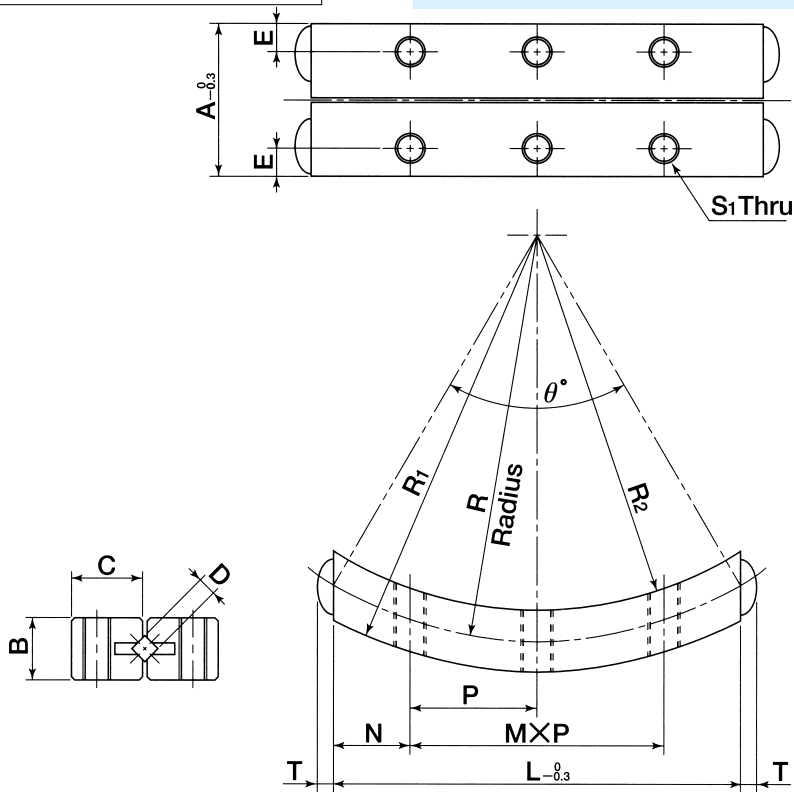
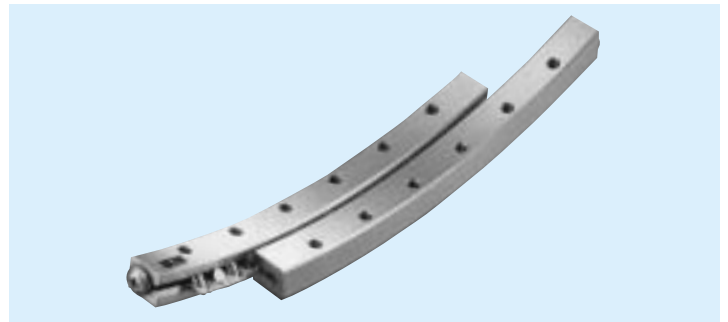
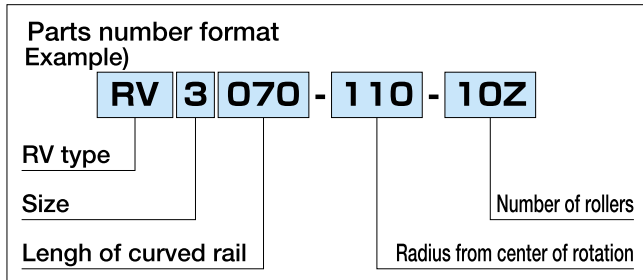

Rails (4), Roller Cages (2), Stoppers (8) are provided as a set of RV TYPE.

| Parts Number | Rotating Range | Roller Dia. D mm | Number of Rollers. Z | Major Dimensions | | | | | | | | | | | | | | Basic Load Rating | | Weight g |
|----------------|----------------|------------------|----------------------|------------------|------|-------------------|-------------------|------|------|------|---------|-------|------|----------------|------|-------|------------------------|------------------------|-----|----------|
| | | | | L mm | R mm | R ₁ mm | R ₂ mm | A mm | B mm | C mm | Ma P mm | N mm | E mm | S ₁ | T mm | t | Dynamic C _N | Static Co _N | | |
| RV2040- 50- 7Z | e 10w | 2 | 7 | 40 | 50 | 53 | 47 | 15 | 6 | 7.25 | 2a 12.5 | 7.5 | 2.5 | M3 | 1.5 | 47.2w | 802 | 878 | 49 | |
| RV2060- 60-12Z | e 10w | 2 | 12 | 60 | 60 | 63 | 57 | 15 | 6 | 7.25 | 3a 12.5 | 11.25 | 2.5 | M3 | 1.5 | 60.0w | 1176 | 1464 | 75 | |
| RV3070- 90-11Z | e 10w | 3 | 11 | 70 | 90 | 94 | 86 | 18 | 8 | 8.5 | 3a 15 | 12.5 | 3 | M3 | 1.9 | 45.8w | 2632 | 3516 | 137 | |
| RV3070-110-10Z | e 10w | 3 | 10 | 70 | 110 | 114 | 106 | 18 | 8 | 8.5 | 3a 15 | 12.5 | 3 | M3 | 1.9 | 37.1w | 2632 | 3516 | 135 | |
| RV3100-160-14Z | e 10w | 3 | 14 | 100 | 160 | 164 | 156 | 18 | 8 | 8.5 | 5a 15 | 12.5 | 3 | M3 | 1.9 | 36.4w | 3388 | 4923 | 193 | |

1N6 0.102kgf