

SMF TYPE

— Round Flange Type —

This type is a metric dimension series widely used in Japan and other countries.

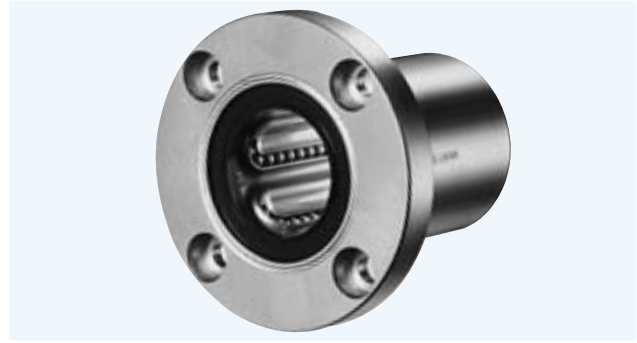

part number structure													
example	SMSF 25 G UU - SK												
specification	<table border="1"> <tr> <td>SMF</td> <td>standard</td> </tr> <tr> <td>SMSF</td> <td>anticorrosion</td> </tr> </table>	SMF	standard	SMSF	anticorrosion								
SMF	standard												
SMSF	anticorrosion												
inner contact diameter													
retainer material	<table border="1"> <tr> <td>blank</td> <td>steel</td> </tr> <tr> <td>G</td> <td>resin</td> </tr> </table>	blank	steel	G	resin								
blank	steel												
G	resin												
	<table border="1"> <tr> <td colspan="2">outer cylinder surface treatment</td> </tr> <tr> <td>blank</td> <td>no surface treatment</td> </tr> <tr> <td>SK</td> <td>electroless nickel plating</td> </tr> <tr> <td>RD</td> <td>Raydent treatment</td> </tr> <tr> <td>SB</td> <td>black oxide*</td> </tr> <tr> <td>SC</td> <td>industrial chrome plating</td> </tr> </table> <p>*not available in SMSF type</p>	outer cylinder surface treatment		blank	no surface treatment	SK	electroless nickel plating	RD	Raydent treatment	SB	black oxide*	SC	industrial chrome plating
outer cylinder surface treatment													
blank	no surface treatment												
SK	electroless nickel plating												
RD	Raydent treatment												
SB	black oxide*												
SC	industrial chrome plating												
	<table border="1"> <tr> <td colspan="2">seal</td> </tr> <tr> <td>blank</td> <td>without seal</td> </tr> <tr> <td>UU</td> <td>seals on both sides</td> </tr> </table>	seal		blank	without seal	UU	seals on both sides						
seal													
blank	without seal												
UU	seals on both sides												

part number				dr		D		L	
standard		anticorrosion		mm	tolerance μm	mm	tolerance μm	±0.3 mm	
steel retainer	resin retainer	stainless retainer	resin retainer						
SMF 6	SMF 6G	SMSF 6	SMSF 6G	6	0 - 9	12	0 - 13	19	
SMF 8s	SMF8sG	SMSF8s	SMSF8sG	8		15		17	
SMF 8	SMF 8G	SMSF 8	SMSF 8G	8		15		24	
SMF 10	SMF10G	SMSF10	SMSF10G	10		19	0 - 16	29	
SMF 12	SMF12G	SMSF12	SMSF12G	12		21		30	
SMF 13	SMF13G	SMSF13	SMSF13G	13		23		32	
SMF 16	SMF16G	SMSF16	SMSF16G	16		28		37	
SMF 20	SMF20G	SMSF20	SMSF20G	20		0 - 10	32	0 - 19	42
SMF 25	SMF25G	SMSF25	SMSF25G	25			40		59
SMF 30	SMF30G	SMSF30	SMSF30G	30		0 - 12	45	0 - 22	64
SMF 35	SMF35G	SMSF35	SMSF35G	35	52		70		
SMF 40	SMF40G	SMSF40	SMSF40G	40	60		80		
SMF 50	SMF50G	SMSF50	SMSF50G	50	0 - 15	80	0 - 25	100	
SMF 60	SMF60G	SMSF60	SMSF60G	60		90		110	
SMF 80	—	—	—	80	0/- 20	120	0/- 29	140	
SMF100	—	—	—	100		150		175	



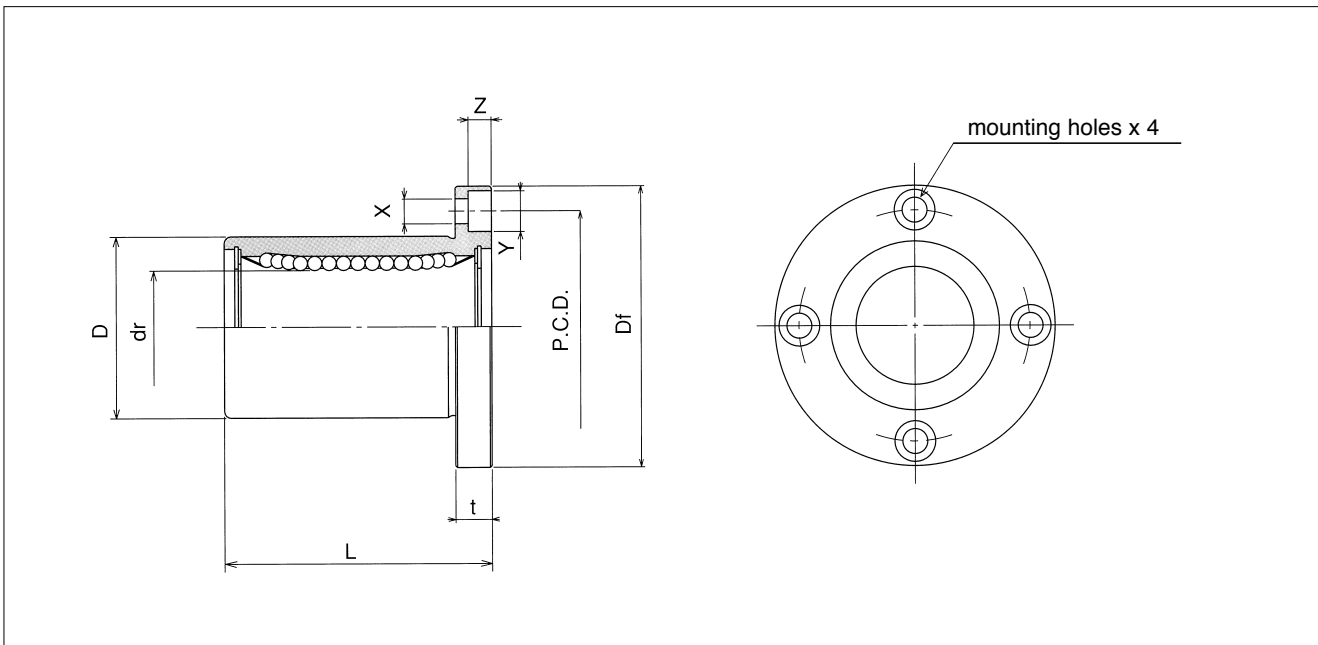

major dimensions				eccentricity	perpen- dicularity	basic load rating		mass	shaft diameter
flange						dynamic C N	static Co N		
Df mm	t mm	P.C.D. mm	X×Y×Z mm	μm	μm				
28	5	20	3.5×6×3.1	12	12	206	265	24	6
32	5	24	3.5×6×3.1			176	216	32	8
32	5	24	3.5×6×3.1			274	392	37	8
40	6	29	4.5×7.5×4.1			372	549	72	10
42	6	32	4.5×7.5×4.1			510	784	76	12
43	6	33	4.5×7.5×4.1			510	784	88	13
48	6	38	4.5×7.5×4.1			774	1,180	120	16
54	8	43	5.5×9×5.1	15	15	882	1,370	180	20
62	8	51	5.5×9×5.1			980	1,570	340	25
74	10	60	6.6×11×6.1			1,570	2,740	470	30
82	10	67	6.6×11×6.1	20	20	1,670	3,140	650	35
96	13	78	9×14×8.1			2,160	4,020	1,060	40
116	13	98	9×14×8.1			3,820	7,940	2,200	50
134	18	112	11×17×11.1	25	25	4,700	10,000	3,000	60
164	18	142	11×17×11.1			7,350	16,000	5,800	80
200	20	175	14×20×13.1			14,100	34,800	10,600	100

1N ≅ 0.102kgf



PACIFIC INTERNATIONAL BEARING SALES, INC.
800.228.8895 • WWW.PACIFICBEARINGSALES.COM

SMK TYPE

– Square Flange Type –

This type is a metric dimension series widely used in Japan and other countries.

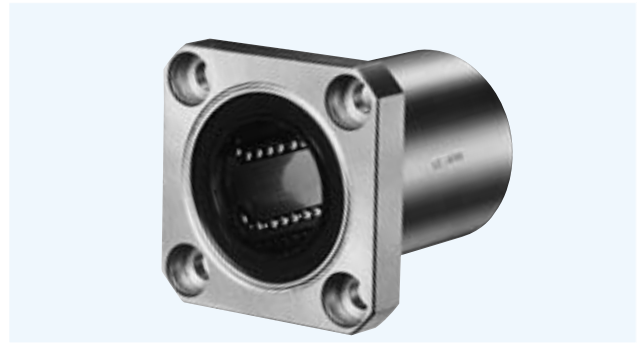

part number structure											
example	SMSK 25 G UU - SK										
specification	<table border="1"> <tr> <td>SMK</td> <td>standard</td> </tr> <tr> <td>SMSK</td> <td>anticorrosion</td> </tr> </table>	SMK	standard	SMSK	anticorrosion						
SMK	standard										
SMSK	anticorrosion										
inner contact diameter											
retainer material	<table border="1"> <tr> <td>blank</td> <td>steel</td> </tr> <tr> <td>G</td> <td>resin</td> </tr> </table>	blank	steel	G	resin						
blank	steel										
G	resin										
outer cylinder surface treatment	<table border="1"> <tr> <td>blank</td> <td>no surface treatment</td> </tr> <tr> <td>SK</td> <td>electroless nickel plating</td> </tr> <tr> <td>RD</td> <td>Raydent treatment</td> </tr> <tr> <td>SB</td> <td>black oxide*</td> </tr> <tr> <td>SC</td> <td>industrial chrome plating</td> </tr> </table>	blank	no surface treatment	SK	electroless nickel plating	RD	Raydent treatment	SB	black oxide*	SC	industrial chrome plating
blank	no surface treatment										
SK	electroless nickel plating										
RD	Raydent treatment										
SB	black oxide*										
SC	industrial chrome plating										
*not available in SMSK type											
seal	<table border="1"> <tr> <td>blank</td> <td>without seal</td> </tr> <tr> <td>UU</td> <td>seals on both sides</td> </tr> </table>	blank	without seal	UU	seals on both sides						
blank	without seal										
UU	seals on both sides										

part number				dr		D		L	
standard		anticorrosion		mm	tolerance μm	mm	tolerance μm	±0.3 mm	
steel retainer	resin retainer	stainless retainer	resin retainer						
SMK 6	SMK 6G	SMSK 6	SMSK 6G	6	0 - 9	12	0 - 13	19	
SMK 8s	SMK8sG	SMSK8s	SMSK8sG	8		15		17	
SMK 8	SMK 8G	SMSK 8	SMSK 8G	8		15	24		
SMK 10	SMK10G	SMSK10	SMSK10G	10		19	29		
SMK 12	SMK12G	SMSK12	SMSK12G	12		21	0 - 16	30	
SMK 13	SMK13G	SMSK13	SMSK13G	13		23	32		
SMK 16	SMK16G	SMSK16	SMSK16G	16		28	37		
SMK 20	SMK20G	SMSK20	SMSK20G	20		0 - 10	32	0 - 19	42
SMK 25	SMK25G	SMSK25	SMSK25G	25		40	59		
SMK 30	SMK30G	SMSK30	SMSK30G	30		45	64		
SMK 35	SMK35G	SMSK35	SMSK35G	35	0 - 12	52	0 - 22	70	
SMK 40	SMK40G	SMSK40	SMSK40G	40	60	80			
SMK 50	SMK50G	SMSK50	SMSK50G	50	80	100			
SMK 60	SMK60G	SMSK60	SMSK60G	60	0 - 15	90	0 - 25	110	
SMK 80	—	—	—	80	120	140			
SMK100	—	—	—	100	0/- 20	150	0/- 29	175	



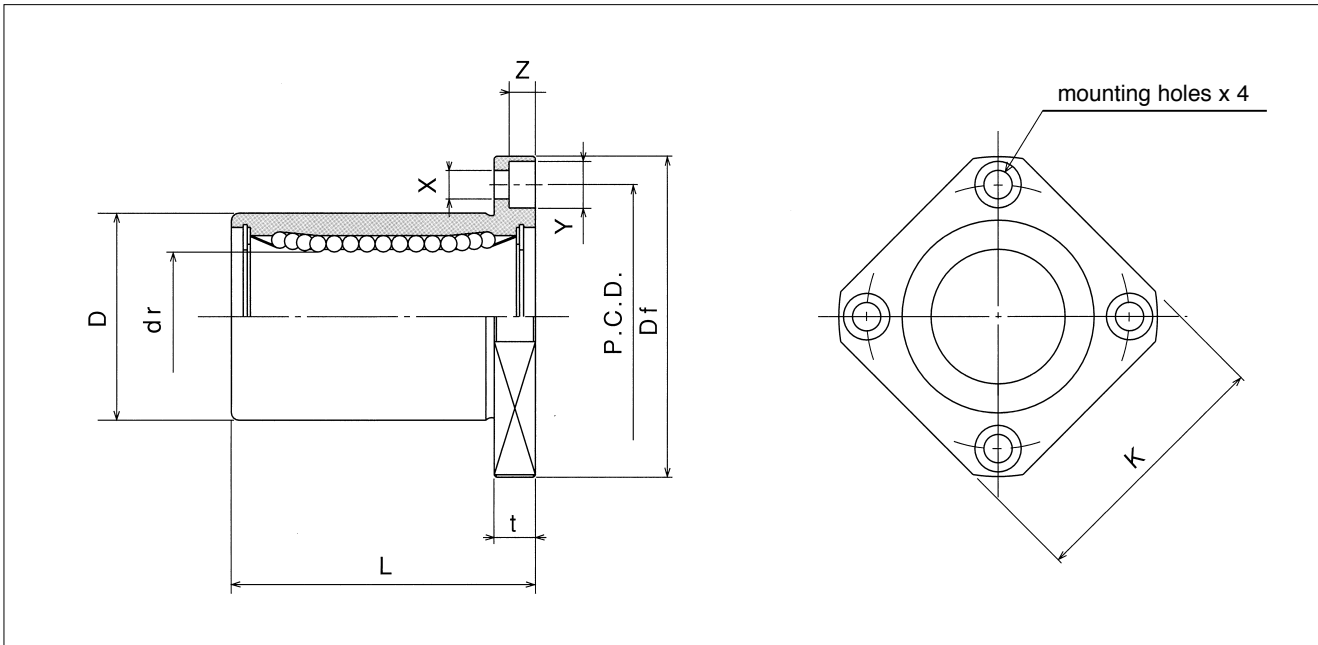

major dimensions					eccentricity	perpen- dicularity	basic load rating		mass	shaft diameter
flange							dynamic	static		
Df	K	t	P.C.D.	X×Y×Z	μm	μm			C	Co
mm	mm	mm	mm	mm			N	N		
28	22	5	20	3.5×6×3.1	12	12	206	265	18	6
32	25	5	24	3.5×6×3.1			176	216	24	8
32	25	5	24	3.5×6×3.1			274	392	29	8
40	30	6	29	4.5×7.5×4.1			372	549	52	10
42	32	6	32	4.5×7.5×4.1			510	784	57	12
43	34	6	33	4.5×7.5×4.1			510	784	72	13
48	37	6	38	4.5×7.5×4.1	15	15	774	1,180	104	16
54	42	8	43	5.5×9×5.1			882	1,370	145	20
62	50	8	51	5.5×9×5.1			980	1,570	300	25
74	58	10	60	6.6×11×6.1	20	20	1,570	2,740	375	30
82	64	10	67	6.6×11×6.1			1,670	3,140	560	35
96	75	13	78	9×14×8.1	25	25	2,160	4,020	880	40
116	92	13	98	9×14×8.1			3,820	7,940	2,000	50
134	106	18	112	11×17×11.1	30	30	4,700	10,000	2,560	60
164	136	18	142	11×17×11.1			7,350	16,000	5,300	80
200	170	20	175	14×20×13.1			14,100	34,800	9,900	100

1N≐0.102kgf



PACIFIC INTERNATIONAL BEARING SALES, INC.
800.228.8895 • WWW.PACIFICBEARINGSALES.COM

SMT TYPE

– Two Side Cut Flange Type –

This type is a metric dimension series widely used in Japan and other countries.

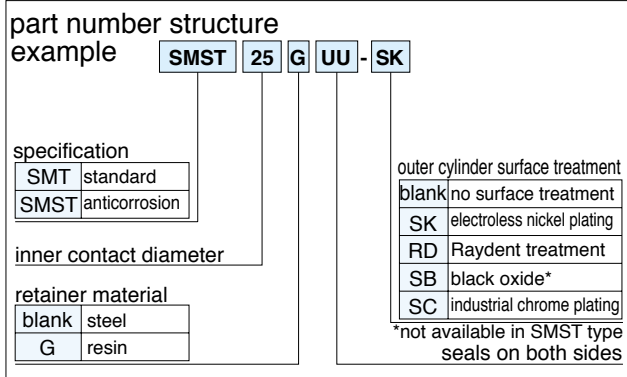

part number*				dr		D		L
standard		anticorrosion		mm	tolerance μm	mm	tolerance μm	±0.3 mm
steel retainer	resin retainer	stainless retainer	resin retainer					
SMT 6UU	SMT 6GUU	SMST 6UU	SMST 6GUU	6	0 - 9	12	0	19
SMT 8UU	SMT 8GUU	SMST 8UU	SMST 8GUU	8		15	-13	24
SMT10UU	SMT10GUU	SMST10UU	SMST10GUU	10		19	0	29
SMT12UU	SMT12GUU	SMST12UU	SMST12GUU	12		21	0	30
SMT13UU	SMT13GUU	SMST13UU	SMST13GUU	13		23	-16	32
SMT16UU	SMT16GUU	SMST16UU	SMST16GUU	16		28	-16	37
SMT20UU	SMT20GUU	SMST20UU	SMST20GUU	20	0 -10	32	0	42
SMT25UU	SMT25GUU	SMST25UU	SMST25GUU	25		40	0	59
SMT30UU	SMT30GUU	SMST30UU	SMST30GUU	30		45	-19	64

* UU type is standard feature.



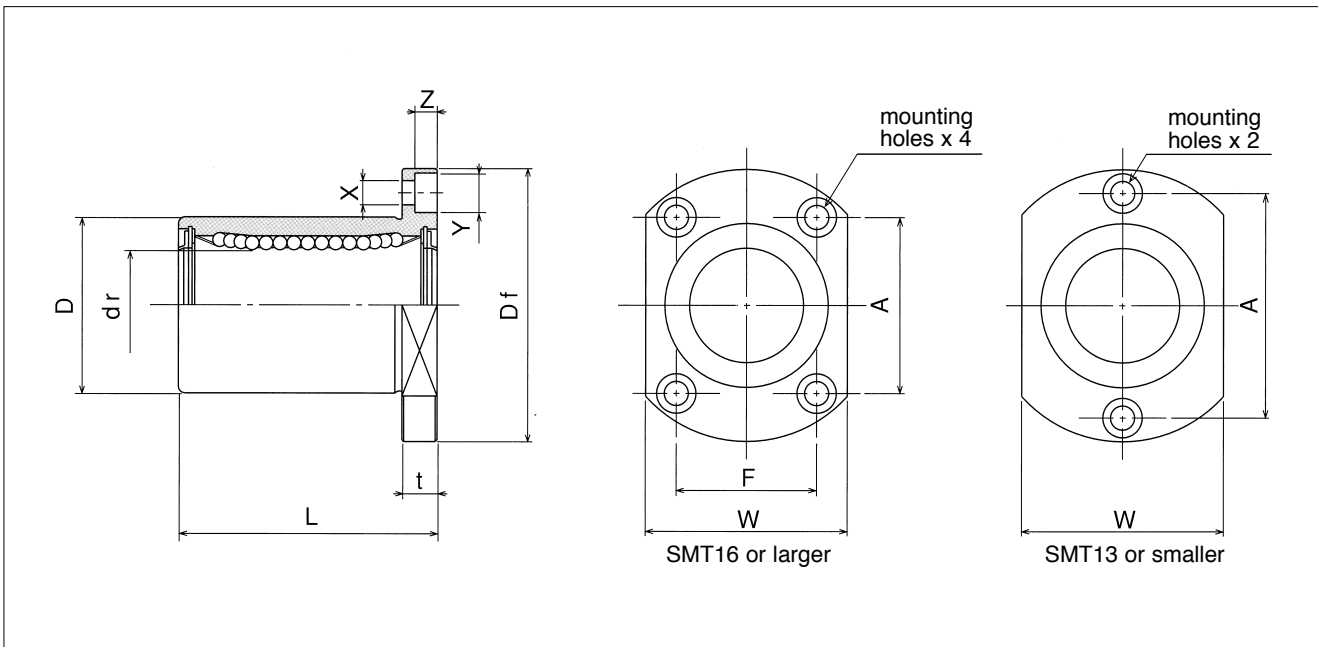

major dimensions						eccentricity	perpen- dicularity	basic load rating		mass	shaft diameter
flange								dynamic	static		
Df	W	t	A	F	X×Y×Z	μm	μm			C	Co
mm	mm	mm	mm	mm	mm			N	N		
28	18	5	20	—	3.5×6×3.1	12	12	206	265	21	6
32	21	5	24	—	3.5×6×3.1			274	392	33	8
40	25	6	29	—	4.5×7.5×4.1			372	549	64	10
42	27	6	32	—	4.5×7.5×4.1			510	784	68	12
43	29	6	33	—	4.5×7.5×4.1			510	784	81	13
48	34	6	31	22	4.5×7.5×4.1			774	1,180	112	16
54	38	8	36	24	5.5×9×5.1	15	15	882	1,370	167	20
62	46	8	40	32	5.5×9×5.1			980	1,570	325	25
74	51	10	49	35	6.6×11×6.1			1,570	2,740	388	30

1N≒0.102kgf



PACIFIC INTERNATIONAL BEARING SALES, INC.
800.228.8895 • WWW.PACIFICBEARINGSALES.COM

SMF-E TYPE

– Round Flange Type with Pilot End –

This type is a metric dimension series widely used in Japan and other countries.

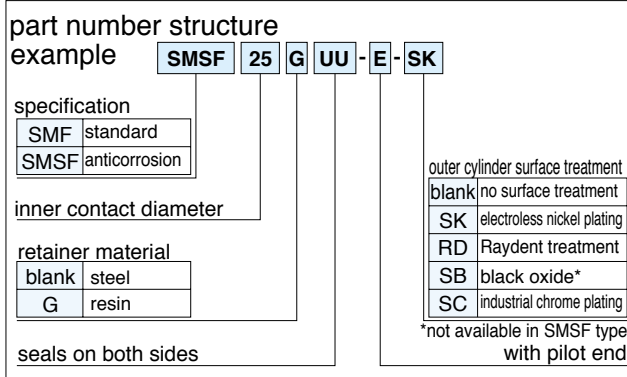

part number*								
standard		anticorrosion		dr		D		L
steel retainer	resin retainer	stainless retainer	resin retainer	mm	tolerance μm	mm	tolerance μm	±0.3 mm
SMF 6UU-E	SMF 6GUU-E	SMSF 6UU-E	SMSF 6GUU-E	6		12	0	19
SMF 8UU-E	SMF 8GUU-E	SMSF 8UU-E	SMSF 8GUU-E	8		15	-13	24
SMF10UU-E	SMF10GUU-E	SMSF10UU-E	SMSF10GUU-E	10	0	19		29
SMF12UU-E	SMF12GUU-E	SMSF12UU-E	SMSF12GUU-E	12	-9	21	0	30
SMF13UU-E	SMF13GUU-E	SMSF13UU-E	SMSF13GUU-E	13		23	-16	32
SMF16UU-E	SMF16GUU-E	SMSF16UU-E	SMSF16GUU-E	16		28		37
SMF20UU-E	SMF20GUU-E	SMSF20UU-E	SMSF20GUU-E	20	0	32	0	42
SMF25UU-E	SMF25GUU-E	SMSF25UU-E	SMSF25GUU-E	25	-10	40	-19	59
SMF30UU-E	SMF30GUU-E	SMSF30UU-E	SMSF30GUU-E	30		45		64
SMF35UU-E	SMF35GUU-E	—	—	35	0	52	0	70
SMF40UU-E	SMF40GUU-E	—	—	40	-12	60	-22	80
SMF50UU-E	SMF50GUU-E	—	—	50		80		100
SMF60UU-E	SMF60GUU-E	—	—	60	0/-15	90	0/-25	110

* UU type is standard feature.



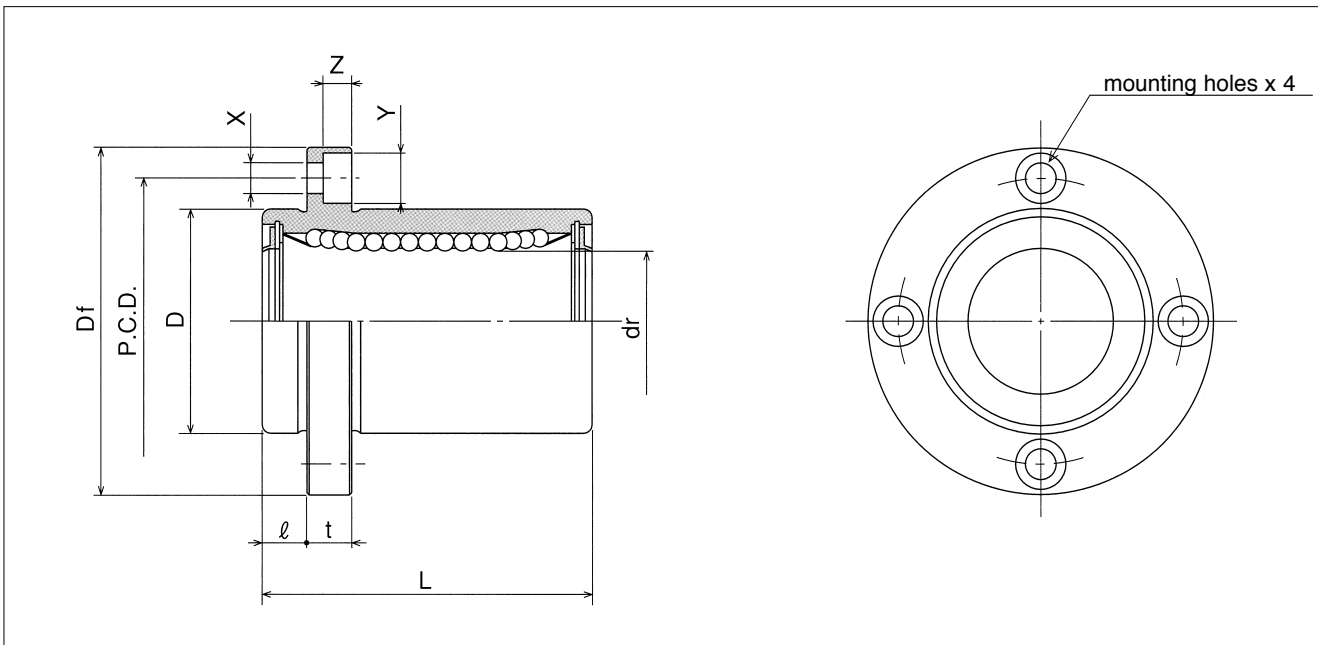

major dimensions					eccentricity	perpendicularity	basic load rating		mass	shaft diameter
flange							dynamic	static		
ℓ mm	Df mm	t mm	P.C.D. mm	X×Y×Z mm	μm	μm	C N	Co N	g	mm
5	28	5	20	3.5×6×3.1	12	12	206	265	24	6
5	32	5	24	3.5×6×3.1			274	392	37	8
6	40	6	29	4.5×7.5×4.1			372	549	72	10
6	42	6	32	4.5×7.5×4.1			510	784	76	12
6	43	6	33	4.5×7.5×4.1			510	784	88	13
6	48	6	38	4.5×7.5×4.1			774	1,180	120	16
8	54	8	43	5.5×9×5.1	15	15	882	1,370	180	20
8	62	8	51	5.5×9×5.1			980	1,570	340	25
10	74	10	60	6.6×11×6.1			1,570	2,740	470	30
10	82	10	67	6.6×11×6.1	20	20	1,670	3,140	650	35
13	96	13	78	9×14×8.1			2,160	4,020	1,060	40
13	116	13	98	9×14×8.1			3,820	7,940	2,200	50
18	134	18	112	11×17×11.1			4,700	10,000	3,000	60

1N \approx 0.102kgf



PACIFIC INTERNATIONAL BEARING SALES, INC.
800.228.8895 • WWW.PACIFICBEARINGSALES.COM

SMK-E TYPE

– Square Flange Type with Pilot End –

This type is a metric dimension series widely used in Japan and other countries.



part number structure	
example	SMSK 25 G UU - E - SK
specification	
SMK	standard
SMSK	anticorrosion
inner contact diameter	
retainer material	
blank	steel
G	resin
seals on both sides	
outer cylinder surface treatment	
blank	no surface treatment
SK	electroless nickel plating
RD	Raydent treatment
SB	black oxide*
SC	industrial chrome plating
*not available in SMSK type with pilot end	

part number*								
standard		anticorrosion		dr		D		L
steel retainer	resin retainer	stainless retainer	resin retainer	mm	tolerance μm	mm	tolerance μm	±0.3 mm
SMK 6UU-E	SMK 6GUU-E	SMSK 6UU-E	SMSK 6GUU-E	6		12	0	19
SMK 8UU-E	SMK 8GUU-E	SMSK 8UU-E	SMSK 8GUU-E	8		15	-13	24
SMK10UU-E	SMK10GUU-E	SMSK10UU-E	SMSK10GUU-E	10	0	19		29
SMK12UU-E	SMK12GUU-E	SMSK12UU-E	SMSK12GUU-E	12	-9	21	0	30
SMK13UU-E	SMK13GUU-E	SMSK13UU-E	SMSK13GUU-E	13		23	-16	32
SMK16UU-E	SMK16GUU-E	SMSK16UU-E	SMSK16GUU-E	16		28		37
SMK20UU-E	SMK20GUU-E	SMSK20UU-E	SMSK20GUU-E	20	0	32	0	42
SMK25UU-E	SMK25GUU-E	SMSK25UU-E	SMSK25GUU-E	25	-10	40	-19	59
SMK30UU-E	SMK30GUU-E	SMSK30UU-E	SMSK30GUU-E	30		45		64
SMK35UU-E	SMK35GUU-E	—	—	35	0	52	0	70
SMK40UU-E	SMK40GUU-E	—	—	40		60		80
SMK50UU-E	SMK50GUU-E	—	—	50	-12	80	-22	100
SMK60UU-E	SMK60GUU-E	—	—	60	0/-15	90	0/-25	110

* UU type is standard feature.



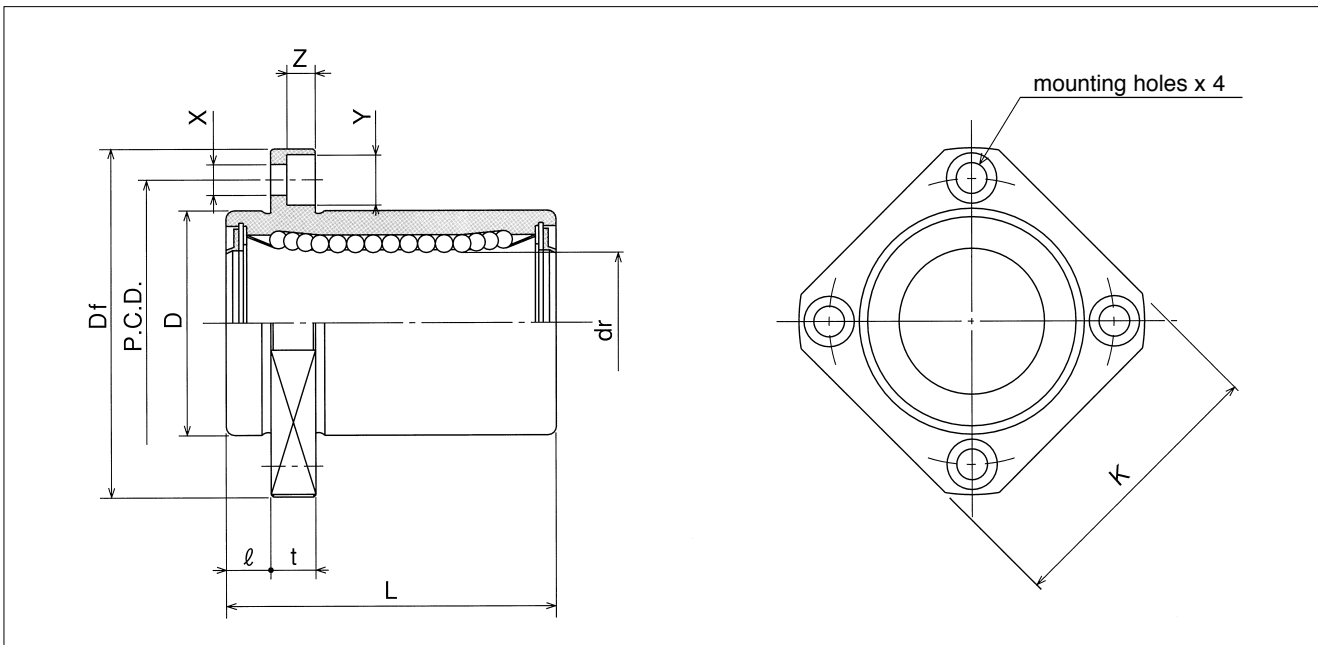

major dimensions						eccentricity μm	perpen- dicularity μm	basic load rating		mass g	shaft diameter mm
flange								dynamic C N	static Co N		
\varnothing mm	D_f mm	K mm	t mm	P.C.D. mm	X×Y×Z mm						
5	28	22	5	20	3.5×6×3.1	12	12	206	265	18	6
5	32	25	5	24	3.5×6×3.1			274	392	29	8
6	40	30	6	29	4.5×7.5×4.1			372	549	52	10
6	42	32	6	32	4.5×7.5×4.1			510	784	57	12
6	43	34	6	33	4.5×7.5×4.1			510	784	72	13
6	48	37	6	38	4.5×7.5×4.1			774	1,180	104	16
8	54	42	8	43	5.5×9×5.1	15	15	882	1,370	145	20
8	62	50	8	51	5.5×9×5.1			980	1,570	300	25
10	74	58	10	60	6.6×11×6.1			1,570	2,740	375	30
10	82	64	10	67	6.6×11×6.1	20	20	1,670	3,140	560	35
13	96	75	13	78	9×14×8.1			2,160	4,020	880	40
13	116	92	13	98	9×14×8.1			3,820	7,940	2,000	50
18	134	106	18	112	11×17×11.1	25	25	4,700	10,000	2,560	60

1N \approx 0.102kgf



PACIFIC INTERNATIONAL BEARING SALES, INC.
800.228.8895 • WWW.PACIFICBEARINGSALES.COM

SMT-E TYPE

– Two Side Cut Pilot End Flange Type –

This type is a metric dimension series widely used in Japan and other countries.

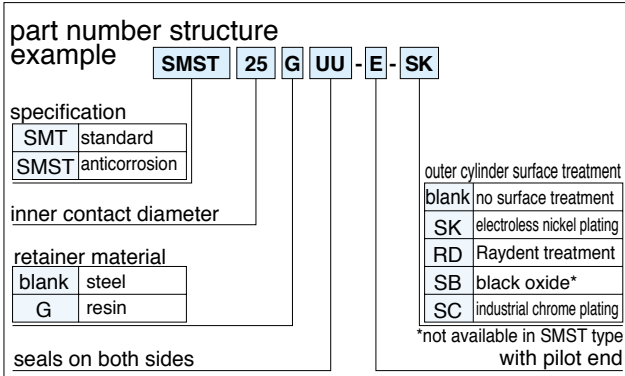

part number*									
standard		anticorrosion		dr		D		L	
steel retainer	resin retainer	stainless retainer	resin retainer	mm	tolerance μm	mm	tolerance μm	±0.3 mm	ℓ mm
SMT 6UU-E	SMT 6GUU-E	SMST 6UU-E	SMST 6GUU-E	6	0 - 9	12	0	19	5
SMT 8UU-E	SMT 8GUU-E	SMST 8UU-E	SMST 8GUU-E	8		15	-13	24	5
SMT10UU-E	SMT10GUU-E	SMST10UU-E	SMST10GUU-E	10		19	0 -16	29	6
SMT12UU-E	SMT12GUU-E	SMST12UU-E	SMST12GUU-E	12		21		30	6
SMT13UU-E	SMT13GUU-E	SMST13UU-E	SMST13GUU-E	13		23		32	6
SMT16UU-E	SMT16GUU-E	SMST16UU-E	SMST16GUU-E	16		28		37	6
SMT20UU-E	SMT20GUU-E	SMST20UU-E	SMST20GUU-E	20	0 -10	32	0 -19	42	8
SMT25UU-E	SMT25GUU-E	SMST25UU-E	SMST25GUU-E	25		40		59	8
SMT30UU-E	SMT30GUU-E	SMST30UU-E	SMST30GUU-E	30		45		64	10

* UU type is standard feature.



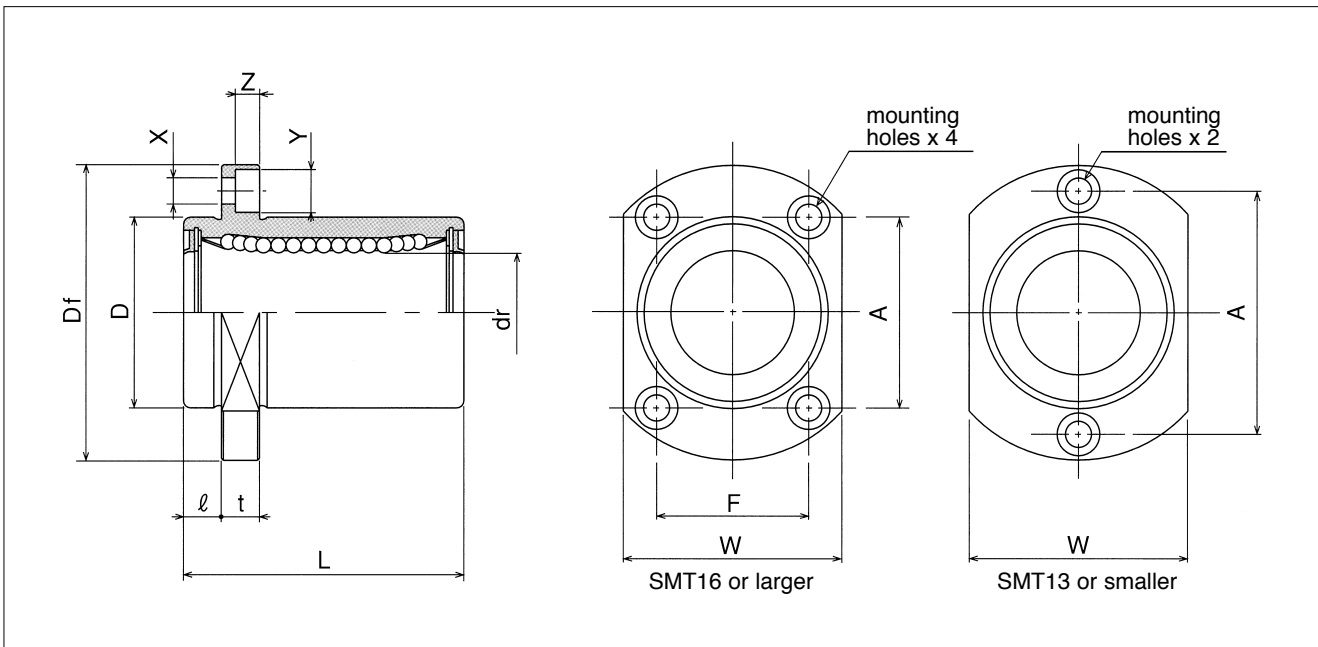

major dimensions						eccentricity μm	perpen- dicularity μm	basic load rating		mass g	shaft diameter mm
flange								dynamic C N	static Co N		
Df mm	W mm	t mm	A mm	F mm	X×Y×Z mm						
28	18	5	20	—	3.5×6×3.1	12	12	206	265	21	6
32	21	5	24	—	3.5×6×3.1			274	392	33	8
40	25	6	29	—	4.5×7.5×4.1			372	549	64	10
42	27	6	32	—	4.5×7.5×4.1			510	784	68	12
43	29	6	33	—	4.5×7.5×4.1			510	784	81	13
48	34	6	31	22	4.5×7.5×4.1			774	1,180	112	16
54	38	8	36	24	5.5×9×5.1	15	15	882	1,370	167	20
62	46	8	40	32	5.5×9×5.1			980	1,570	325	25
74	51	10	49	35	6.6×11×6.1			1,570	2,740	388	30

1N≐0.102kgf



PACIFIC INTERNATIONAL BEARING SALES, INC.
800.228.8895 • WWW.PACIFICBEARINGSALES.COM

SMF-W TYPE

— Round Flange Double-Wide Type —

This type is a metric dimension series widely used in Japan and other countries.

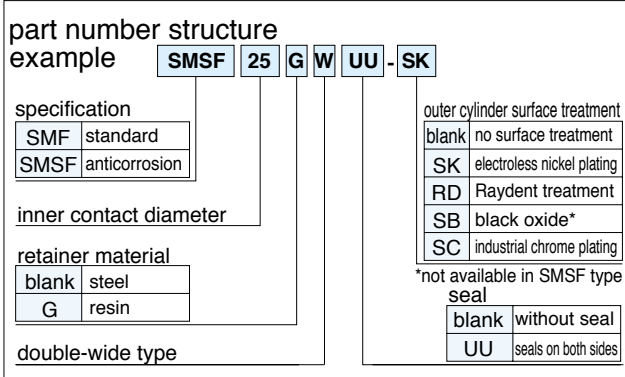
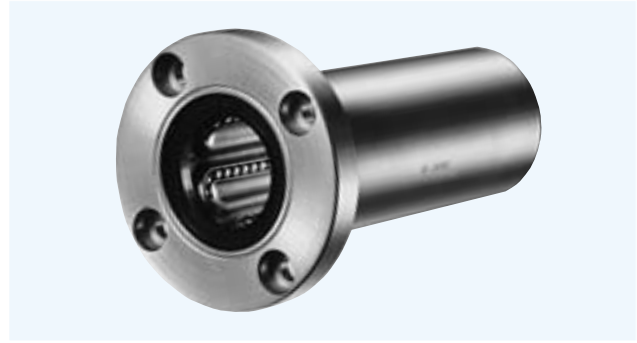

part number				dr		D		L
standard		anticorrosion		mm	tolerance μm	mm	tolerance μm	±0.3 mm
steel retainer	resin retainer	stainless retainer	resin retainer					
SMF 6W	SMF 6GW	SMSF 6W	SMSF 6GW	6	0	12	0	35
SMF 8W	SMF 8GW	SMSF 8W	SMSF 8GW	8		15	-13	45
SMF10W	SMF10GW	SMSF10W	SMSF10GW	10		19	0	55
SMF12W	SMF12GW	SMSF12W	SMSF12GW	12		21		61
SMF13W	SMF13GW	SMSF13W	SMSF13GW	13		23		70
SMF16W	SMF16GW	SMSF16W	SMSF16GW	16		28	-16	80
SMF20W	SMF20GW	SMSF20W	SMSF20GW	20	32	0		112
SMF25W	SMF25GW	SMSF25W	SMSF25GW	25	-12	40	-19	123
SMF30W	SMF30GW	SMSF30W	SMSF30GW	30		45		135
SMF35W	SMF35GW	SMSF35W	SMSF35GW	35	0	52	0	151
SMF40W	SMF40GW	SMSF40W	SMSF40GW	40		60		192
SMF50W	SMF50GW	SMSF50W	SMSF50GW	50		80		-22
SMF60W	SMF60GW	SMSF60W	SMSF60GW	60	0/-20	90	0/-25	



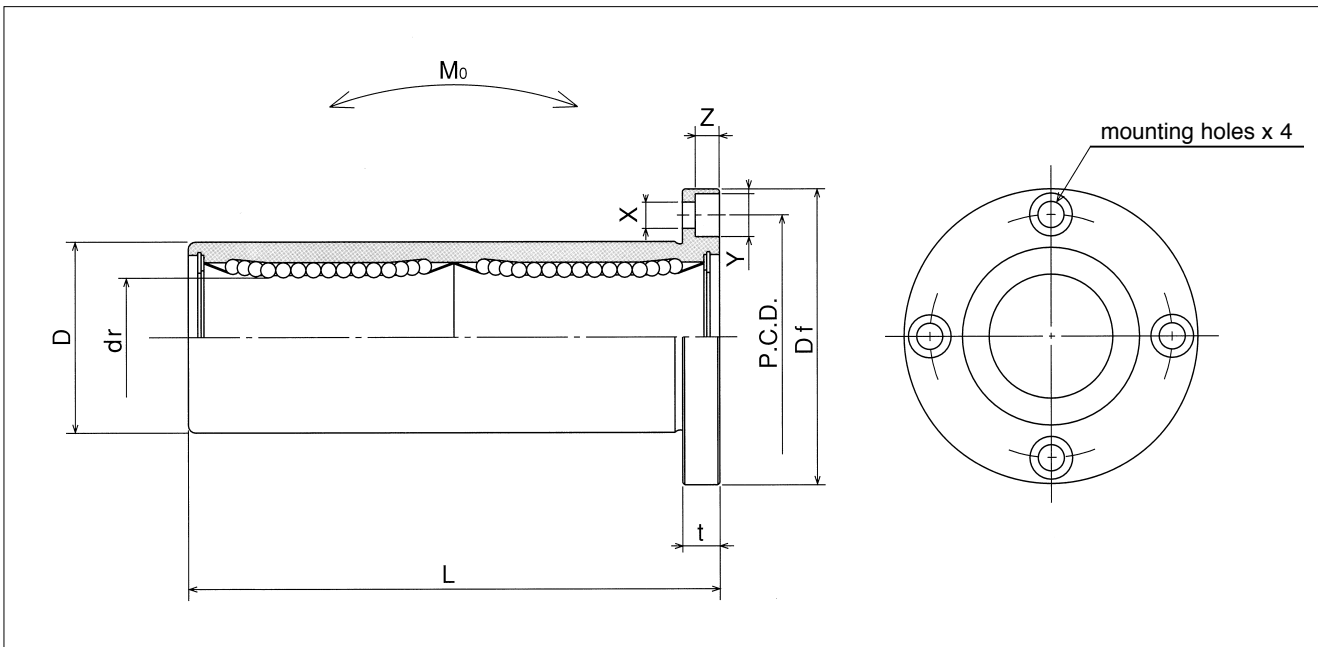

major dimensions				eccentricity	perpendicularity	basic load rating		allowable static moment	mass	shaft diameter
flange						dynamic	static			
D_f mm	t mm	P.C.D. mm	$X \times Y \times Z$ mm	μm	μm	C N	C_o N	M_o N · m	g	mm
28	5	20	3.5 × 6 × 3.1	15	15	323	530	2.18	31	6
32	5	24	3.5 × 6 × 3.1			431	784	4.31	51	8
40	6	29	4.5 × 7.5 × 4.1			588	1,100	7.24	98	10
42	6	32	4.5 × 7.5 × 4.1			813	1,570	10.9	110	12
43	6	33	4.5 × 7.5 × 4.1			813	1,570	11.6	130	13
48	6	38	4.5 × 7.5 × 4.1			1,230	2,350	19.7	190	16
54	8	43	5.5 × 9 × 5.1	20	20	1,400	2,740	26.8	260	20
62	8	51	5.5 × 9 × 5.1			1,560	3,140	43.4	540	25
74	10	60	6.6 × 11 × 6.1			2,490	5,490	82.8	680	30
82	10	67	6.6 × 11 × 6.1	25	25	2,650	6,270	110	1,020	35
96	13	78	9 × 14 × 8.1			3,430	8,040	147	1,570	40
116	13	98	9 × 14 × 8.1			6,080	15,900	397	3,600	50
134	18	112	11 × 17 × 11.1	30	30	7,550	20,000	530	4,500	60

1N ≅ 0.102kgf 1N·m ≅ 0.102kgf·m



PACIFIC INTERNATIONAL BEARING SALES, INC.
800.228.8895 • WWW.PACIFICBEARINGSALES.COM

SMK-W TYPE

— Square Flange Double-Wide Type —

This type is a metric dimension series widely used in Japan and other countries.

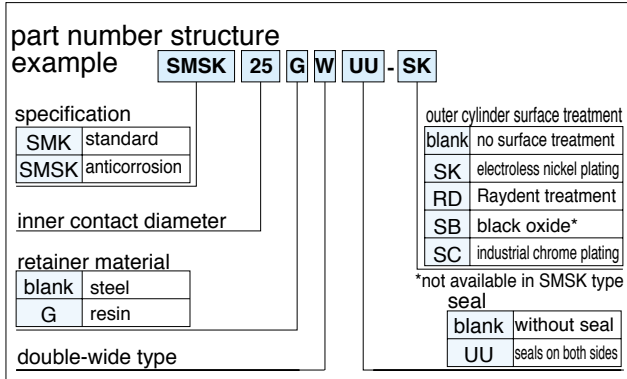
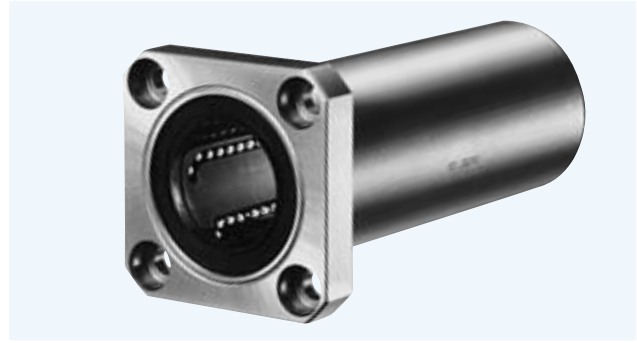

part number									
standard		anticorrosion		dr		D		L	Df
steel retainer	resin retainer	stainless retainer	resin retainer	mm	tolerance μm	mm	tolerance μm	±0.3 mm	mm
SMK 6W	SMK 6GW	SMSK 6W	SMSK 6GW	6	-10	12	0	35	28
SMK 8W	SMK 8GW	SMSK 8W	SMSK 8GW	8		15	-13	45	32
SMK10W	SMK10GW	SMSK10W	SMSK10GW	10		19	0	55	40
SMK12W	SMK12GW	SMSK12W	SMSK12GW	12		21		57	42
SMK13W	SMK13GW	SMSK13W	SMSK13GW	13	-16	23	61	43	
SMK16W	SMK16GW	SMSK16W	SMSK16GW	16		28	70	48	
SMK20W	SMK20GW	SMSK20W	SMSK20GW	20	0	32	80	54	
SMK25W	SMK25GW	SMSK25W	SMSK25GW	25		40	0	112	62
SMK30W	SMK30GW	SMSK30W	SMSK30GW	30	-12	45	-19	123	74
SMK35W	SMK35GW	SMSK35W	SMSK35GW	35		52	0	135	82
SMK40W	SMK40GW	SMSK40W	SMSK40GW	40	0	60	151	96	
SMK50W	SMK50GW	SMSK50W	SMSK50GW	50		80	-22	192	116
SMK60W	SMK60GW	SMSK60W	SMSK60GW	60	0/-20	90	0/-25	209	134



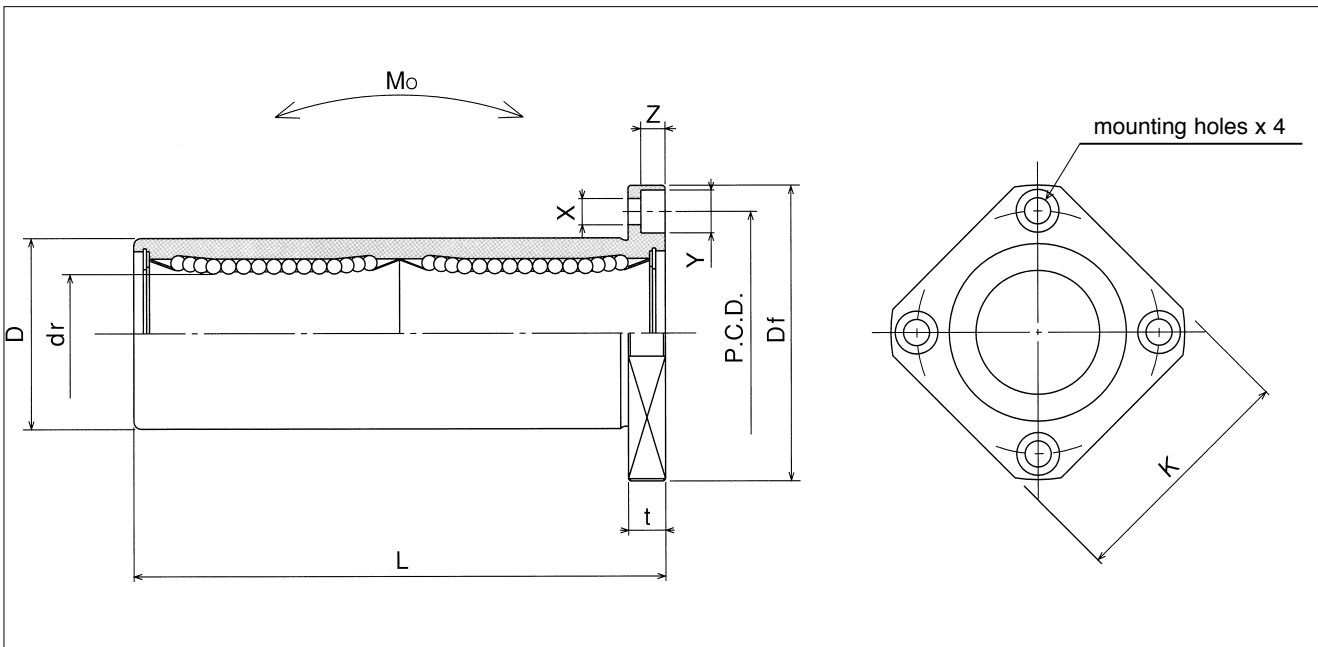

major dimensions				eccentricity μm	perpen- dicularity μm	basic load rating		allowable static moment M_o $\text{N}\cdot\text{m}$	mass g	shaft diameter mm
flange						dynamic C N	static C_o N			
K mm	t mm	P.C.D. mm	$X\times Y\times Z$ mm							
22	5	20	3.5×6×3.1	15	15	323	530	2.18	25	6
25	5	24	3.5×6×3.1			431	784	4.31	43	8
30	6	29	4.5×7.5×4.1			588	1,100	7.24	78	10
32	6	32	4.5×7.5×4.1			813	1,570	10.9	90	12
34	6	33	4.5×7.5×4.1			813	1,570	11.6	108	13
37	6	38	4.5×7.5×4.1			1,230	2,350	19.7	165	16
42	8	43	5.5×9×5.1	20	20	1,400	2,740	26.8	225	20
50	8	51	5.5×9×5.1			1,560	3,140	43.4	500	25
58	10	60	6.6×11×6.1			2,490	5,490	82.8	590	30
64	10	67	6.6×11×6.1	25	25	2,650	6,270	110	930	35
75	13	78	9×14×8.1			3,430	8,040	147	1,380	40
92	13	98	9×14×8.1			6,080	15,900	397	3,400	50
106	18	112	11×17×11.1			7,550	20,000	530	4,060	60

1N \approx 0.102kgf 1N·m \approx 0.102kgf·m



PACIFIC INTERNATIONAL BEARING SALES, INC.
800.228.8895 • WWW.PACIFICBEARINGSALES.COM

SMT-W TYPE

— Two Side Cut Double-Wide Flange Type —

This type is a metric dimension series widely used in Japan and other countries.

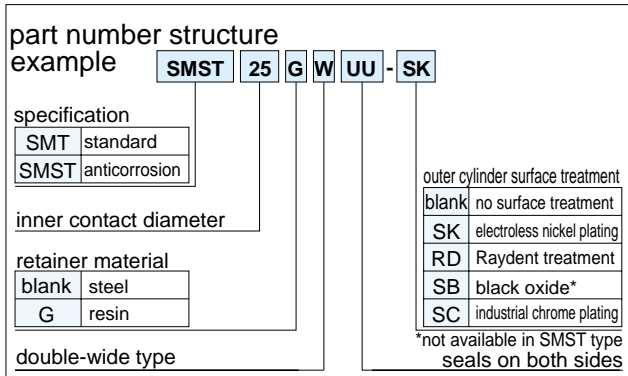

part number*										
standard		anticorrosion		dr		D		L	Df	
steel retainer	resin retainer	stainless retainer	resin retainer	mm	tolerance μm	mm	tolerance μm	±0.3 mm	mm	
SMT 6WUU	SMT 6GWUU	SMST 6WUU	SMST 6GWUU	6	-10	12	0	35	28	
SMT 8WUU	SMT 8GWUU	SMST 8WUU	SMST 8GWUU	8		15	-13	45	32	
SMT10WUU	SMT10GWUU	SMST10WUU	SMST10GWUU	10		19	-16	55	40	
SMT12WUU	SMT12GWUU	SMST12WUU	SMST12GWUU	12		21		0	57	42
SMT13WUU	SMT13GWUU	SMST13WUU	SMST13GWUU	13		23		61	43	
SMT16WUU	SMT16GWUU	SMST16WUU	SMST16GWUU	16		28		70	48	
SMT20WUU	SMT20GWUU	SMST20WUU	SMST20GWUU	20	-12	32	-19	80	54	
SMT25WUU	SMT25GWUU	SMST25WUU	SMST25GWUU	25		40		0	112	62
SMT30WUU	SMT30GWUU	SMST30WUU	SMST30GWUU	30		45		123	74	

* UU type is standard feature.

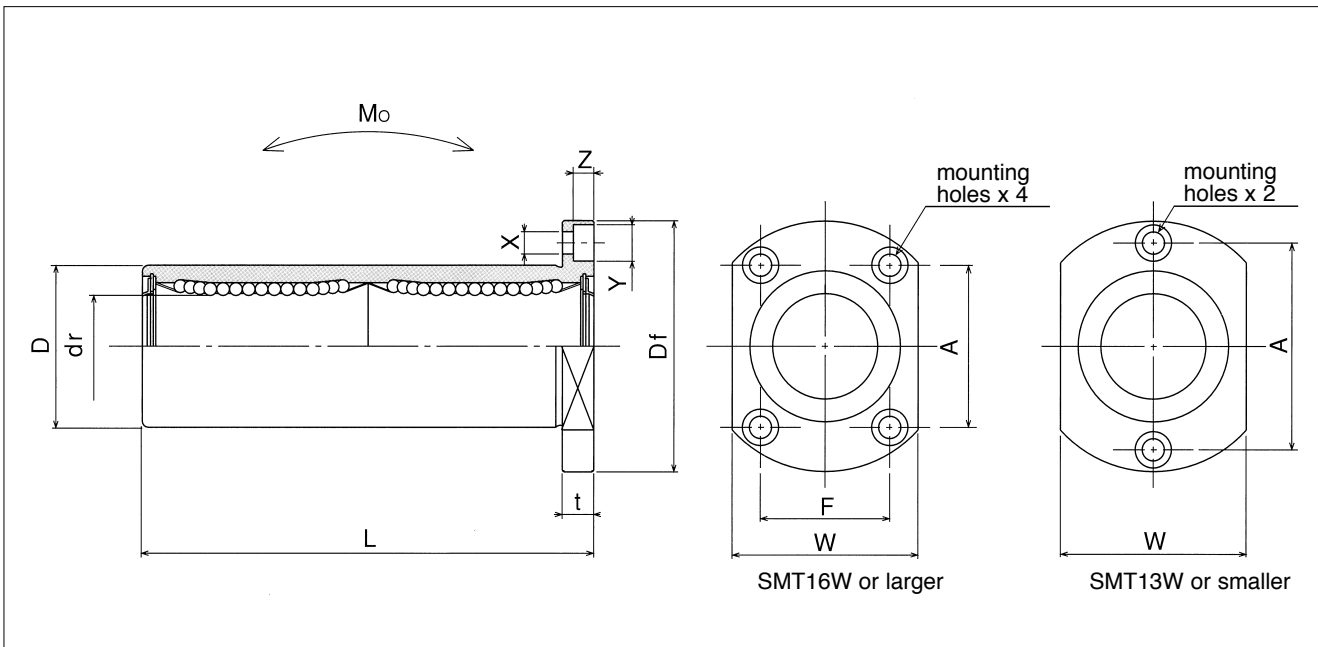

major dimensions					eccentricity	perpen- dicularity	basic load rating		allowable static moment	mass	shaft diameter
flange							dynamic	static			
W mm	t mm	A mm	F mm	X×Y×Z mm	μ m	μ m			C N	Co N	Mo N·m
18	5	20	—	3.5×6×3.1	15	15	323	530	2.18	28	6
21	5	24	—	3.5×6×3.1			431	784	4.31	47	8
25	6	29	—	4.5×7.5×4.1			588	1,100	7.24	90	10
27	6	32	—	4.5×7.5×4.1			813	1,570	10.9	102	12
29	6	33	—	4.5×7.5×4.1			813	1,570	11.6	123	13
34	6	31	22	4.5×7.5×4.1			1,230	2,350	19.7	182	16
38	8	36	24	5.5×9×5.1	20	20	1,400	2,740	26.8	247	20
46	8	40	32	5.5×9×5.1			1,560	3,140	43.4	525	25
51	10	49	35	6.6×11×6.1			2,490	5,490	82.8	645	30

1N≒0.102kgf 1N·m≒0.102kgf·m



PACIFIC INTERNATIONAL BEARING SALES, INC.
800.228.8895 • WWW.PACIFICBEARINGSALES.COM

SMFC TYPE

– Center Mount Round Flange Type –

This type is a metric dimension series widely used in Japan and other countries.

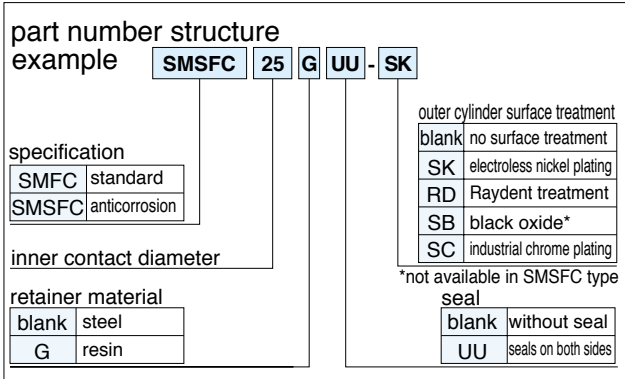

part number									
standard		anticorrosion		dr		D		L	
steel retainer	resin retainer	stainless retainer	resin retainer	mm	tolerance μm	mm	tolerance μm	±0.3 mm	ℓ mm
SMFC 6	SMFC 6G	SMSFC 6	SMSFC 6G	6		12	0	35	15
SMFC 8	SMFC 8G	SMSFC 8	SMSFC 8G	8		15	-13	45	20
SMFC10	SMFC10G	SMSFC10	SMSFC10G	10	0	19		55	24.5
SMFC12	SMFC12G	SMSFC12	SMSFC12G	12	-10	21	0	57	25.5
SMFC13	SMFC13G	SMSFC13	SMSFC13G	13		23	-16	61	27.5
SMFC16	SMFC16G	SMSFC16	SMSFC16G	16		28		70	32
SMFC20	SMFC20G	SMSFC20	SMSFC20G	20	0	32	0	80	36
SMFC25	SMFC25G	SMSFC25	SMSFC25G	25		40	0	112	52
SMFC30	SMFC30G	SMSFC30	SMSFC30G	30	-12	45	-19	123	56.5
SMFC35	SMFC35G	SMSFC35	SMSFC35G	35	0	52	0	135	62.5
SMFC40	SMFC40G	SMSFC40	SMSFC40G	40		60	0	151	69
SMFC50	SMFC50G	SMSFC50	SMSFC50G	50	-15	80	-22	192	89.5
SMFC60	SMFC60G	SMSFC60	SMSFC60G	60	0/-20	90	0/-25	209	95.5



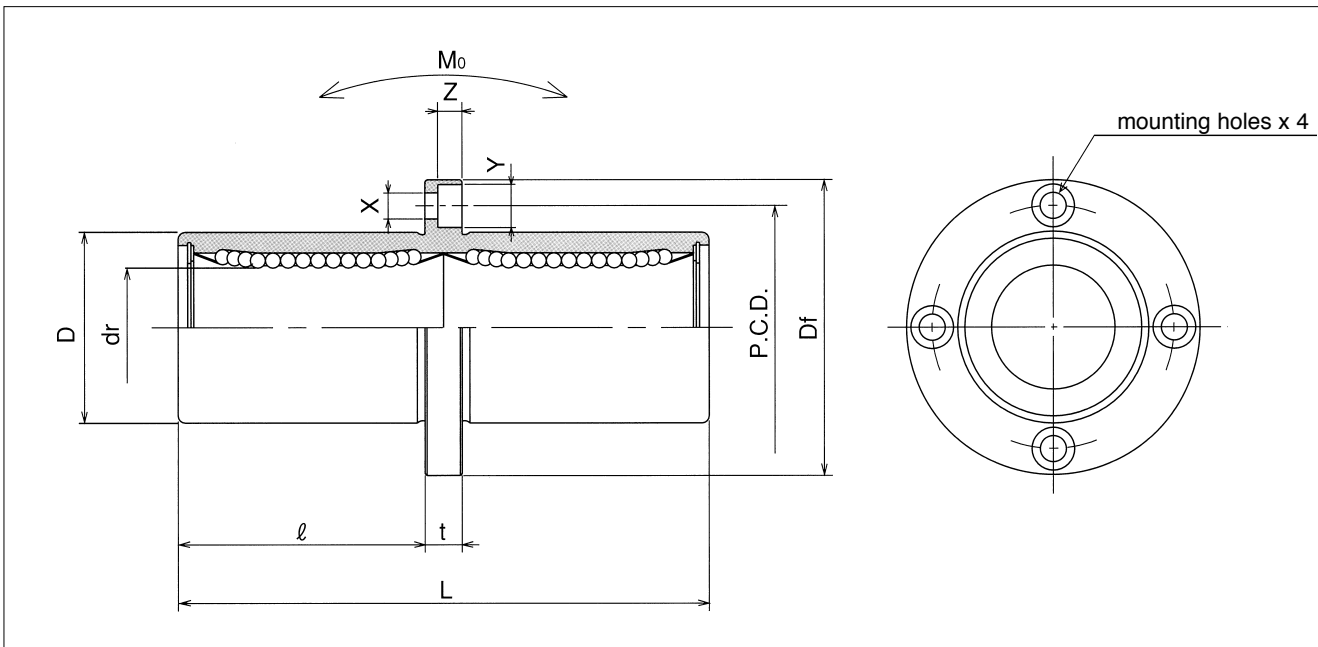

major dimensions				eccentricity μm	perpen- dicularity μm	basic load rating		allowable static moment Mo $\text{N} \cdot \text{m}$	mass g	shaft diameter mm
flange						dynamic C N	static Co N			
Df mm	t mm	P.C.D. mm	X×Y×Z mm							
28	5	20	3.5×6×3.1	15	15	323	530	2.18	31	6
32	5	24	3.5×6×3.1			431	784	4.31	51	8
40	6	29	4.5×7.5×4.1			588	1,100	7.24	98	10
42	6	32	4.5×7.5×4.1			813	1,570	10.9	110	12
43	6	33	4.5×7.5×4.1			813	1,570	11.6	130	13
48	6	38	4.5×7.5×4.1			1,230	2,350	19.7	190	16
54	8	43	5.5×9×5.1	20	20	1,400	2,740	26.8	260	20
62	8	51	5.5×9×5.1			1,560	3,140	43.4	540	25
74	10	60	6.6×11×6.1			2,490	5,490	82.8	680	30
82	10	67	6.6×11×6.1	25	25	2,650	6,270	110	1,020	35
96	13	78	9×14×8.1			3,430	8,040	147	1,570	40
116	13	98	9×14×8.1			6,080	15,900	397	3,600	50
134	18	112	11×17×11.1			7,550	20,000	530	4,500	60

1N \approx 0.102kgf 1N·m \approx 0.102kgf·m

SMKC TYPE

– Center Mount Square Flange Type –

This type is a metric dimension series widely used in Japan and other countries.

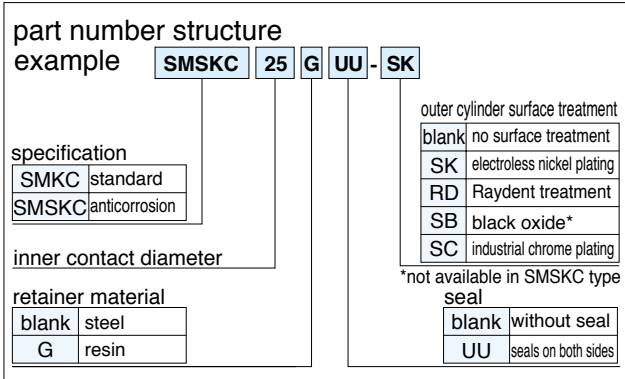

part number				dr		D		L	
standard		anticorrosion		mm	tolerance μm	mm	tolerance μm	±0.3 mm	ℓ mm
steel retainer	resin retainer	stainless retainer	resin retainer						
SMKC 6	SMKC 6G	SMSKC 6	SMSKC 6G	6	0	12	0	35	15
SMKC 8	SMKC 8G	SMSKC 8	SMSKC 8G	8		15	-13	45	20
SMKC10	SMKC10G	SMSKC10	SMSKC10G	10		19	0	55	24.5
SMKC12	SMKC12G	SMSKC12	SMSKC12G	12	-10	21	0	57	25.5
SMKC13	SMKC13G	SMSKC13	SMSKC13G	13		23	-16	61	27.5
SMKC16	SMKC16G	SMSKC16	SMSKC16G	16		28	70	32	
SMKC20	SMKC20G	SMSKC20	SMSKC20G	20	0	32	0	80	36
SMKC25	SMKC25G	SMSKC25	SMSKC25G	25		40	0	112	52
SMKC30	SMKC30G	SMSKC30	SMSKC30G	30		45	-19	123	56.5
SMKC35	SMKC35G	SMSKC35	SMSKC35G	35	0	52	0	135	62.5
SMKC40	SMKC40G	SMSKC40	SMSKC40G	40		60	0	151	69
SMKC50	SMKC50G	SMSKC50	SMSKC50G	50		80	-22	192	89.5
SMKC60	SMKC60G	SMSKC60	SMSKC60G	60	0/-20	90	0/-25	209	95.5



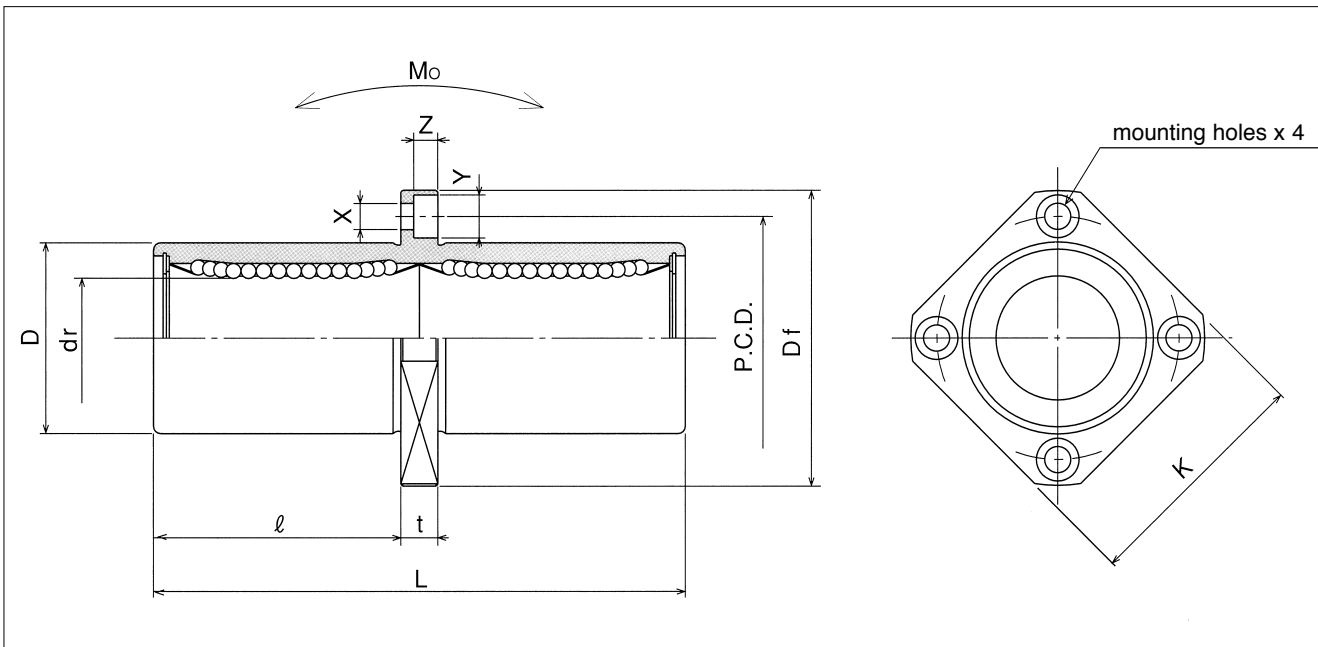

major dimensions					eccentricity	perpendicularity	basic load rating		allowable static moment	mass	shaft diameter
flange							dynamic	static			
Df	K	t	P.C.D.	X×Y×Z	C	Co			Mo	g	mm
mm	mm	mm	mm	mm	μm	μm	N	N	N·m	mm	
28	22	5	20	3.5×6×3.1	15	15	323	530	2.18	25	6
32	25	5	24	3.5×6×3.1			431	784	4.31	43	8
40	30	6	29	4.5×7.5×4.1			588	1,100	7.24	78	10
42	32	6	32	4.5×7.5×4.1			813	1,570	10.9	90	12
43	34	6	33	4.5×7.5×4.1			813	1,570	11.6	108	13
48	37	6	38	4.5×7.5×4.1			1,230	2,350	19.7	165	16
54	42	8	43	5.5×9×5.1	20	20	1,400	2,740	26.8	225	20
62	50	8	51	5.5×9×5.1			1,560	3,140	43.4	500	25
74	58	10	60	6.6×11×6.1			2,490	5,490	82.8	590	30
82	64	10	67	6.6×11×6.1	25	25	2,650	6,270	110	930	35
96	75	13	78	9×14×8.1			3,430	8,040	147	1,380	40
116	92	13	98	9×14×8.1			6,080	15,900	397	3,400	50
134	106	18	112	11×17×11.1	30	30	7,550	20,000	530	4,060	60

1N≐0.102kgf 1N·m≐0.102kgf·m



SMTC TYPE

– Two Side Cut Center Flange Type –

This type is a metric dimension series widely used in Japan and other countries.

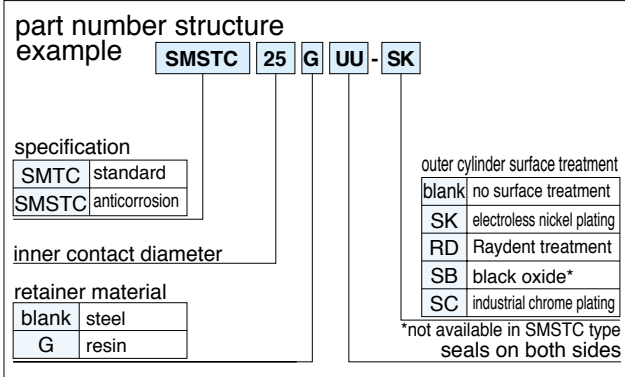

part number*										
standard		anticorrosion		dr		D		L		
steel retainer	resin retainer	stainless retainer	resin retainer	mm	tolerance μm	mm	tolerance μm	±0.3 mm	ℓ mm	Df mm
SMTC 6UU	SMTC 6GUU	SMSTC 6UU	SMSTC 6GUU	6		12	0	35	15	28
SMTC 8UU	SMTC 8GUU	SMSTC 8UU	SMSTC 8GUU	8		15	-13	45	20	32
SMTC10UU	SMTC10GUU	SMSTC10UU	SMSTC10GUU	10	0	19		55	24.5	40
SMTC12UU	SMTC12GUU	SMSTC12UU	SMSTC12GUU	12	-10	21	0	57	25.5	42
SMTC13UU	SMTC13GUU	SMSTC13UU	SMSTC13GUU	13		23	-16	61	27.5	43
SMTC16UU	SMTC16GUU	SMSTC16UU	SMSTC16GUU	16		28		70	32	48
SMTC20UU	SMTC20GUU	SMSTC20UU	SMSTC20GUU	20	0	32	0	80	36	54
SMTC25UU	SMTC25GUU	SMSTC25UU	SMSTC25GUU	25		40		112	52	62
SMTC30UU	SMTC30GUU	SMSTC30UU	SMSTC30GUU	30	-12	45	-19	123	56.5	74

* UU type is standard.



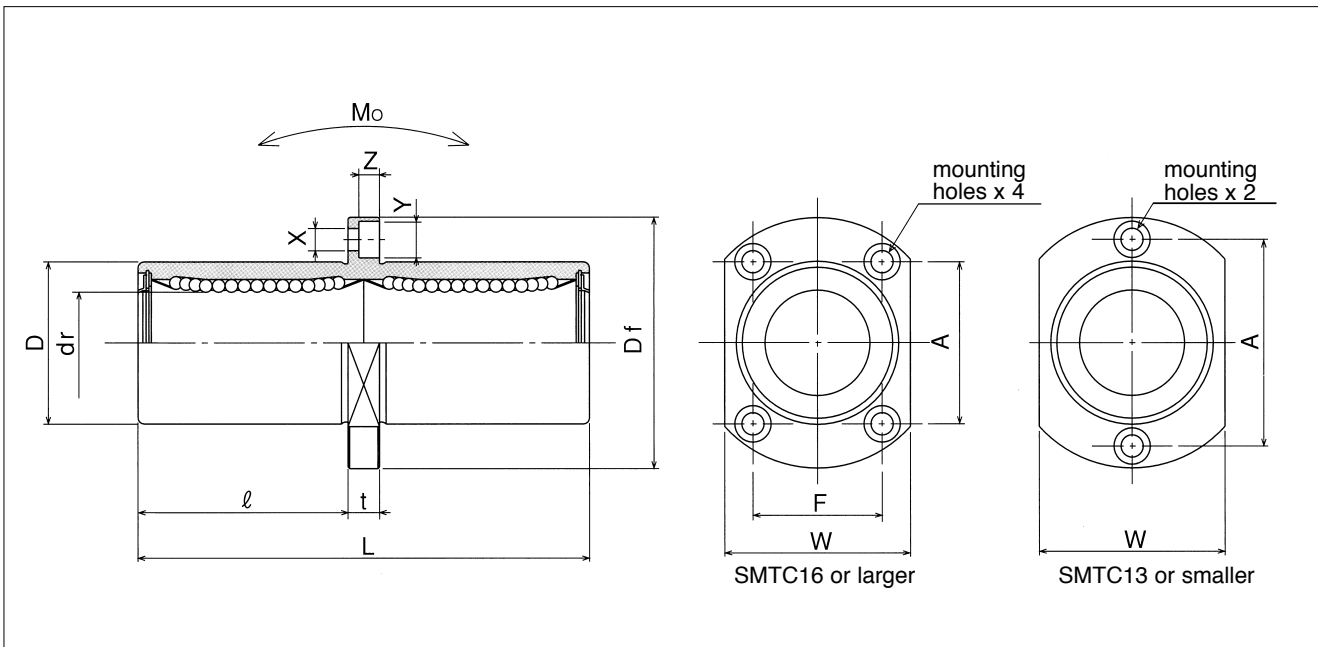

major dimensions					eccentricity μm	perpen- dicularity μm	basic load rating		allowable static moment M_o $\text{N} \cdot \text{m}$	mass g	shaft diameter mm
flange							dynamic C N	static C_o N			
W mm	t mm	A mm	F mm	$X \times Y \times Z$ mm							
18	5	20	—	3.5×6×3.1	15	15	323	530	2.18	28	6
21	5	24	—	3.5×6×3.1			431	784	4.31	47	8
25	6	29	—	4.5×7.5×4.1			588	1,100	7.24	90	10
27	6	32	—	4.5×7.5×4.1			813	1,570	10.9	102	12
29	6	33	—	4.5×7.5×4.1			813	1,570	11.6	123	13
34	6	31	22	4.5×7.5×4.1			1,230	2,350	19.7	182	16
38	8	36	24	5.5×9×5.1	20	20	1,400	2,740	26.8	247	20
46	8	40	32	5.5×9×5.1			1,560	3,140	43.4	525	25
51	10	49	35	6.6×11×6.1			2,490	5,490	82.8	645	30

1N \approx 0.102kgf 1N·m \approx 0.102kgf·m



PACIFIC INTERNATIONAL BEARING SALES, INC.
800.228.8895 • WWW.PACIFICBEARINGSALES.COM

SMF-W-E TYPE

— Round Flange Double-Wide Pilot End Type —

This type is a metric dimension series widely used in Japan and other countries.

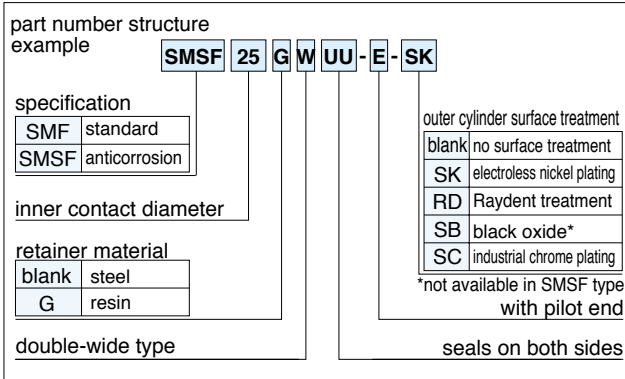

part number*									
standard		anticorrosion		dr		D		L	
steel retainer	resin retainer	stainless retainer	resin retainer	mm	tolerance μm	mm	tolerance μm	±0.3 mm	ℓ mm
SMF 6WUU-E	SMF 6GWUU-E	SMSF 6WUU-E	SMSF 6GWUU-E	6	-10	12	0	35	5
SMF 8WUU-E	SMF 8GWUU-E	SMSF 8WUU-E	SMSF 8GWUU-E	8		15	-13	45	5
SMF10WUU-E	SMF10GWUU-E	SMSF10WUU-E	SMSF10GWUU-E	10		19	0	55	6
SMF12WUU-E	SMF12GWUU-E	SMSF12WUU-E	SMSF12GWUU-E	12		21		57	6
SMF13WUU-E	SMF13GWUU-E	SMSF13WUU-E	SMSF13GWUU-E	13		23	-16	61	6
SMF16WUU-E	SMF16GWUU-E	SMSF16WUU-E	SMSF16GWUU-E	16		28	70	6	
SMF20WUU-E	SMF20GWUU-E	SMSF20WUU-E	SMSF20GWUU-E	20	0	32	0	80	8
SMF25WUU-E	SMF25GWUU-E	SMSF25WUU-E	SMSF25GWUU-E	25		40		112	8
SMF30WUU-E	SMF30GWUU-E	SMSF30WUU-E	SMSF30GWUU-E	30	-12	45	-19	123	10
SMF35WUU-E	SMF35GWUU-E	—	—	35	0	52	0	135	10
SMF40WUU-E	SMF40GWUU-E	—	—	40		60		151	13
SMF50WUU-E	SMF50GWUU-E	—	—	50	-15	80	-22	192	13
SMF60WUU-E	SMF60GWUU-E	—	—	60		0/-20		90	0/-25

* UU type is standard.



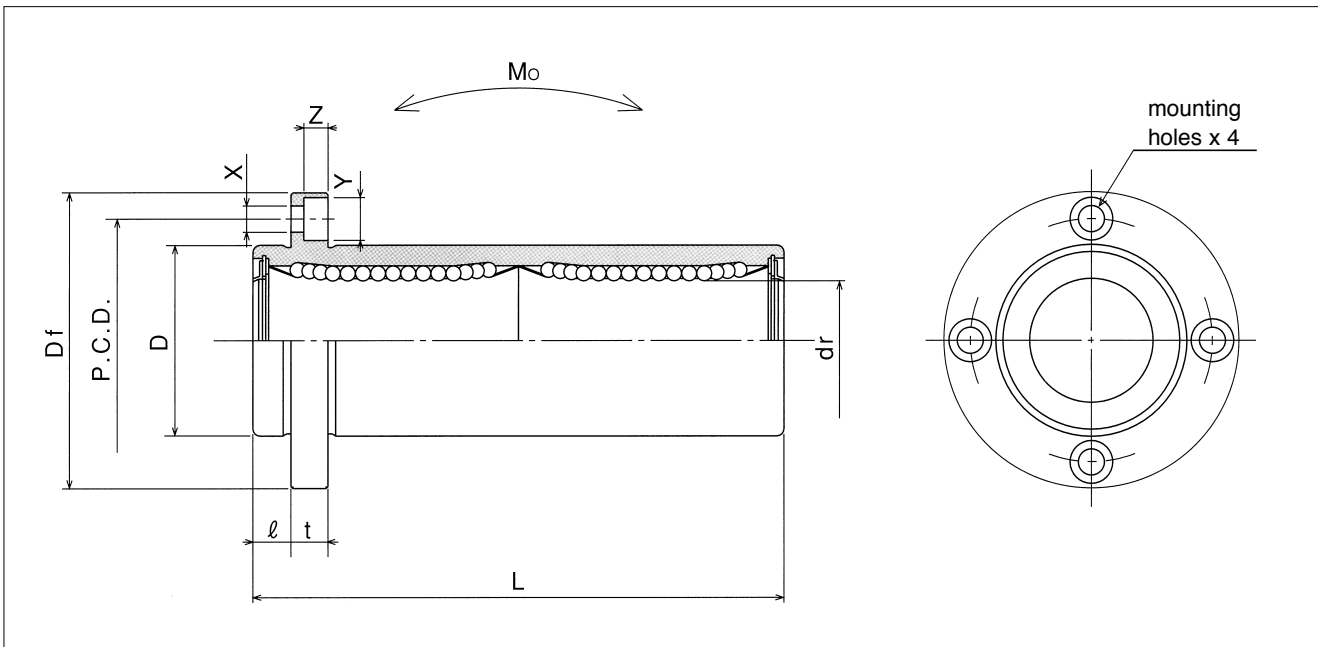

major dimensions				eccentricity	perpendicularity	basic load rating		allowable static moment Mo	mass	shaft diameter
flange						dynamic	static			
Df	t	P.C.D.	X×Y×Z	μm	μm			C	Co	N·m
mm	mm	mm	mm			N	N			
28	5	20	3.5×6×3.1	15	15	323	530	2.18	31	6
32	5	24	3.5×6×3.1			431	784	4.31	51	8
40	6	29	4.5×7.5×4.1			588	1,100	7.24	98	10
42	6	32	4.5×7.5×4.1			813	1,570	10.9	110	12
43	6	33	4.5×7.5×4.1			813	1,570	11.6	130	13
48	6	38	4.5×7.5×4.1			1,230	2,350	19.7	190	16
54	8	43	5.5×9×5.1	20	20	1,400	2,740	26.8	260	20
62	8	51	5.5×9×5.1			1,560	3,140	43.4	540	25
74	10	60	6.6×11×6.1			2,490	5,490	82.8	680	30
82	10	67	6.6×11×6.1	25	25	2,650	6,270	110	1,020	35
96	13	78	9×14×8.1			3,430	8,040	147	1,570	40
116	13	98	9×14×8.1			6,080	15,900	397	3,600	50
134	18	112	11×17×11.1			7,550	20,000	530	4,500	60

1N ≅ 0.102kgf 1N·m ≅ 0.102kgf·m



PACIFIC INTERNATIONAL BEARING SALES, INC.
800.228.8895 • WWW.PACIFICBEARINGSALES.COM

SMK-W-E TYPE

– Square Flange Double-Wide Pilot End Type –

This type is a metric dimension series widely used in Japan and other countries.

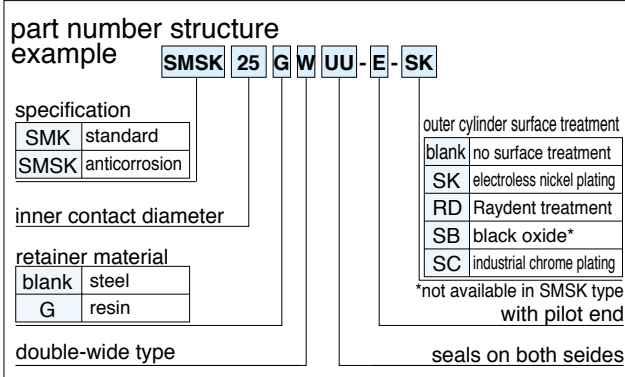

part number*									
standard		anticorrosion		dr		D		L	
steel retainer	resin retainer	stainless retainer	resin retainer	mm	tolerance μm	mm	tolerance μm	±0.3 mm	ℓ mm
SMK 6WUU-E	SMK 6GWUU-E	SMSK 6WUU-E	SMSK 6GWUU-E	6		12	0	35	5
SMK 8WUU-E	SMK 8GWUU-E	SMSK 8WUU-E	SMSK 8GWUU-E	8		15	-13	45	5
SMK10WUU-E	SMK10GWUU-E	SMSK10WUU-E	SMSK10GWUU-E	10	0	19		55	6
SMK12WUU-E	SMK12GWUU-E	SMSK12WUU-E	SMSK12GWUU-E	12	-10	21	0	57	6
SMK13WUU-E	SMK13GWUU-E	SMSK13WUU-E	SMSK13GWUU-E	13		23	-16	61	6
SMK16WUU-E	SMK16GWUU-E	SMSK16WUU-E	SMSK16GWUU-E	16		28		70	6
SMK20WUU-E	SMK20GWUU-E	SMSK20WUU-E	SMSK20GWUU-E	20	0	32	0	80	8
SMK25WUU-E	SMK25GWUU-E	SMSK25WUU-E	SMSK25GWUU-E	25	-12	40	-19	112	8
SMK30WUU-E	SMK30GWUU-E	SMSK30WUU-E	SMSK30GWUU-E	30		45		123	10
SMK35WUU-E	SMK35GWUU-E	—	—	35	0	52	0	135	10
SMK40WUU-E	SMK40GWUU-E	—	—	40	-15	60	-22	151	13
SMK50WUU-E	SMK50GWUU-E	—	—	50		80		192	13
SMK60WUU-E	SMK60GWUU-E	—	—	60	0/-20	90	0/-25	209	18

* UU type is standard.



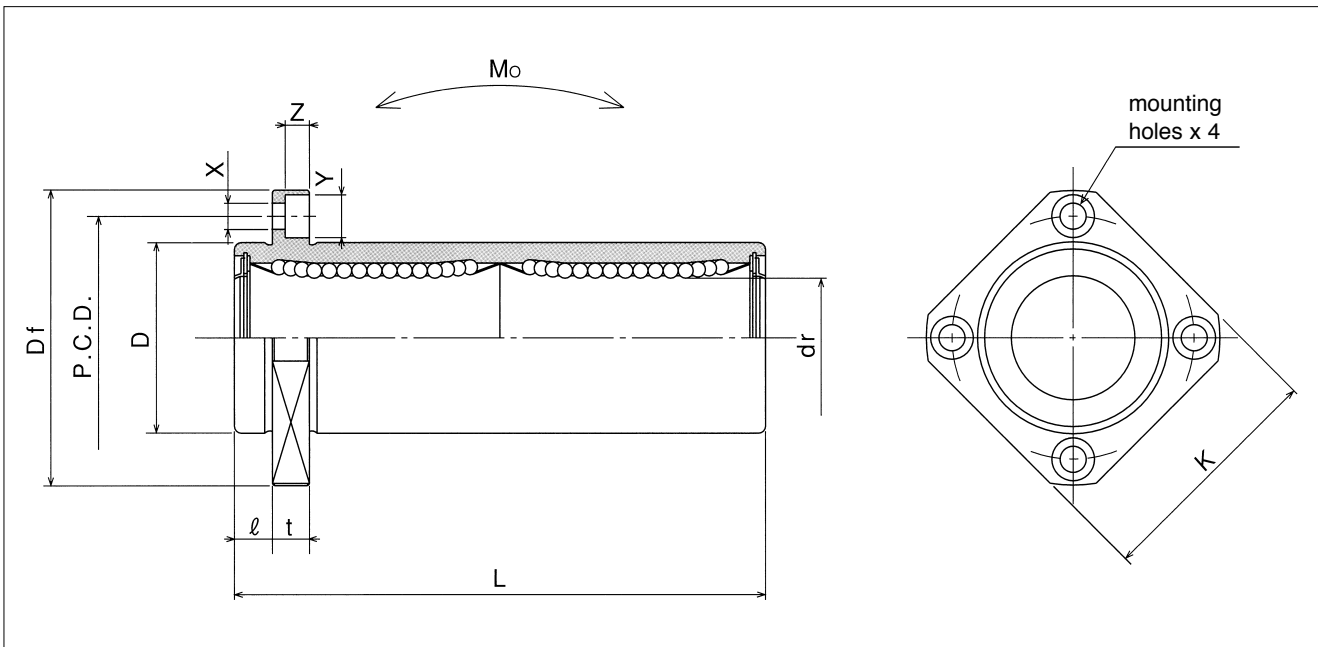

major dimensions					eccentricity	perpendicularity	basic load rating		allowable static moment	mass	shaft diameter
flange							dynamic	static			
Df	K	t	P.C.D.	X×Y×Z	C	Co			Mo	g	mm
mm	mm	mm	mm	mm	μm	μm	N	N	N·m	mm	
28	22	5	20	3.5×6×3.1	15	15	323	530	2.18	25	6
32	25	5	24	3.5×6×3.1			431	784	4.31	43	8
40	30	6	29	4.5×7.5×4.1			588	1,100	7.24	78	10
42	32	6	32	4.5×7.5×4.1			813	1,570	10.9	90	12
43	34	6	33	4.5×7.5×4.1			813	1,570	11.6	108	13
48	37	6	38	4.5×7.5×4.1			1,230	2,350	19.7	165	16
54	42	8	43	5.5×9×5.1	20	20	1,400	2,740	26.8	225	20
62	50	8	51	5.5×9×5.1			1,560	3,140	43.4	500	25
74	58	10	60	6.6×11×6.1			2,490	5,490	82.8	590	30
82	64	10	67	6.6×11×6.1	25	25	2,650	6,270	110	930	35
96	75	13	78	9×14×8.1			3,430	8,040	147	1,380	40
116	92	13	98	9×14×8.1			6,080	15,900	397	3,400	50
134	106	18	112	11×17×11.1	30	30	7,550	20,000	530	4,060	60

1N ≅ 0.102kgf 1N·m ≅ 0.102kgf·m



PACIFIC INTERNATIONAL BEARING SALES, INC.
800.228.8895 • WWW.PACIFICBEARINGSALES.COM

SMT-W-E TYPE

— Two Side Cut Double-Wide Flange Pilot End Type —

This type is a metric dimension series widely used in Japan and other countries.

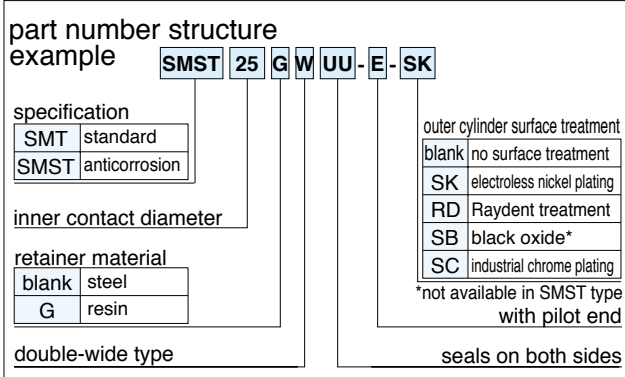
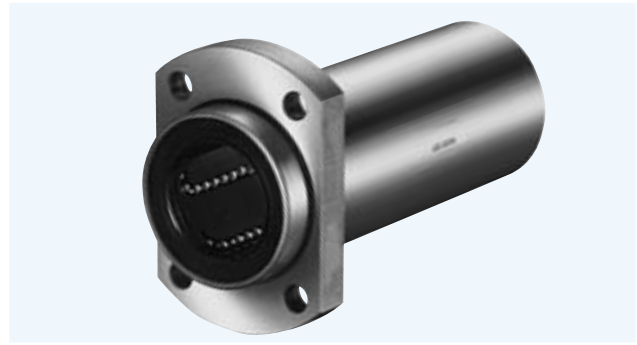

part number*										
standard		anticorrosion		dr		D		L		
steel retainer	resin retainer	stainless retainer	resin retainer	mm	tolerance μm	mm	tolerance μm	±0.3 mm	ℓ mm	Df mm
SMT 6WUU-E	SMT 6GWUU-E	SMST 6WUU-E	SMST 6GWUU-E	6		12	0	35	5	28
SMT 8WUU-E	SMT 8GWUU-E	SMST 8WUU-E	SMST 8GWUU-E	8		15	-13	45	5	32
SMT10WUU-E	SMT10GWUU-E	SMST10WUU-E	SMST10GWUU-E	10	0	19		55	6	40
SMT12WUU-E	SMT12GWUU-E	SMST12WUU-E	SMST12GWUU-E	12	-10	21	0	57	6	42
SMT13WUU-E	SMT13GWUU-E	SMST13WUU-E	SMST13GWUU-E	13		23	-16	61	6	43
SMT16WUU-E	SMT16GWUU-E	SMST16WUU-E	SMST16GWUU-E	16		28		70	6	48
SMT20WUU-E	SMT20GWUU-E	SMST20WUU-E	SMST20GWUU-E	20	0	32	0	80	8	54
SMT25WUU-E	SMT25GWUU-E	SMST25WUU-E	SMST25GWUU-E	25		40		112	8	62
SMT30WUU-E	SMT30GWUU-E	SMST30WUU-E	SMST30GWUU-E	30	-12	45	-19	123	10	74

* UU type is standard feature.



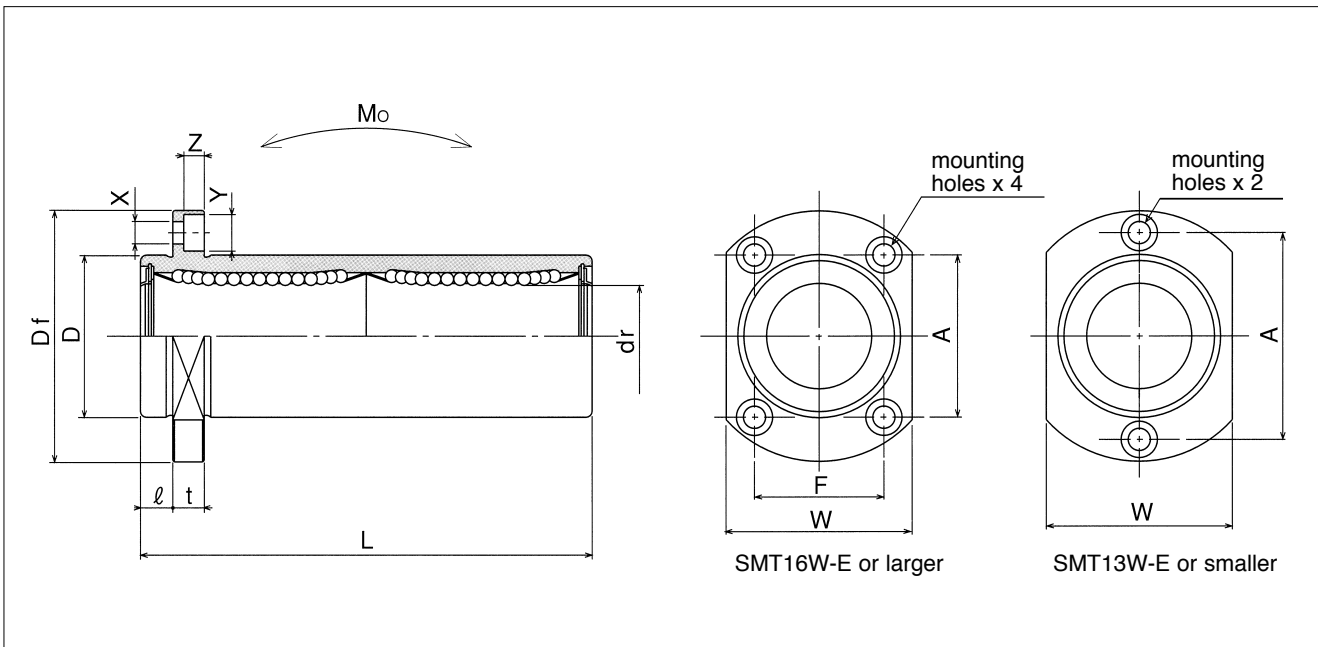

major dimensions					eccentricity	perpen- dicularity	basic load rating		allowable static moment M_o	mass	shaft diameter
flange							dynamic	static			
W mm	t mm	A mm	F mm	X×Y×Z mm	μm	μm			C N	Co N	N·m
18	5	20	—	3.5×6×3.1	15	15	323	530	2.18	28	6
21	5	24	—	3.5×6×3.1			431	784	4.31	47	8
25	6	29	—	4.5×7.5×4.1			588	1,100	7.24	90	10
27	6	32	—	4.5×7.5×4.1			813	1,570	10.9	102	12
29	6	33	—	4.5×7.5×4.1			813	1,570	11.6	123	13
34	6	31	22	4.5×7.5×4.1			1,230	2,350	19.7	182	16
38	8	36	24	5.5×9×5.1	20	20	1,400	2,740	26.8	247	20
46	8	40	32	5.5×9×5.1			1,560	3,140	43.4	525	25
51	10	49	35	6.6×11×6.1			2,490	5,490	82.8	645	30

1N≒0.102kgf 1N·m≒0.102kgf·m



PACIFIC INTERNATIONAL BEARING SALES, INC.
800.228.8895 • WWW.PACIFICBEARINGSales.COM