

SNW TYPE

– NB Inch Shaft –

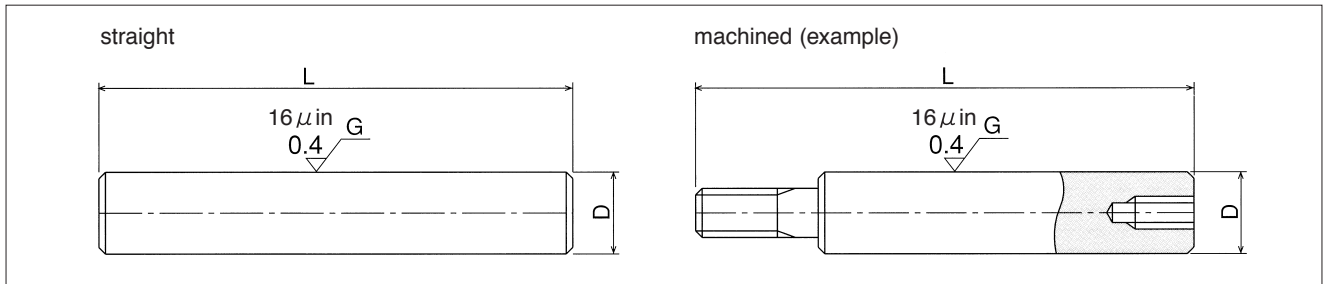
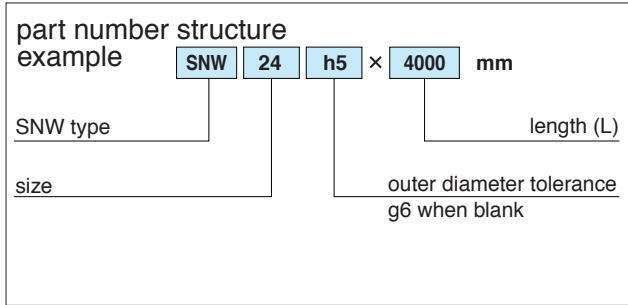
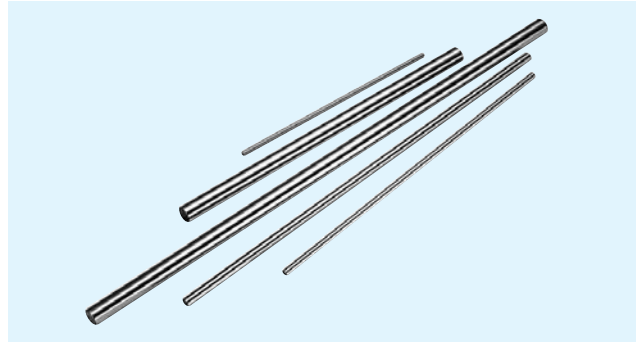

part number	outer diameter		length L		mass ℓ bs/inch kg/m
	D inch mm	tolerance g6* inch/μm	inch mm	inch mm	
SNW 4	1/4 6.350	-.0002 -.0006	3.94 100	39.37 1000	0.014 0.25
SNW 6	3/8 9.525	-5 -14	7.84 200	59.06 1500	0.031 0.56
SNW 8	1/2 12.700	-.0002 -.0007	7.84 200	118.11 3000	0.056 0.99
SNW10	5/8 15.875	-6 -17	7.84 200	157.48 4000	0.086 1.55
SNW12	3/4 19.050	-.0003 -.0008	11.81 300	157.48 4000	0.125 2.24
SNW16	1 25.400	-7 -20	11.81 300	157.48 4000	0.222 3.98
SNW20	1-1/4 31.750	-.0004 -.0010	11.81 300	157.48 4000	0.420 6.22
SNW24	1-1/2 38.100	-9 -25	15.75 400	157.48 4000	0.500 8.95
SNW32	2 50.800	-.0004	19.69 500	157.48 4000	0.890 15.91
SNW40	2-1/2 63.500	-.0011 -10 -29	23.62 600	157.48 4000	1.391 25.00
SNW48	3 78.200		23.62 600	157.48 4000	2.003 37.92
SNW64	4 101.600	-.0005/-0.0013 -12/-34	39.37 1000	157.48 4000	3.560 64.02

material : high-carbon chromium bearing steel (SUJ2)
hardness : HV 697 (60HRC) or more
Tolerances other than *g6 are available upon request.
Longer lengths are also available.

1kg ≅ 2.205 ℓ bs

SNWS TYPE

— NB Inch Stainless Steel Shaft —

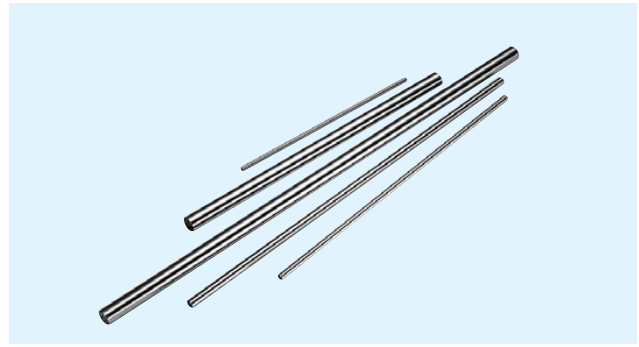

part number	structure
example	SNWS 24 h5 × 4000 mm
SNWS type	length (L)
size	outer diameter tolerance g6 when blank

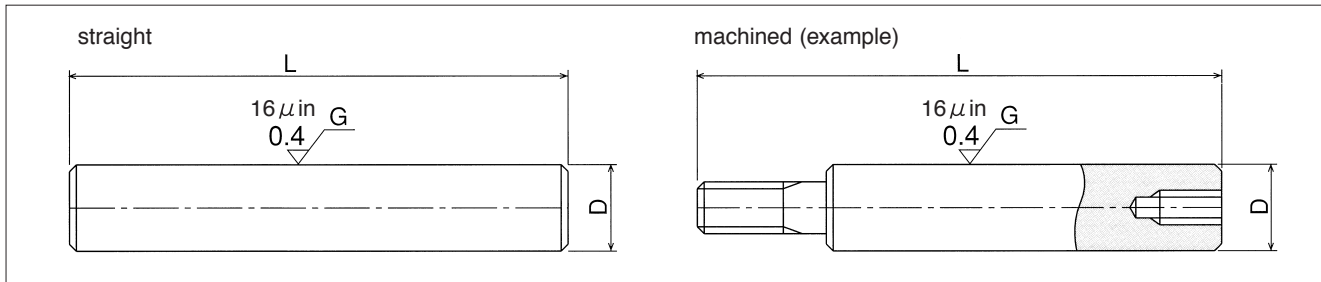

part number	outer diameter		length L inch mm	mass ℓ bs/inch kg/m
	D inch mm	tolerance g6* inch/μm		
SNWS 4	1/4 6.350	-.0002 -.0006	3.94 100 ← → 23.62 600	0.014 0.25
SNWS 6	3/8 9.525	-.0005 -.014	7.84 200 ← → 39.37 1000	0.031 0.55
SNWS 8	1/2 12.700	-.0002 -.0007	7.84 200 ← → 98.43 2500	0.056 0.98
SNWS10	5/8 15.875	-.0006 -.017	7.84 200 ← → 118.11 3000	0.086 1.54
SNWS12	3/4 19.050	-.0003 -.0008	11.81 300 ← → 157.48 4000	0.125 2.22
SNWS16	1 25.400	-.0007 -.020	11.81 300 ← → 157.48 4000	0.222 3.95
SNWS20	1-1/4 31.750	-.0004 -.0010	11.81 300 ← → 157.48 4000	0.420 6.16
SNWS24	1-1/2 38.100	-.0009 -.025	15.75 400 ← → 157.48 4000	0.500 8.88
SNWS32	2 50.800	-.0004/-0011 -10/-29	19.69 500 ← → 157.48 4000	0.890 15.78

material : Martensite stainless steel (equivalent to SUS440C)

1kg ≅ 2.205 ℓ bs

hardness : HV 613 (56HRC) or more

Tolerances other than *g6 are available upon request.

Longer lengths are also available.



PACIFIC INTERNATIONAL BEARING SALES, INC.
 800.228.8895 • WWW.PACIFICBEARINGSALES.COM

SNW-PD

– NB Inch Pre-Drilled Shaft –

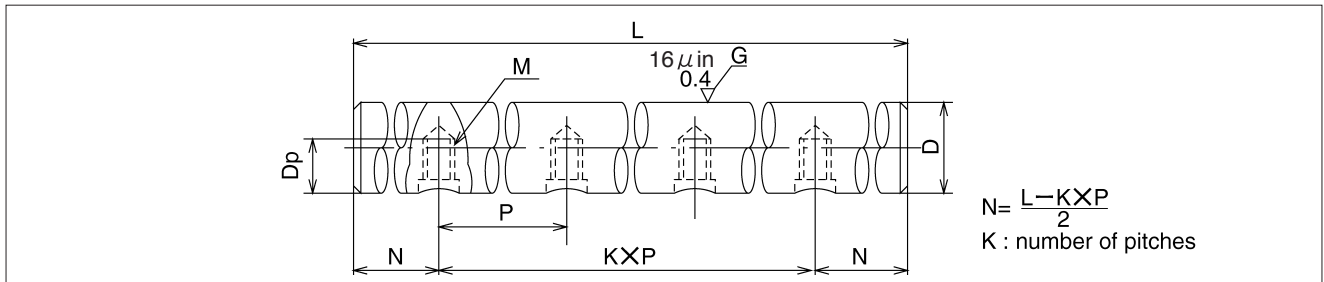
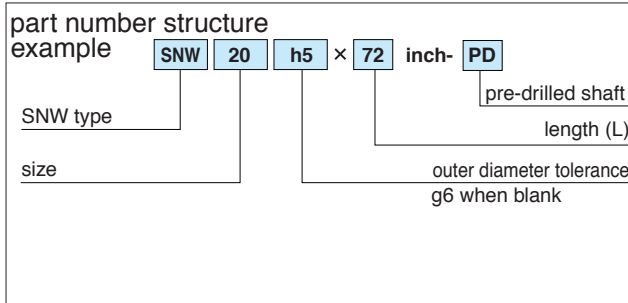
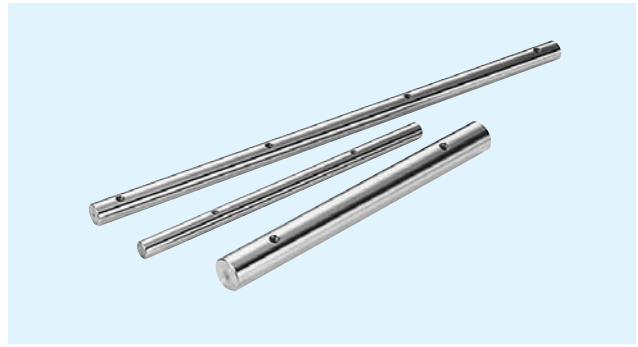

part number	outer diameter		pitch P inch/mm	bolt size M	tapped hole depth Dp inch/mm	maximum length L inch/mm
	D inch mm	tolerance g6* inch/μm				
SNW 8-PD	1/2 12.700	-.0002 -.0007	4 101.6	#6-32	0.280 7.1	72 1,828.8
SNW10-PD	5/8 15.875	-6 -17		8-32	0.350 8.9	
SNW12-PD	3/4 19.050	-.0003 -.0008	6 152.4	10-32	0.400 10.2	
SNW16-PD	1 25.400	-7 -20		1/4-20	0.500 12.7	
SNW20-PD	1-1/4 31.750	-.0004 -.0010		5/16-18	0.650 16.5	
SNW24-PD	1-1/2 38.100	-9 -25	3/8-16	0.700 17.8		
SNW32-PD	2 50.800	-.0004/- .0011 -10/-29	8 203.2	1/2-13	0.850 21.6	

material : high-carbon chromium bearing steel (SUJ2) .

1kg ≅ 2.205 lb

hardness : HV 697 (60HRC) or more

Tolerances other than *g6 are available upon request,

Longer lengths are also available.



PACIFIC INTERNATIONAL BEARING SALES, INC.

800.228.8895 • WWW.PACIFICBEARINGSALES.COM

SNWS-PD

– NB Inch Pre-Drilled Stainless Steel Shaft –

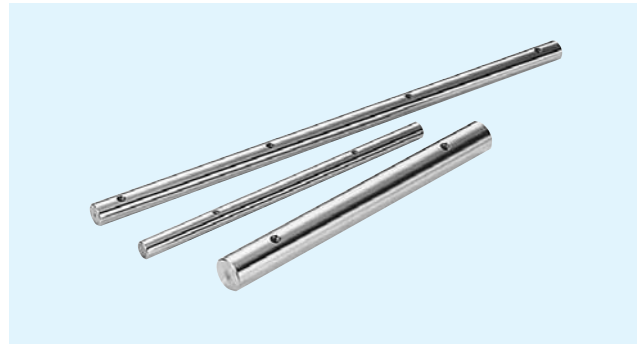

part number	structure
example	SNWS 24 h5 × 72 inch- PD
SNWS type	pre-drilled shaft
size	length (L) outer diameter tolerance g6 when blank

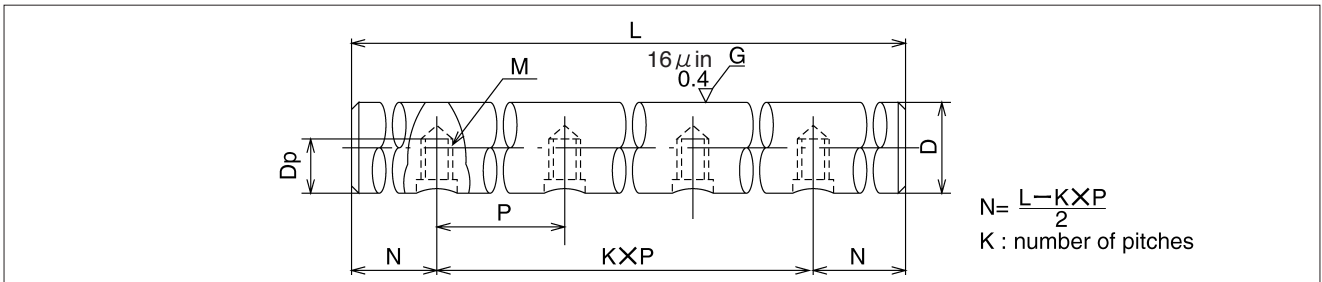

part number	outer diameter		pitch P inch/mm	bolt size M	tapped hole depth Dp inch/mm	maximum length L inch/mm
	D inch mm	tolerance g6* inch/μm				
SNWS12-PD	3/4 19,050	-.0003 -.0008	6 152.4	# 10-32	0.400 10.2	72 1,828.8
SNWS16-PD	1 25,400	-7 -20		1/4-20	0.500 12.7	
SNWS20-PD	1-1/4 31,750	-.0004 -.0010		5/16-18	0.650 16.5	
SNWS24-PD	1-1/2 38,100	-9 -25	8 203.2	3/8-16	0.700 17.8	
SNWS32-PD	2 50,800	-.0004/-0.0011 -10/-29		1/2-13	0.850 21.6	

material : Martensite stainless steel (equivalent to SUS440C)

hardness : HV613 (56HRC) or more

Tolerances other than *g6 are available upon request.

Longer lengths are also available.



PACIFIC INTERNATIONAL BEARING SALES, INC.
800.228.8895 • WWW.PACIFICBEARINGSALES.COM