



## SLIDE ROTARY SERIES

NB's Slide Rotary Series consists of three different types. The Slide Rotary Bush, which provides both endless rotary and linear motion functions, the Flanged Slide Rotary Bush, and the Slide Rotary Unit which is assembled using various NB standard housings.

The NB Slide Rotary Series has an idealistic structure, incorporating a combination of linear and rotary motion. Linear and rotary motion are merged into a single unit resulting in great space savings compared to the conventional style of Slide Bushings. All three types of the Slide Rotary Series are available in sizes ranging from 6mm to 30mm. All components in the Slide Rotary Series are standardized for versatile installation requirements.

### STRUCTURE AND ADVANTAGEOUS FEATURES

NB Slide Rotary Bush is composed of retainer fitted into cylindrical steel outer race and is designed to guide steel balls for smooth circulation in its retainer. The retainer is also designed to rotate freely towards radial direction and offers smooth linear and rotary motions.

#### Smooth Operation

The inner surface of the outer surface allows smooth operation of linear and rotary motions while maintaining a uniform load distribution.

#### High Load Acceptability

The use of comparatively large diameter steel balls enhances acceptability of high load capacity.

#### Smooth Rotation

The positioning of the steel balls in a cylindrical formation inside the retainer enables a smooth rotational motion to be achieved independent of the installation direction.

#### Complete Interchangeability

NB Slide Rotary series is completely interchangeable with SM type Slide Bush, SMK type Flanged Slide Bush and Slide Units such as SMA(W) type, AK(W) type and SMP type.

Figure F-3 Structure of SRE-type NB slide rotary bush

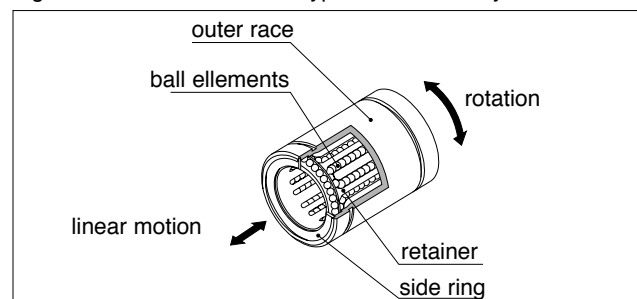



## RATED LIFE AND LOADS

The rated life and loads are defined as follows.

### Rated Life

When a group of slide rotary bearings of the same type are used under the same conditions, the rated life is defined as the total number of rotations made without flaking by 90% of the bearings.

### Basic Dynamic Rated Load

The basic dynamic rated load is defined as the load with a constant magnitude and direction at which a rated life of  $10^6$  rotations can be achieved.

### Basic Static Rated Load

The basic static rated load is defined as the load with a constant direction that would result in a certain contact stress at the mid-point of the rolling element and tracking surface that are experiencing the maximum stress.

Formula 1 gives the relation between the applied load and the rated life of the slide rotary bush.

### Calculation Example

The life of an SRE20-type NB slide rotary bush is calculated below based on the following operating conditions.

#### Conditions

- Motions : Linear and rotational, combined
- Load, P : 30 N
- Stroke, S : 200 mm
- Number of rotations per minute (rpm), n=15

#### Calculation:

Basic rated load, C=647 N

Based on the above operating conditions, the life is calculated using the following coefficient values.

Hardness coefficient,  $f_H=1$  Temperature coefficient,  $f_T=1$  Contact coefficient,  $f_C=1$  Load coefficient,  $f_W=1.5$   
Rated life

$$L = \left( \frac{f_H \cdot f_T \cdot f_C}{f_W} \cdot \frac{C}{P} \right)^3$$

$$= \left( \frac{1 \times 1 \times 1}{1.5} \times \frac{647}{30} \right)^3 = 2,972 \text{ (} 10^6 \text{ rotations)}$$

$$L = \left( \frac{f_H \cdot f_T \cdot f_C}{f_W} \cdot \frac{C}{P} \right)^3 \dots\dots\dots ①$$

L : rated life ( $10^6$  rotations)  $f_H$  : hardness coefficient  
 $f_T$  : temperature coefficient  $f_C$  : contact coefficient  
 $f_W$  : load coefficient C : basic dynamic rated load (N)  
P : applied load (N)

Since the slide rotary bush is used in applications with combined linear and rotary motions, the life time is obtained using Formulas ② and ③.

When linear and rotary motions are combined

$$L_h = \frac{10^6 \cdot L}{60 \sqrt{(dm \cdot n)^2 + (10 \cdot S \cdot n_1)^2} / dm} \dots\dots\dots ②$$

When only linear motion is involved

$$L_h = \frac{10^6 \cdot L}{600 \cdot S \cdot n_1 / \pi \cdot dm} \dots\dots\dots ③$$

$L_h$  : life (hours) S : stroke (mm) n : number of rotations per minute (rpm)  $n_1$  : number of strokes per minute (cpm)  
dm : ball pitch diameter (mm) = approx. 1.15 dr (dr is the inner contact diameter of the SRE-type bush)

- Number of strokes per minute (cpm),  $n_1=10$
- Shaft surface hardness : greater than 58 HRC
- Operating temperature : room temperature
- Other : single shaft with single bush

Life (in time)

$$L_h = \frac{10^6 \cdot L}{60 \sqrt{(dm \cdot n)^2 + (10 \cdot S \cdot n_1)^2} / dm}$$

$$L_h = \frac{10^6 \cdot L}{60 \sqrt{(1.15 \times 20 \times 15)^2 + (10 \times 200 \times 10)^2} / (1.15 \times 20)}$$

$$= 56,900 \text{ (hours)}$$

## Application Examples

Application Example 1 Vertical Shaft Robot Arm

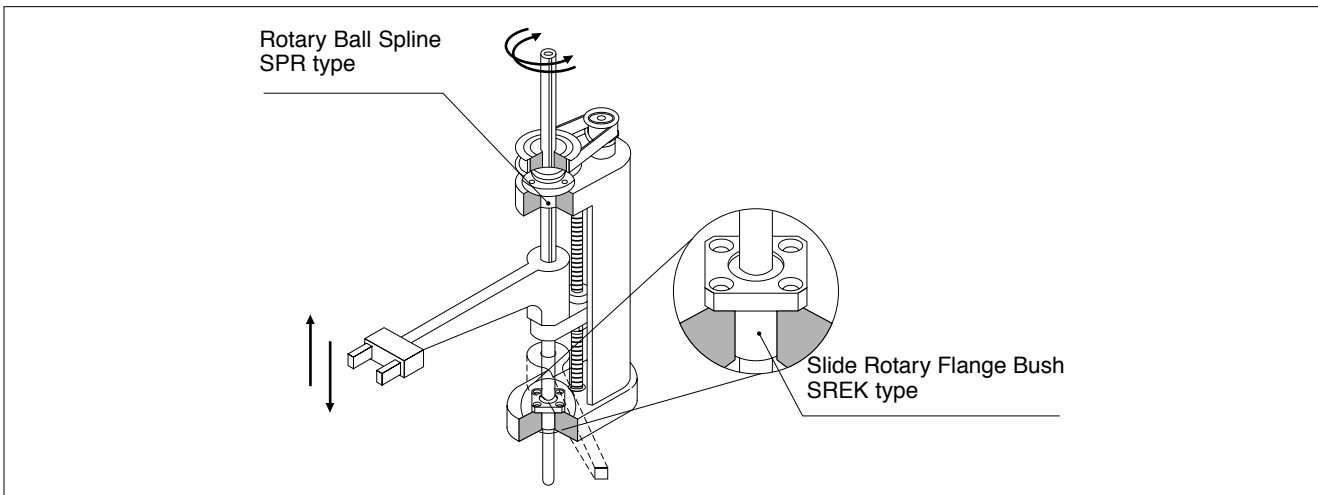

Application Example 2 Multiple Gearing Idler

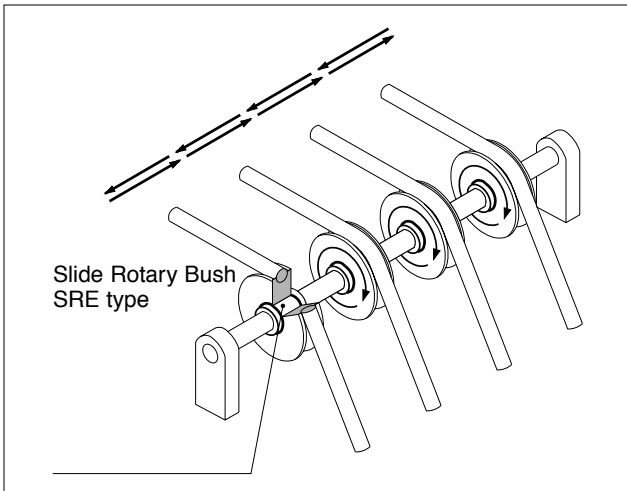

Application Example 3 Tool Changer

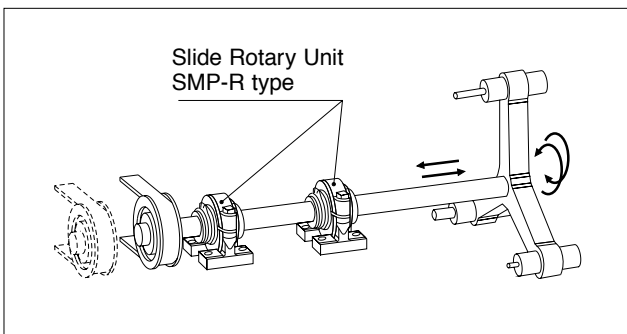

Application Example 4 Turntable

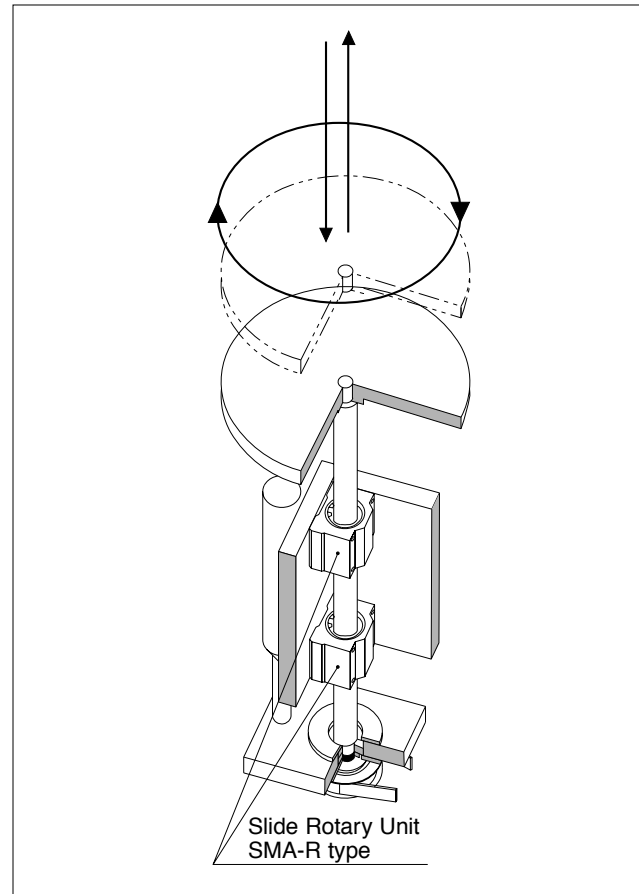



## Precautions Regarding Use

### Shaft

Since the balls roll directly over the shaft surface in the SRE-type slide rotary bush, the accuracy and hardness of the shaft are important factors.

Outer Diameter : A tolerance of g6 is recommended for smooth operation.

Hardness : A hardness of greater than 58HRC is recommended for long life. If the hardness is less than 58 HRC, the life is calibrated using the hardness coefficient.

Surface Roughness : A roughness of less than Ra0.4 is recommended.

### Housing

An inner diameter tolerance of H7 is recommended.

### Lubrication

Lubrication is needed (1) to prevent heat fusing and reduce wear between the rolling elements and between the rolling elements and the tracking surface, (2) to reduce wear of the structural elements, and (3) to prevent oxidation. Lubrication affects both the performance and life of the bush. A lubrication

method and a lubrication agent appropriate to the operating conditions should be used. For oil lubrication, turbine oil (V32-68) should be used. For grease lubrication, lithium soap grease no. 2 should be used. The frequency of lubrication depends on the operating conditions.

### Dust Control

Dust and other contaminants affect the bush's lifetime and accuracy. Appropriate control methods are thus important.

### Operating Temperature Range

The SRE-type bush can be operated at temperatures ranging from  $-20^{\circ}\text{C}$  to  $110^{\circ}\text{C}$ . In a case of operating at a temperature outside this range, please contact NB.

### Retainer Material

The standard material of SRE Retainer is "Phosphor Bronze". When requiring other material, please contact NB.

## Felt Seal

The use of an FLM felt seal will improve the effectiveness of lubrication and extend the interval between applications of a lubricant.

Figure F-4 Felt seal diagram

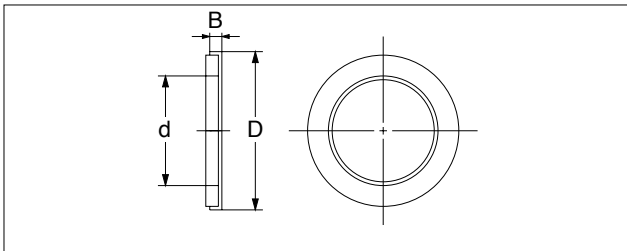

### Installation

The felt seal should be installed as shown in Figure F-5. Please note that felt seal is not designed for stopper function.

Table F-2 Felt seal dimensions

part number	major dimensions			applicable slide rotary bush
	d	D	B	
FLM 6	6	12	2	SRE 6
FLM 8	8	15	2	SRE 8
FLM10	10	19	3	SRE10
FLM12	12	21	3	SRE12
FLM13	13	23	3	SRE13
FLM16	16	28	4	SRE16
FLM20	20	32	4	SRE20
FLM25	25	40	5	SRE25
FLM30	30	45	5	SRE30

Figure F-5 Example of Installation

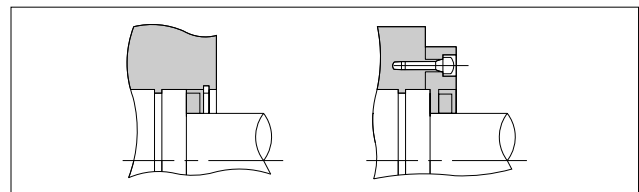

# SRE TYPE

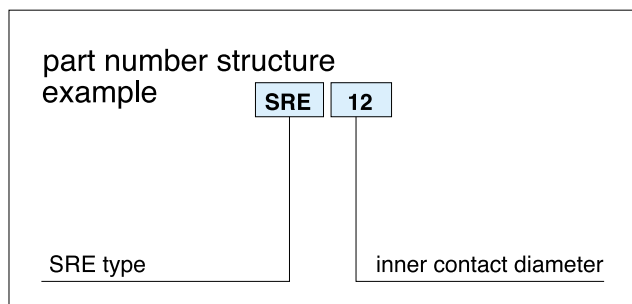

part number	major dimensions							
	inner contact diameter		D		L		B	
	dr	tolerance		tolerance		tolerance		tolerance
	mm	$\mu$ m	mm	mm	mm	mm	mm	mm
<b>SRE 6</b>	6	+4 -5	12	0	19	0 -0.2	13.5	0 -0.2
<b>SRE 8</b>	8		15	-11	24		17.5	
<b>SRE10</b>	10		19		29		22	
<b>SRE12</b>	12	+3 -6	21	0	30	-0.2	23	-0.2
<b>SRE13</b>	13		23	-13	32		23	
<b>SRE16</b>	16		28		37		26.5	
<b>SRE20</b>	20	+3 -7	32	0	42	0 -0.3	30.5	0 -0.3
<b>SRE25</b>	25		40	-16	59		41	
<b>SRE30</b>	30		45		64		44.5	

\*If the inner contact diameter exceeds 30 mm, please contact NB.



# SLIDE ROTARY BUSH

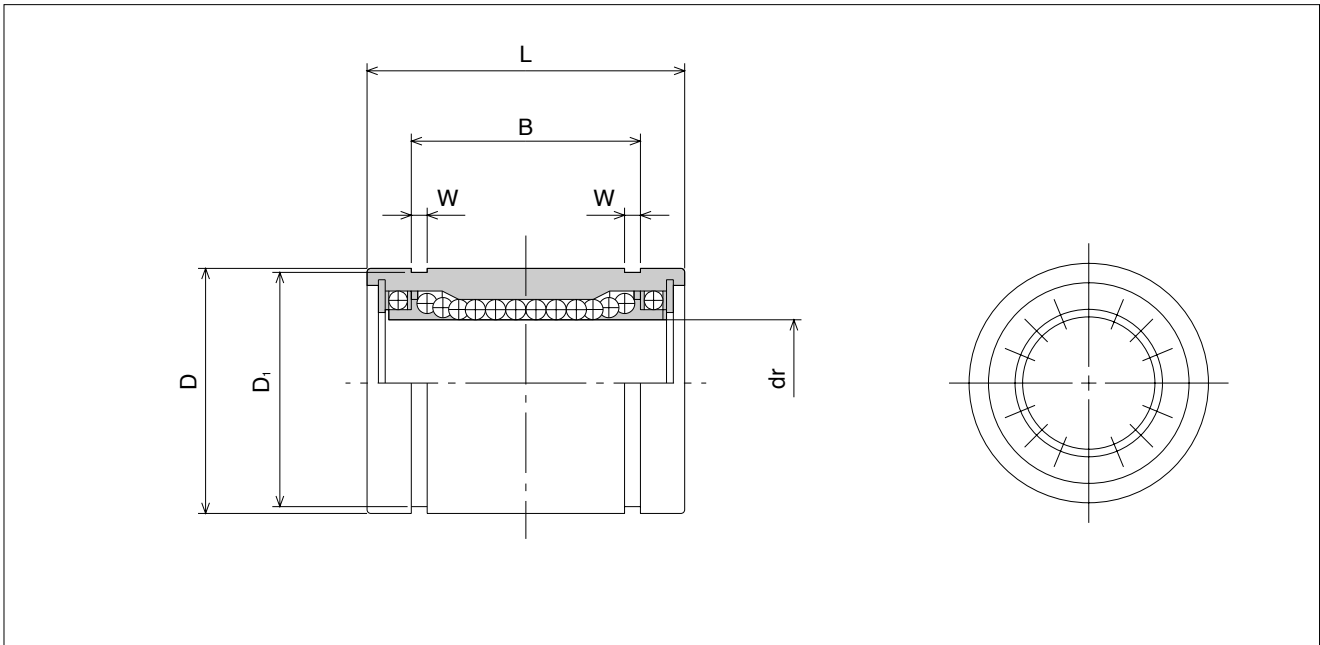

W	D <sub>1</sub>	basic load rating		allowable number of rotations per minute	number of ball circuit	mass	part number
		dynamic C	static C <sub>0</sub>				
mm	mm	N	N	rpm		g	
1.1	11.5	78	176	300	6	9	<b>SRE 6</b>
1.1	14.3	137	314	300	8	15	<b>SRE 8</b>
1.3	18	157	372	300	8	20	<b>SRE10</b>
1.3	20	274	588	300	8	40	<b>SRE12</b>
1.3	22	323	686	300	8	45	<b>SRE13</b>
1.6	27	451	882	250	8	65	<b>SRE16</b>
1.6	30.5	647	1,180	250	8	110	<b>SRE20</b>
1.85	38	882	1,860	250	8	210	<b>SRE25</b>
1.85	43	1,180	2,650	200	8	290	<b>SRE30</b>

1N ≅ 0.102kgf



PACIFIC INTERNATIONAL BEARING SALES, INC.  
800.228.8895 • WWW.PACIFICBEARINGSALES.COM

# SREK TYPE

– Square Flange type –

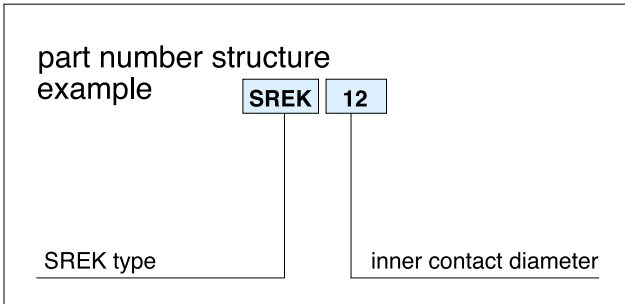
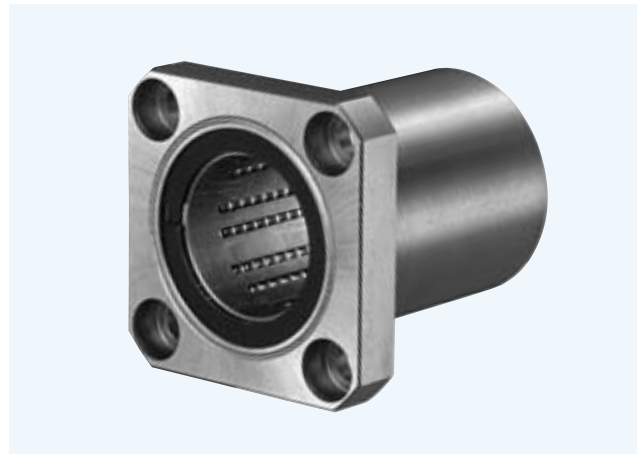

part number	major dimensions						
	inner contact diameter		D		L ±0.3	Df	K
	dr mm	tolerance μm	mm	tolerance μm			
<b>SREK 6</b>	6	+4 -5	12	0	19	28	22
<b>SREK 8</b>	8		15	-13	24	32	25
<b>SREK10</b>	10	+3 -6	19	0 -16	29	40	30
<b>SREK12</b>	12		21		30	42	32
<b>SREK13</b>	13		23		32	43	34
<b>SREK16</b>	16	+3 -7	28	0 -19	37	48	37
<b>SREK20</b>	20		32		42	54	42
<b>SREK25</b>	25		40		59	62	50
<b>SREK30</b>	30		45		64	74	58



# SLIDE ROTARY BUSH

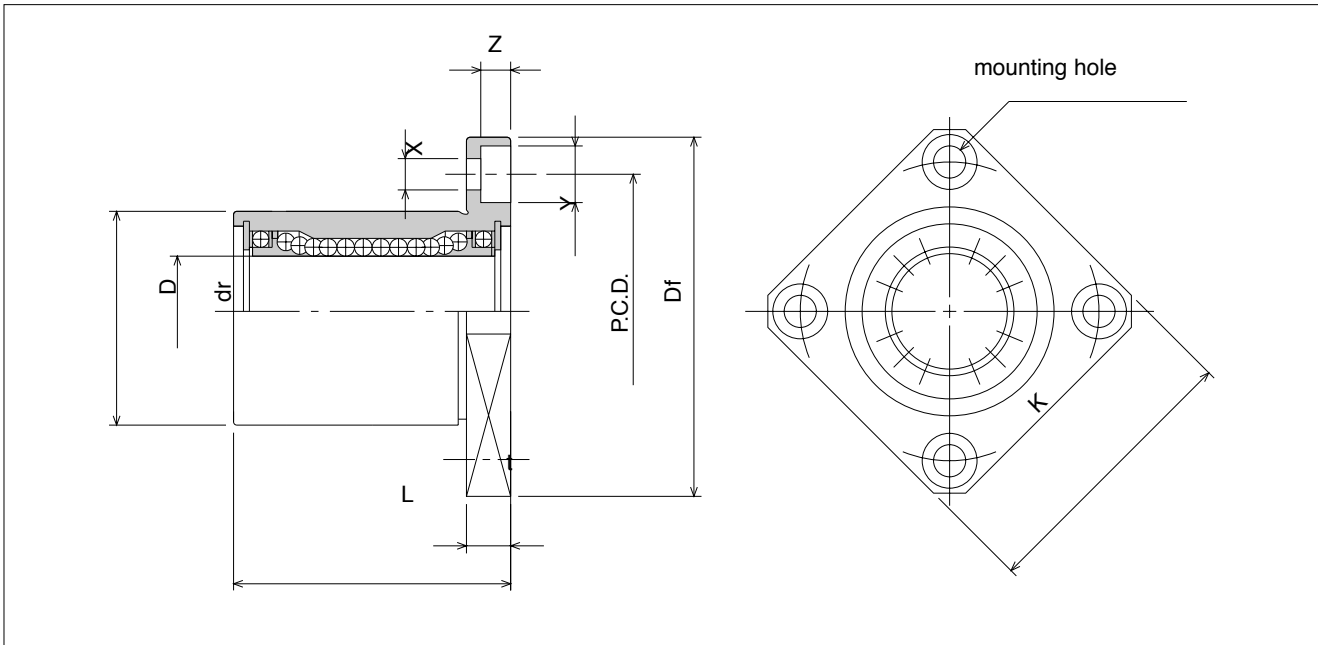

flange			perpendicularity	basic load rating		allowable rotational speed	mass	part number
t	P.C.D	X×Y×Z		dynamic	static			
mm	mm	mm	μm	C	C <sub>0</sub>	rpm	g	
5	20	3.5×6×3.1	12	78	176	300	19	<b>SREK 6</b>
5	24	3.5×6×3.1		137	314	300	27	<b>SREK 8</b>
6	29	4.5×7.5×4.1		157	372	300	36	<b>SREK10</b>
6	32	4.5×7.5×4.1		274	588	300	55	<b>SREK12</b>
6	33	4.5×7.5×4.1		323	686	300	68	<b>SREK13</b>
6	38	4.5×7.5×4.1		451	882	250	93	<b>SREK16</b>
8	43	5.5×9×5.1	15	647	1,180	250	155	<b>SREK20</b>
8	51	5.5×9×5.1		882	1,860	250	270	<b>SREK25</b>
10	60	6.6×11×6.1		1,180	2,650	200	395	<b>SREK30</b>

1N ≅ 0.102kgf



PACIFIC INTERNATIONAL BEARING SALES, INC.  
800.228.8895 • WWW.PACIFICBEARINGSALES.COM



# SLIDE ROTARY UNIT

## SMA-R TYPE

— Block type —

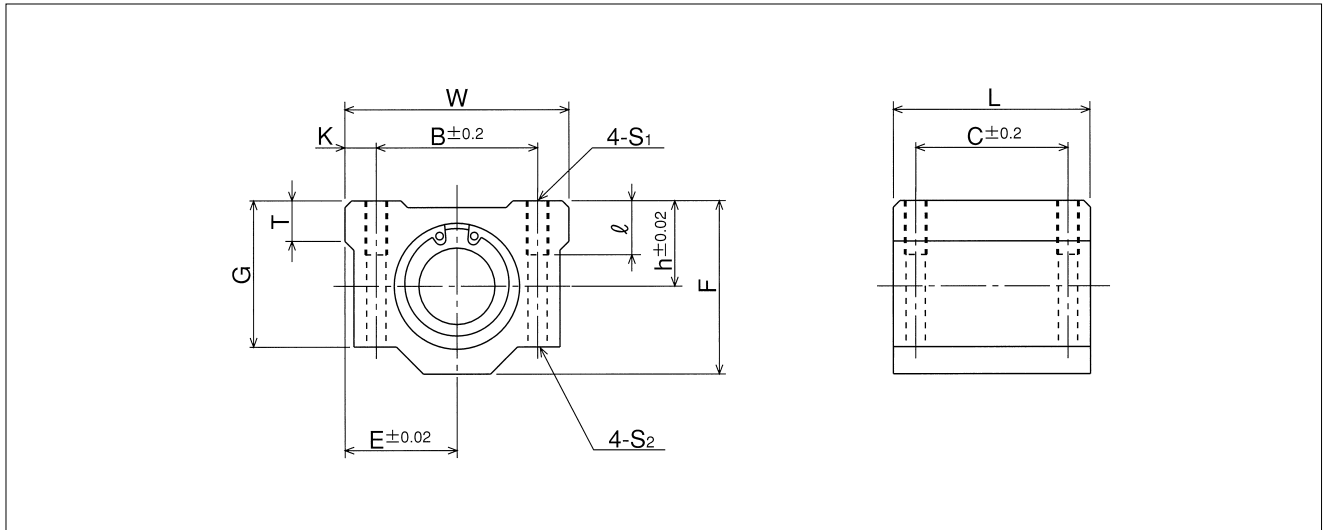
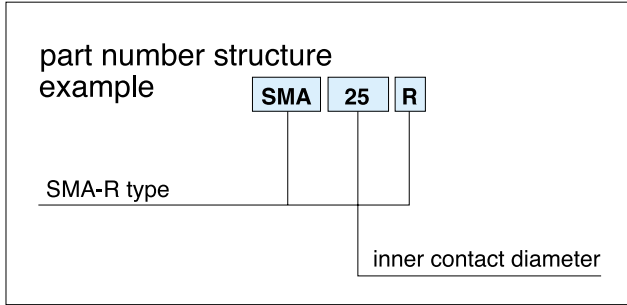

part number	major dimensions															basic load rating		mass
	inner contact diameter		outer dimensions							mounting dimensions						dynamic	static	
	mm	μm	h	E	W	L	F	G	T	B	C	K	S <sub>1</sub>	ℓ	S <sub>2</sub>	C	C <sub>0</sub>	
		tolerance	mm	mm	mm	mm	mm	mm	mm	mm	mm	mm		mm	mm	N	N	
SMA 6R	6		9	15	30	25	18	15	6	20	15	5	M4	8	3.4	78	176	35
SMA 8R	8	+4	11	17	34	30	22	18	6	24	18	5	M4	8	3.4	137	314	50
SMA10R	10	-5	13	20	40	35	26	21	8	28	21	6	M5	12	4.3	157	372	76
SMA12R	12		15	21	42	36	28	24	8	30.5	26	5.75	M5	12	4.3	274	588	100
SMA13R	13	+3	15	22	44	39	30	24.5	8	33	26	5.5	M5	12	4.3	323	686	116
SMA16R	16	-6	19	25	50	44	38.5	32.5	9	36	34	7	M5	12	4.3	451	882	189
SMA20R	20		21	27	54	50	41	35	11	40	40	7	M6	12	5.2	647	1,180	265
SMA25R	25	+3	26	38	76	67	51.5	42	12	54	50	11	M8	18	7	882	1,860	570
SMA30R	30	-7	30	39	78	72	59.5	49	15	58	58	10	M8	18	7	1,180	2,650	755

1N≒0.102kgf



# SLIDE ROTARY UNIT

## SMA-RW TYPE

– Double-Wide Block type –

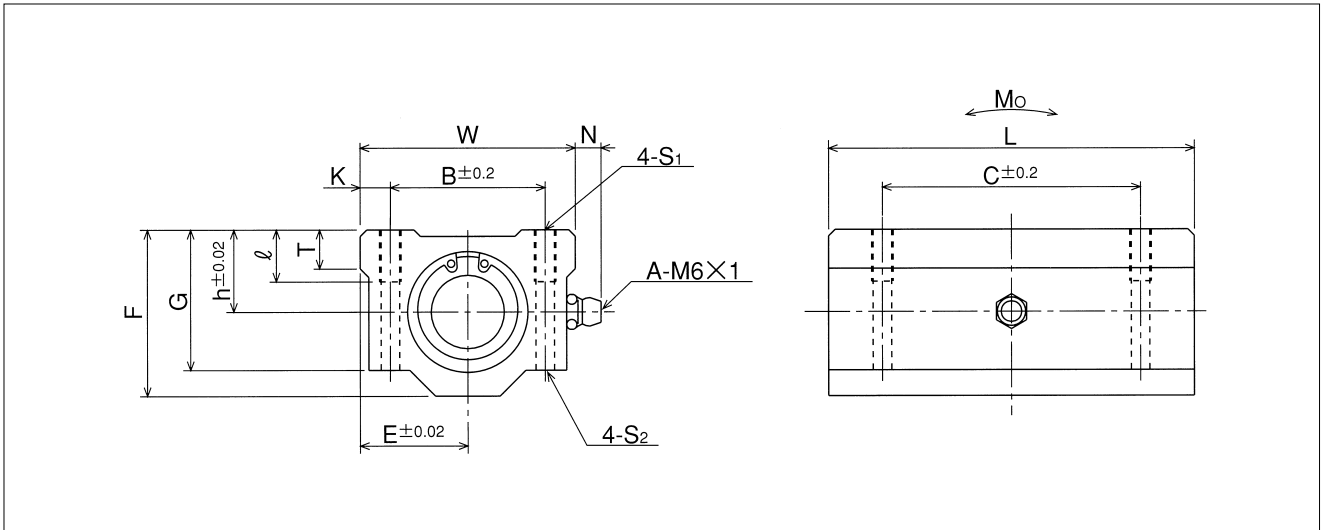
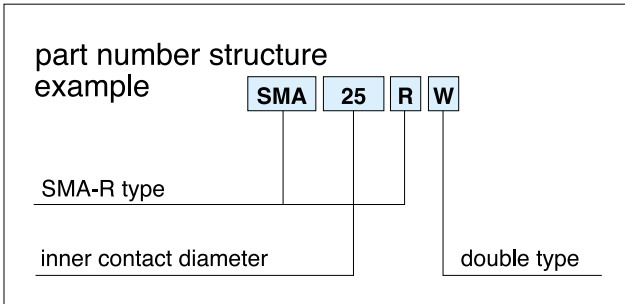

part number	major dimensions															basic load rating		mass	
	inner contact diameter		outer dimensions								mounting dimensions					dynamic	static		
	mm	μm	h	E	W	L	F	G	T	N	B	C	K	S <sub>1</sub>	ℓ	S <sub>2</sub>	C		C <sub>0</sub>
SMA 6RW	6		9	15	30	48	18	15	6	7	20	36	5	M4	8	3.4	126	352	64
SMA 8RW	8	+4	11	17	34	58	22	18	6	7	24	42	5	M4	8	3.4	222	628	98
SMA10RW	10	-5	13	20	40	68	26	21	8	7	28	46	6	M5	12	4.3	254	744	148
SMA12RW	12		15	21	42	70	28	24	8	6.5	30.5	50	5.75	M5	12	4.3	444	1,180	201
SMA13RW	13	+3	15	22	44	75	30	24.5	8	6.5	33	50	5.5	M5	12	4.3	523	1,370	232
SMA16RW	16	-6	19	25	50	85	38.5	32.5	9	6	36	60	7	M5	12	4.3	731	1,760	378
SMA20RW	20		21	27	54	96	41	35	11	7	40	70	7	M6	12	5.2	1,050	2,360	590
SMA25RW	25	+3	26	38	76	130	51.5	42	12	4	54	100	11	M8	18	7	1,430	3,720	1,140
SMA30RW	30	-7	30	39	78	140	59.5	49	15	5	58	110	10	M8	18	7	1,910	5,300	1,520

1N≒0.102kgf



PACIFIC INTERNATIONAL BEARING SALES, INC.  
800.228.8895 • WWW.PACIFICBEARINGSALES.COM

# SLIDE ROTARY UNIT

## AK-R TYPE

— Compact Block type —

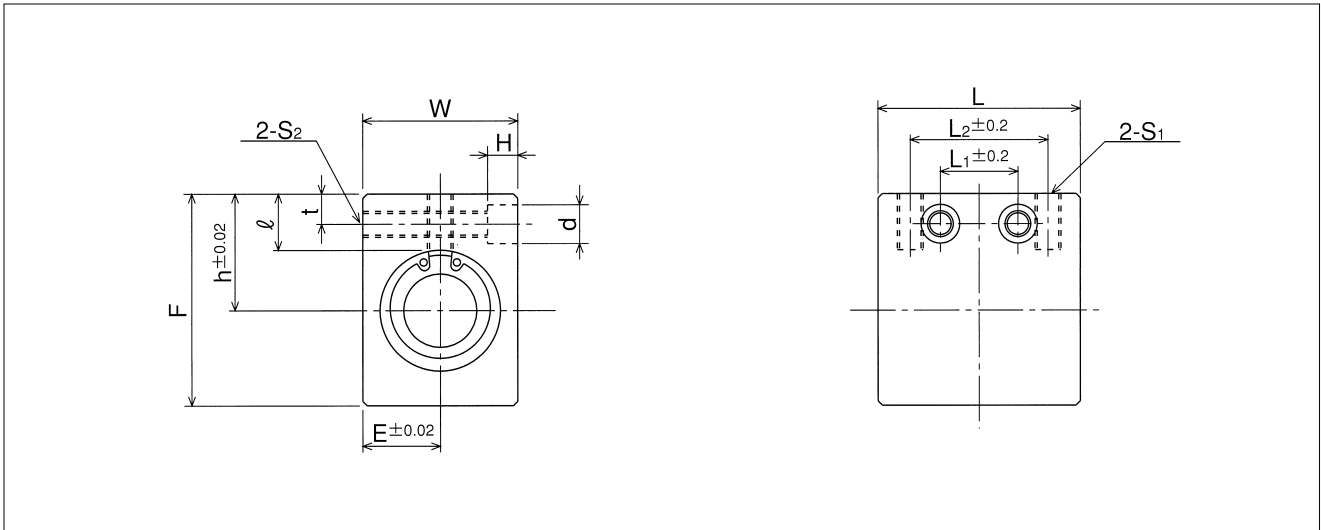
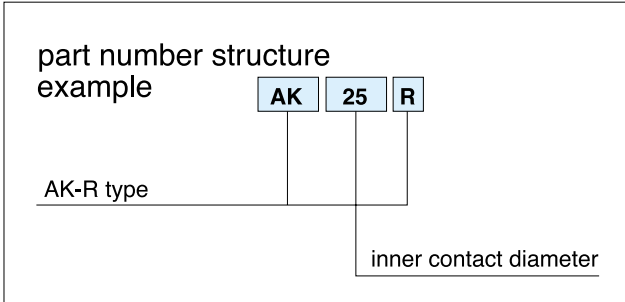

part number	major dimensions															basic load rating		mass
	inner contact diameter		outer dimensions					mounting dimensions								dynamic	static	
	mm	μm	h	E	W	L	F	L <sub>2</sub>	S <sub>1</sub>	ℓ	L <sub>1</sub>	t	S <sub>2</sub>	d	H	C	C <sub>0</sub>	
			mm	mm	mm	mm	mm	mm		mm	mm	mm		mm	mm	N	N	g
AK 6R	6		14	8	16	27	22	18	M 4	8	9	5	M 4	6	5	78	176	22
AK 8R	8	+4	16	10	20	32	26	20	M 5	8.5	10	5	M 4	6	5	137	314	38
AK10R	10	-5	19	13	26	39	32	27	M 6	9.5	15	6	M 5	8	6	157	372	64
AK12R	12		20	14	28	40	34	27	M 6	9.5	15	6	M 5	8	6	274	588	88
AK13R	13	+3	25	15	30	42	43	28	M 6	13.5	16	7	M 6	9	7	323	686	128
AK16R	16	-6	27	18	36	47	49	32	M 6	13	18	7	M 6	9	7	451	882	193
AK20R	20		31	21	42	52	54	36	M 8	15	18	8	M 8	11	8	647	1,180	282
AK25R	25	+3	37	26	52	69	65	42	M10	17	22	9	M10	14	10	882	1,860	544
AK30R	30	-7	40	29	58	74	71	44	M10	17.5	22	9	M10	14	10	1,180	2,650	730

## SLIDE ROTARY UNIT AK-RW TYPE

— Double-Wide Compact Block type —

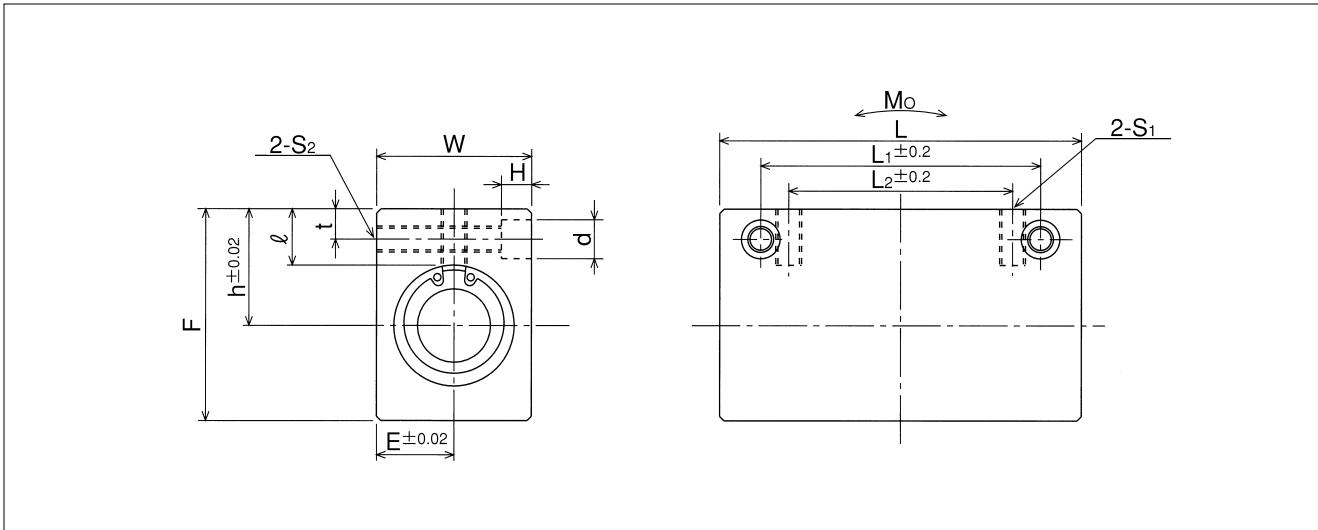
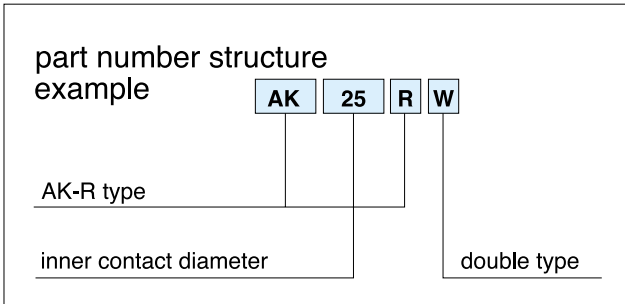

part number	major dimensions															basic load rating		
	inner contact diameter		outer dimensions					mounting dimensions								dynamic	static	mass
	mm	μm	h	E	W	L	F	L <sub>2</sub>	S <sub>1</sub>	ℓ	L <sub>1</sub>	t	S <sub>2</sub>	d	H	C	C <sub>0</sub>	g
AK 6RW	6		14	8	16	46	22	20	M 4	8	30	5	M 4	6	5	126	352	41
AK 8RW	8	+4	16	10	20	56	26	30	M 5	8.5	42	5	M 4	6	5	222	628	71
AK10RW	10	-5	19	13	26	68	32	36	M 6	9.5	50	6	M 5	8	6	254	744	118
AK12RW	12		20	14	28	70	34	36	M 6	9.5	50	6	M 5	8	6	444	1,180	164
AK13RW	13	+3	25	15	30	74	43	42	M 6	13.5	55	7	M 6	9	7	523	1,370	240
AK16RW	16	-6	27	18	36	84	49	52	M 6	13	65	7	M 6	9	7	731	1,760	361
AK20RW	20		31	21	42	94	54	58	M 8	15	70	8	M 8	11	8	1,050	2,360	540
AK25RW	25	+3	37	26	52	128	65	80	M10	17	100	9	M10	14	10	1,430	3,720	1,060
AK30RW	30	-7	40	29	58	138	71	90	M10	17.5	110	9	M10	14	10	1,910	5,300	1,424

1N ≒ 0.102kgf



PACIFIC INTERNATIONAL BEARING SALES, INC.  
800.228.8895 • WWW.PACIFICBEARINGSALES.COM

# SLIDE ROTARY UNIT

## SMP-R TYPE

— Pillow Block type —

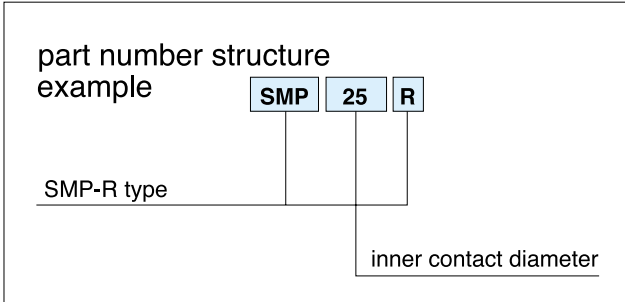

part number	major dimensions								
	inner contact diameter		outer dimensions						
		tolerance	h	E	W	L	F	G	M
	mm	$\mu\text{m}$	mm	mm	mm	mm	mm	mm	mm
<b>SMP13R</b>	13	+3	25	25	50	32	46	8	36
<b>SMP16R</b>	16	-6	29	27.5	55	37	53	10	40
<b>SMP20R</b>	20	+3 -7	34	32.5	65	42	62	12	48
<b>SMP25R</b>	25		40	38	76	59	73	12	59
<b>SMP30R</b>	30		45	42.5	85	64	84	15	69



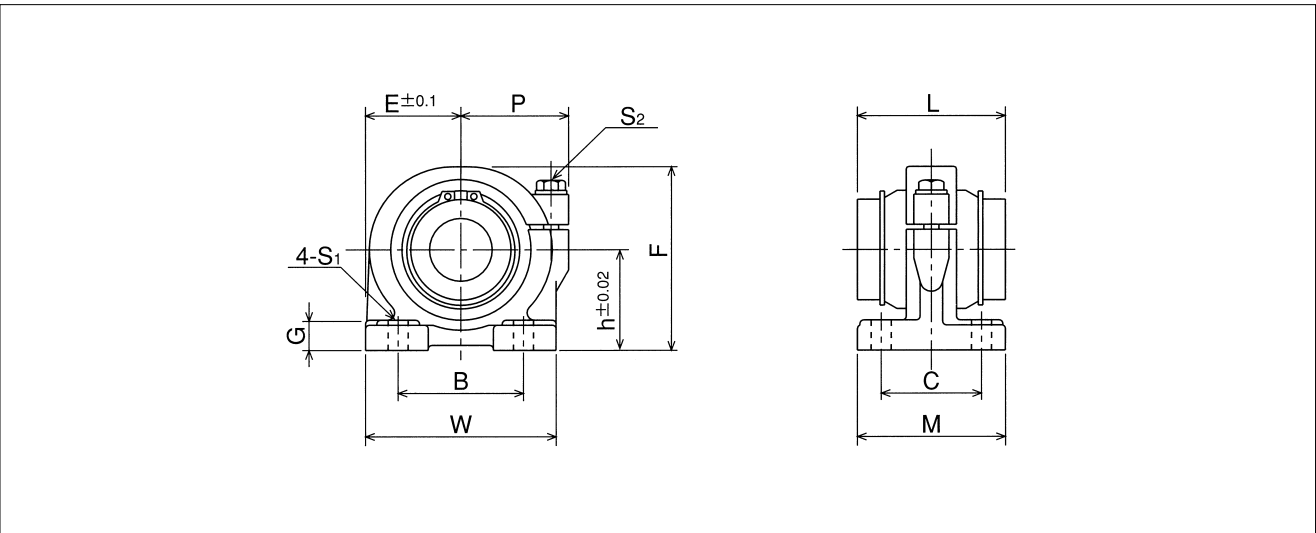

P	mounting dimensions			adjustment bolt size  S <sub>2</sub>	basic load rating		mass  g	part number
	B	C	S <sub>1</sub> (bolt size)		dynamic  C	static  C <sub>0</sub>		
mm	mm	mm	mm		N	N		
30	30	26	7 (M5)	M5	323	686	266	<b>SMP13R</b>
32	35	29	7 (M5)	M5	451	882	369	<b>SMP16R</b>
37	40	35	8 (M6)	M6	647	1,180	690	<b>SMP20R</b>
43	50	40	8 (M6)	M6	882	1,860	970	<b>SMP25R</b>
49	58	46	10 (M8)	M8	1,180	2,650	1,420	<b>SMP30R</b>

1N ≅ 0.102kgf

