

KBT TYPE

– Two Side Cut Flange Type –

KBT type is a metric dimension series generally used in Europe.

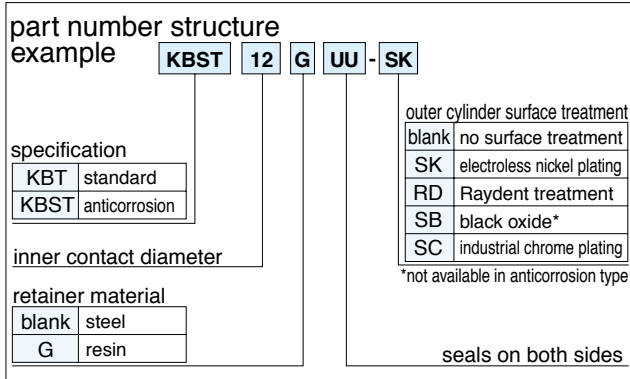

part number**				number of ball circuits	dr mm	tolerance μm	D		L ±0.3 mm
standard		anticorrosion					mm	tolerance μm	
steel retainer	resin retainer	stainless retainer	resin retainer						
KBT 5UU	KBT 5GUU	KBST 5UU	KBST 5GUU	4	5	+ 8	12	0	22
KBT 8UU	KBT 8GUU	KBST 8UU	KBST 8GUU	4	8	0	16	-13	25
KBT12UU	KBT12GUU	KBST12UU	KBST12GUU	4	12		22	0	32
KBT16UU	KBT16GUU	KBST16UU	KBST16GUU	4	16	+ 9	26	-16	36
KBT20UU	KBT20GUU	KBST20UU	KBST20GUU	5	20	- 1	32		45
KBT25UU	KBT25GUU	KBST25UU	KBST25GUU	6	25	+11	40	0	58
KBT30UU	KBT30GUU	KBST30UU	KBST30GUU	6	30	- 1	47	-19	68

** UU type is standard feature.



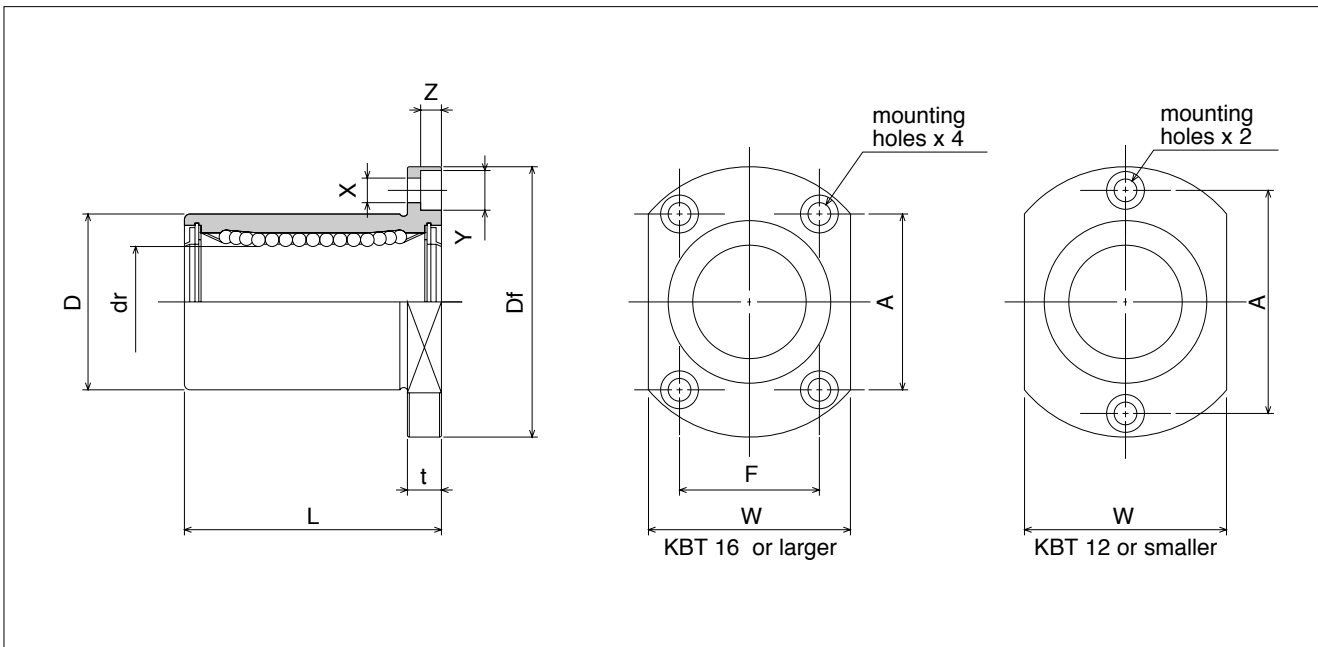

major dimensions						eccentricity	perpen- dicularity	basic load rating		mass	shaft diameter
flange								dynamic	static		
Df	W	t	A	F	X×Y×Z	μm	μm			C	Co
28	18	5	20	-	3.5×6×3.1	12	12	206	265	25	5
32	22	5	24	-	3.5×6×3.1			265	402	37	8
42	28	6	32	-	4.5×7.5×4.1			510	784	73	12
46	32	6	28	22	4.5×7.5×4.1			578	892	90	16
54	38	8	36	24	5.5×9×5.1	15	15	862	1,370	155	20
62	46	8	40	32	5.5×9×5.1			980	1,570	297	25
76	53	10	48	38	6.6×11×6.1			1,570	2,740	471	30

1N≒0.102kgf



PACIFIC INTERNATIONAL BEARING SALES, INC.
800.228.8895 • WWW.PACIFICBEARINGSALES.COM

SWT TYPE

– Two Side Cut Flange Type –

SWT type is an inch dimension series generally used in the U.S.

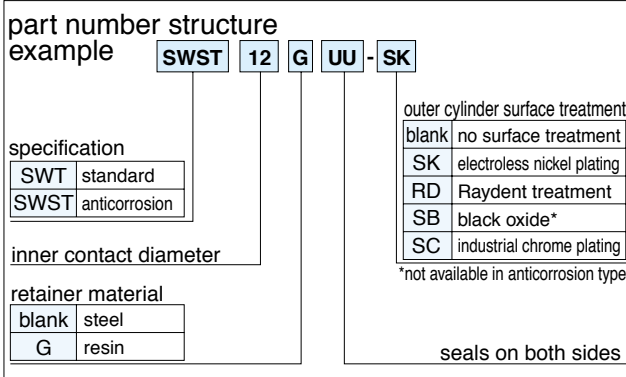
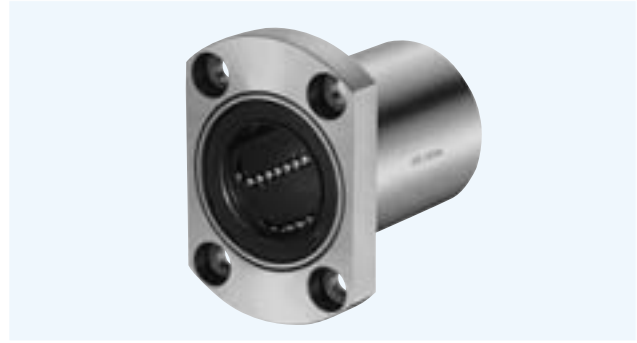

part number***				number of ball circuits	dr		D		L ±0.012 inch
standard		anticorrosion			inch	tolerance inch	inch	tolerance inch	
steel retainer	resin retainer	stainless retainer	resin retainer						
SWT 4UU	SWT 4GUU	SWST 4UU	SWST 4GUU	3****	.2500	0 -.00040	.5000	0/- .00050	.7500
SWT 6UU	SWT 6GUU	SWST 6UU	SWST 6GUU	4	.3750		.6250	0 -.00065	.8750
SWT 8UU	SWT 8GUU	SWST 8UU	SWST 8GUU	4	.5000		.8750	0 -.00075	1.2500
SWT10UU	SWT10GUU	SWST10UU	SWST10GUU	4	.6250		1.1250	0 -.00075	1.5000
SWT12UU	SWT12GUU	SWST12UU	SWST12GUU	5	.7500		1.2500	0 -.00075	1.6250
SWT16UU	SWT16GUU	SWST16UU	SWST16GUU	6	1.0000		1.5625	0 -.00075	2.2500
SWT20UU	SWT20GUU	SWST20UU	SWST20GUU	6	1.2500		0/- .00050	2.0000	0/- .00090

*** UU type is standard feature.

**** 4 rows for resin retainer type.



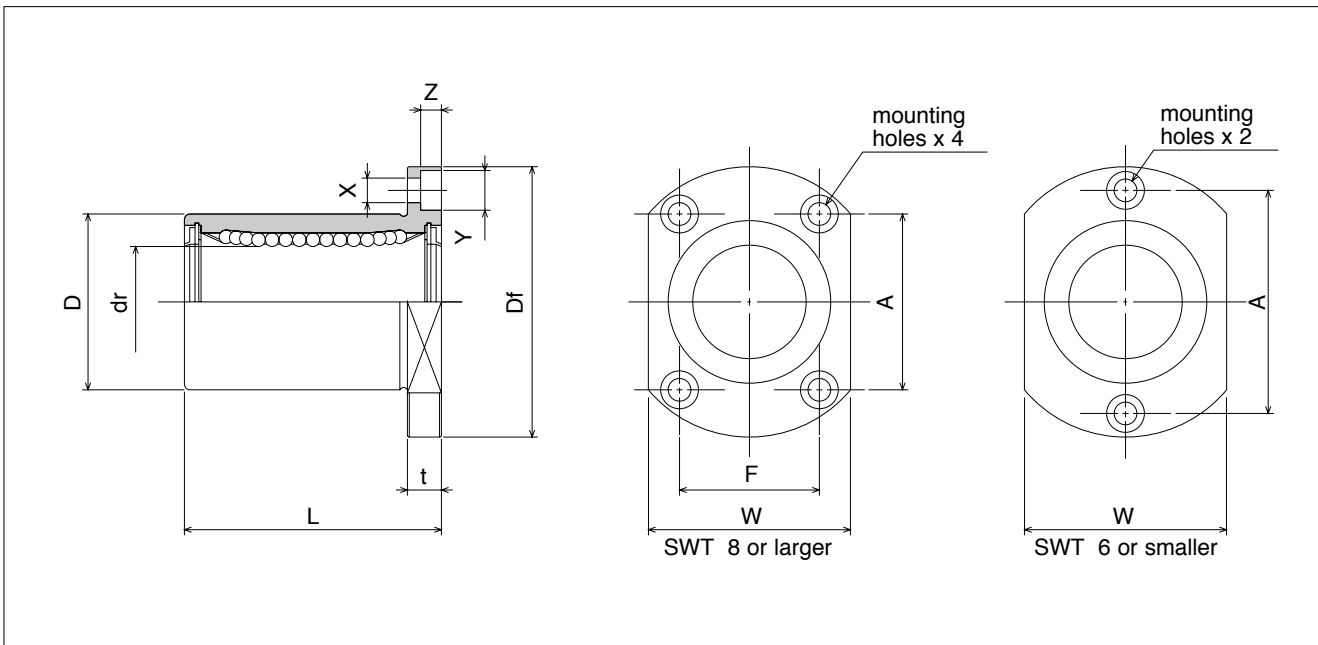

major dimensions						eccentricity	perpen- dicularity	basic load rating		mass	shaft diameter
flange								dynamic	static		
Df	W	t	A	F	X×Y×Z			C	Co		
inch	inch	inch	inch	inch	inch	inch	inch	N	N	g	inch
1.2500	.7500	.2190	.8750	-	.1560 × .2500 × .1410	.0005	.0005	206	265	28	1/4
1.5000	.8750	.2500	1.0625	-	.1875 × .2970 × .1720			225	314	44	3/8
1.7500	1.1250	.2500	1.1250	.6875	.1875 × .2970 × .1720			510	784	77	1/2
2.0000	1.3750	.2500	1.2500	.9375	.1875 × .2970 × .1720			774	1,180	125	5/8
2.1875	1.5000	.3125	1.3750	1.0000	.2187 × .3440 × .2030	.0006	.0006	862	1,370	162	3/4
2.5000	1.8750	.3125	1.5625	1.3125	.2187 × .3440 × .2030			980	1,570	293	1
3.1250	2.3750	.3750	1.8750	1.7500	.2812 × .4060 × .2656			1,570	2,740	586	1-1/4

1N ≅ 0.225 ℓ bs 1kg ≅ 2.205 ℓ bs



PACIFIC INTERNATIONAL BEARING SALES, INC.
800.228.8895 • WWW.PACIFICBEARINGSALES.COM