

Rod Ends and Spherical Plain Bearings



Introduction

Rod Ends and Spherical Plain Bearings are assembled machine parts to DIN ISO 12240 (former DIN 648), ready for installation. They are used to guarantee the unproblematic movement between shaft and housing, especially where the movement is not directly linear.

The **FLURO®** production program consists of Spherical Plain Bearings in all Series (DIN ISO 12240-1) and Rod Ends Series K and E (DIN ISO 12240-4), as well as Hydraulic Rod Ends with weld-on surface or female thread fixable with hexagon socket head cap screws. As new products in this catalogue are Thrust Bearings and Angular Contact Spherical Plain Bearings. To supplement the product range Angle Joints, Fork Heads, Locking Nuts and Rubber Seals have been added.

Where bearings with standard dimensions cannot be used, parts to customer designs are manufactured. Alternatively we can develop solutions for special applications. A small selection of these parts may be seen on the last pages of this catalogue. Our premium trained engineering and quality guarantee staff is pleased to offer advise on any application demand.

With high standard machinery we are able to turn, grind and mill parts with the highest precision. A list of our machining capabilities is available on request.

We have been approved for quality assurance to DIN EN ISO 9001 since June 1997.

Our sales staff is happy to assist you with any inquiry.

Just recently our industrial unit was enlarged and modernized. This meant advanced improvements to our logistics and an enlarged stock of products for faster delivery response.



Contents

General

Introduction	2
Contents	3
Contents	4
Production Program	5
FLUROGLIDE®/Motorsport	12
Ordering Details	13

Technical Data

Thread, Pivoting Angle	14
Fit, Installation	15
Internal Clearance	16
Lubrication, Temperature, Material	17
Technical Information	18
Calculation Examples	22

Rod Ends Series K

Standard GI/GA	24
Heavy Duty GIS/GAS	26
Extra Heavy Duty GIXS/GAXS	28
Heavy Duty Stainless Steel GIRS/GARS	30
Stainless Steel GIRS..R/GARS..R	32
Heavy Duty Maintenance Free GISW/GASW	34
ditto Extra Heavy Duty GIXSW/GAXSW	36
Heavy Duty Stainless Steel GIRSW/GARSW	38
Stainless Steel GIRSW..R/GARSW..R	40
ditto GIRSW..RR/GARSW..RR	42
ditto GIRSW..RR.316/GARSW..RR.316	44
ditto GIRSW..NIRO/GARSW..NIRO	46
Steel on Steel GIO/GAO	48
Steel/PTFE GIOW/GAOW	50
Rod Ends with Seals	52
ditto with Threaded Bolt	53
ditto for Pneumatic Cylinders	54

Spherical Plain Bearings Series K

Standard GL	55
Heavy Duty GLXS	56
ditto Stainless Steel GLRS	57

ditto Stainless Steel GLRS..R	58
Maintenance Free GLXSW	59
ditto Stainless Steel GLRSW	60
ditto GLRSW..R	61
ditto GLRSW..RR	62
ditto GLRSW..RR.316	63
Heavy Duty GXS	64
ditto for Stainless Steel GXS..R	65
Maintenance Free GXSW	66
ditto Stainless Steel GXSW..R	67
ditto Stainless Steel GXSW..RR	68
ditto Stainless Steel GXSW..RR.316	69

Rod Ends Series E

Steel on Steel EI (-2RS) / EA 50 (-2RS)	72
Maintenance Free	
EI..D (-2RS) / EA..D (2RS)	74
ditto Stainless Steel	
EI..D-NIRO (-2RSF) / EA..D-NIRO (-2RSF)	76

Spherical Plain Bearings Series E

Maintenance Free GE..EC (2RS)	70
ditto Stainless Steel GE..EC-NIRO (-2RSF)	71
Steel on Steel GE..E (-2RS)	78
Steel on Steel GE..HO-2RS	79
Inch-sized version GE..ZO (-2RS)	80

Spherical Plain Bearings Series W

Steel on Steel GE..LO	82
---------------------------------	----

Spherical Plain Bearings Series G

Steel on Steel GE..FO (-2RS)	83
Maintenance Free GE..FW (-2RS)	84
ditto Stainless Steel GE..FW-NIRO (-2RS)	85

Angular Contact Spherical Plain Bearings

Steel on Steel GE..SX	86
Maintenance Free GE..SW	87

Contents

Spherical Plain Thrust Bearings

Steel on Steel GE..AX	88
Maintenance Free GE..AW	89

Rod Ends - Hydraulic

with Locking Device FPR..S	90
ditto for Pneumatic Cylinder FPR..CE	91
short thread FPR..N	92
ditto with Locking Device FPR..U	93
Heavy Duty with Locking Device FMA..D	94
with Weld-on Surface FS..C	95
with Weld-on Surface FS..N	96

Angle Joints

Angle Joints to DIN 71802	97
-------------------------------------	----

Fork Heads

Fork Heads to DIN 71751 and DIN 71752	98
---	----

Rubber Seals

Rubber Protector Cap RERS	99
Washer Seals RELS	99

Jam Nuts

Jam Nuts to DIN 934 / ISO 4032	100
Jam Nuts to DIN 439 / 936	100

Specials

Precision Parts Martin Höhn GmbH	101
Inquiry Template Special Parts	102
Notes	103
Notes	104
Custom-Made Products	105

How you can find us	U4
-------------------------------	----

Catalogue, Edition 2018.1

Every care has been taken to ensure the accuracy of the information in this catalogue. However, no liability can be accepted for any errors or omissions. Due to continuing technical advances, we reserve the right to alter our products without notice. Our sales and delivery terms and conditions in the respective valid version, shall apply exclusively for deliveries and other services in commercial business transactions.

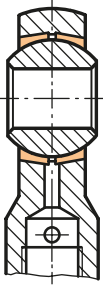
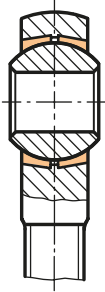
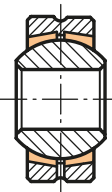
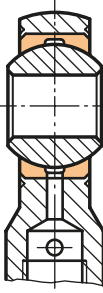
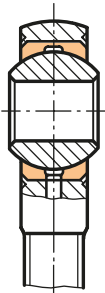
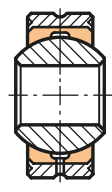
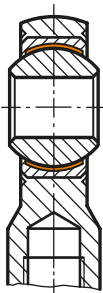
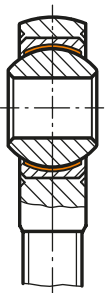
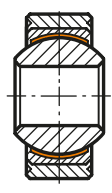
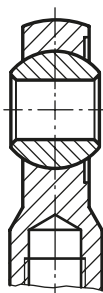
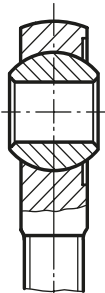
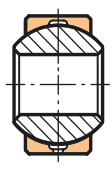
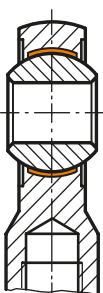
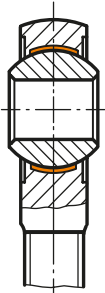
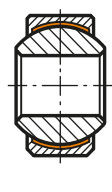

Production Range Series K

Rod Ends DIN ISO 12240-4 Series K Female Thread			Rod Ends DIN ISO 12240-4 Series K Male Thread			Spherical Plain Bearings DIN ISO 12240-1 Series K with / without outer ring		
GI..	Requiring maintenance		GA..	Requiring maintenance		GL..	Requiring maintenance	
GIS.. GIXS.. GIRS.. GIRS..R	Heavy Duty, Requiring maintenance		GAS.. GAXS.. GARS.. GARS..R	Heavy Duty, Requiring maintenance		GLXS.. GLRS.. GLRS..R	Standard-/ Stainless Steel, Maintenance free	
GISW.. GIXSW.. GIRSW.. GIRSW..R GIRSW..RR GIRSW..RR.316 GIRSW..NIRO	Standard-/ Stainless Steel, Maintenance free		GASW.. GAXSW.. GARSW.. GARSW..R GARSW..RR GARSW..RR.316 GARSW..NIRO	Standard-/ Stainless Steel, Maintenance free		GLXSW.. GLRSW.. GLRSW..R GLRSW..RR GLRSW..RR.316	Standard-/ Stainless Steel, Maintenance free	
GIO..	Steel on Steel		GAO..	Steel on Steel		GXS.. GXS..R	Standard-/ Stainless Steel, Maintenance free	
GIOW..	Maintenance free		GAOW..	Maintenance free		GXSW.. GXSW..R GXSW..RR GXSW..RR.316	Standard-/ Stainless Steel, Maintenance free	



Production Range Series E

Rod Ends DIN ISO 12240-4 Series E Female Thread		Rod Ends DIN ISO 12240-4 Series E Male Thread		Spherical Plain Bearings DIN ISO 12240-1 Series E				
EI.. EI..-2RS	Steel on Steel		EA.. EA..-2RS	Steel on Steel		GE..E GE..E-2RS GE..ZO GE..ZO-2RS	Steel on Steel	
EI..D EI..D-2RS	Maintenance free		EA..D EA..D-2RS	Maintenance free		GE..EC GE..EC-2RS	Maintenance free	
EI..D-NIRO EI..D-NIRO-2RS	Stainless Steel		EA..D-NIRO EA..D-NIRO-2RS	Stainless Steel		GE..EC-NIRO GE..EC-NIRO-2RS	Stainless Steel	



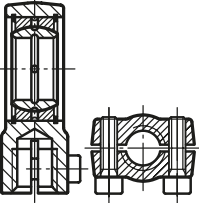
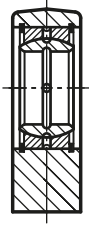
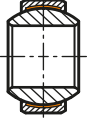
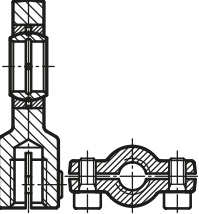
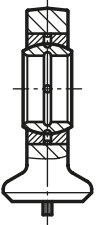
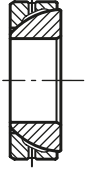
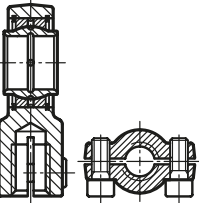
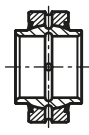
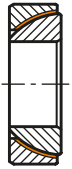
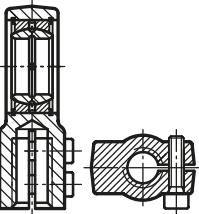
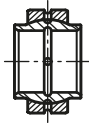
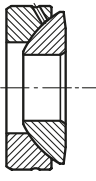
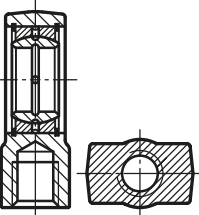
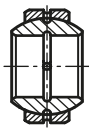

Rod Ends

Production Range

Hydraulic Rod Ends Steel on Steel		Hydraulic Rod Ends + Spherical Plain Bearings Steel on Steel		Spherical Plain Bearings				
FPR..U	Rod End with Locking Device Bearing with Snap Ring		FS..N	Rectangular Weld-on Surface Bearing with Snap Ring		GE..FW (-2RS) GE..FW-NIRO (-2RS)	Maintenance free, Heavy Duty, higher Pivoting Angle	
FPR..S	Rod End with Locking Device Bearing fixed through caulking		FS..C	Circular Weld-on Surface Bearing fixed through caulking		GE..SX	Steel on Steel Angular Contact Bearing	
FPR..CE	Rod End with Locking Device Bearing with Snap Ring		GE..HO-2RS	Steel on Steel Ball with Shoulder		GE..SW	Maintenance free Angular Contact Bearing	
FMA..D	Rod End with Locking Device Bearing with Snap Ring		GE..LO	Steel on Steel Ball with Shoulder		GE..AX	Steel on Steel Thrust Bearing	
FPR..N	Rod End with shorter thread Bearing with Snap Ring		GE..FO (-2RS)	Steel on Steel, Heavy Duty, higher Pivoting angle		GE..AW	Maintenance free Thrust Bearing	

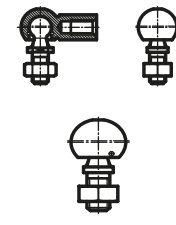
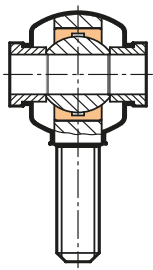
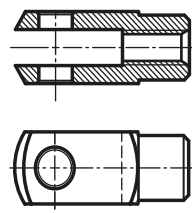
Production Range

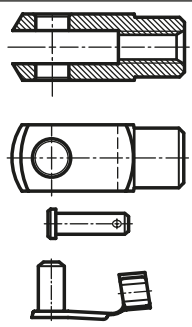
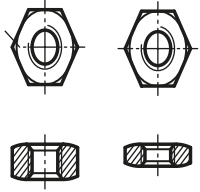
Angle Joints to DIN 71802 Fork Head to DIN 71752		Rubber Seals Locking Nuts to DIN 934 / 439			
Form C../CS..	Angle Joints to DIN 71802		RERS	Rubber Protector Caps made from Neoprene	
G..x..	Fork Head to DIN 71752		RELS	Washer Seals Rubber Seals with stainless steel washer rings	
with ES-Bolt clevis spring pin	Fork Head to DIN 71751		KMR.. KML..	Locking Nuts with right hand or left hand threads	



Angle Joints

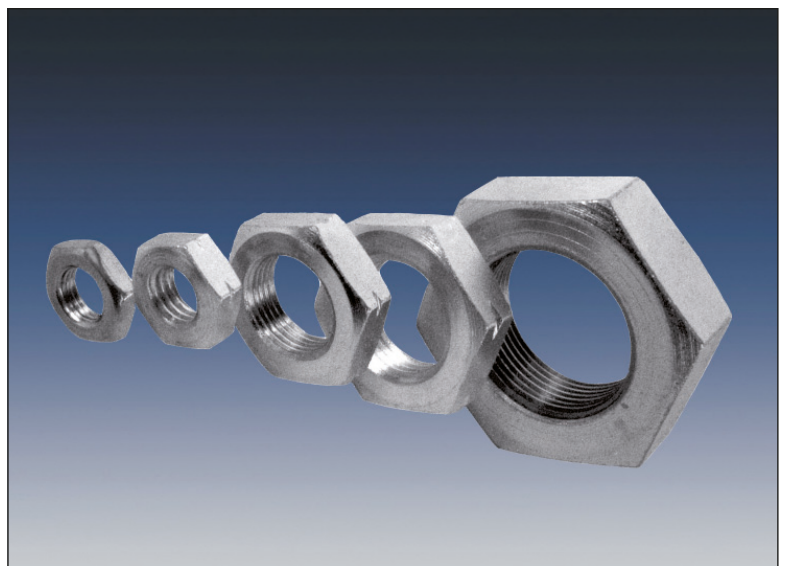

Jam nuts

Production Range



Spherical Plain Bearings

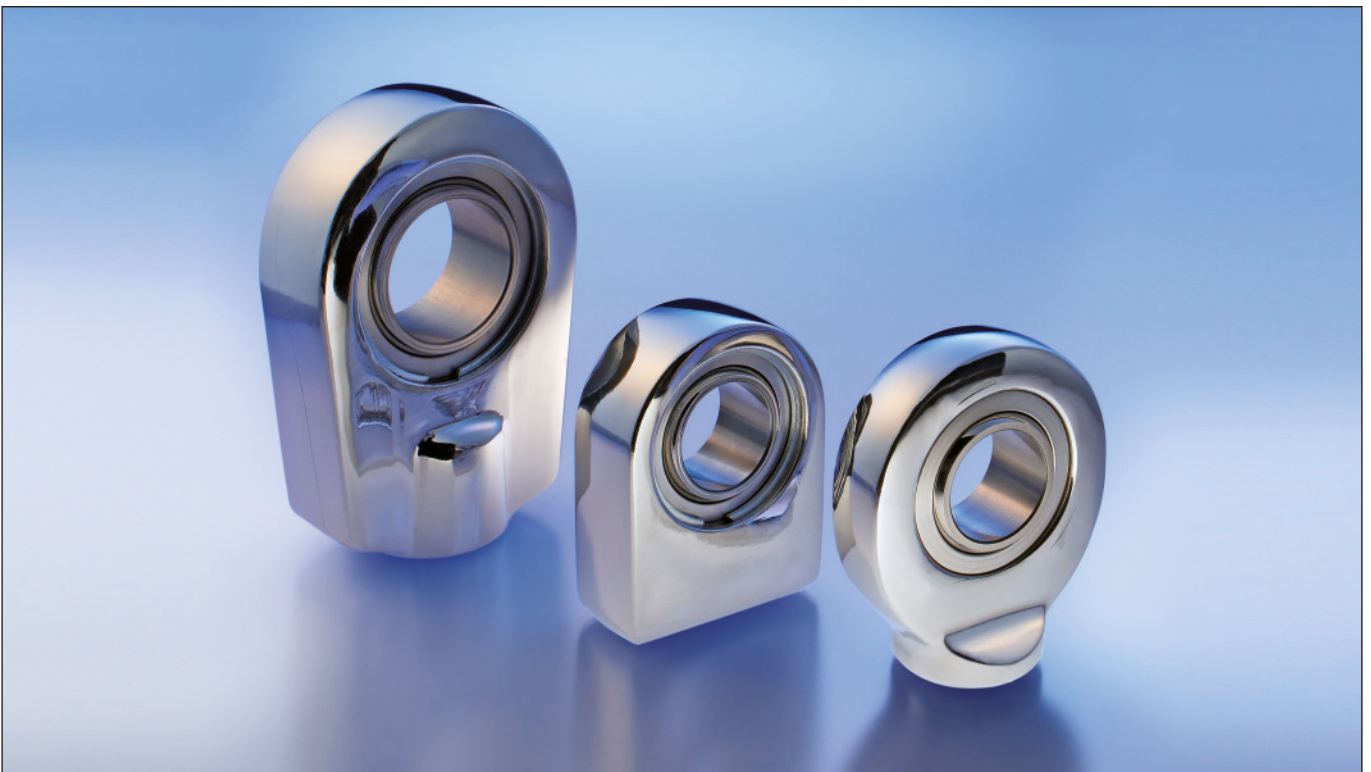

Hydraulic Rod Ends

Special Applications



railway vehicles



conveyors



loading cranes



construction machinery



scissors lift



shipbuilding

Custom-made products

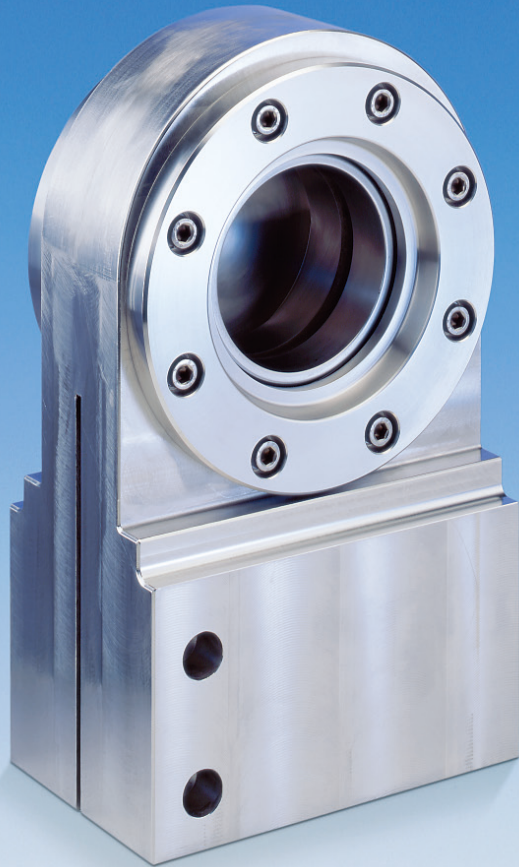

Hydraulic Rod End designed and intended for marine, harbor and river engineering or lock gates. Completely stainless steel to customer design with maintenance free or regreasable Spherical Plain Bearing. Design and development according to customer requirements.

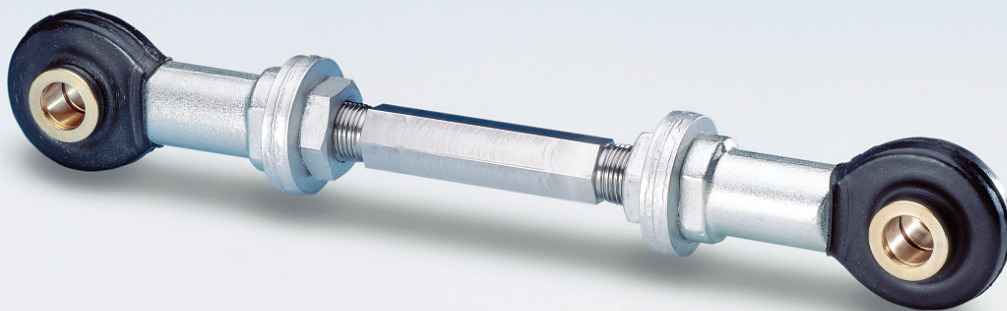

Connecting rod for highest pressure and tension loads, employed in automotive applications. These parts are supplied completely mounted with required axial distance and torque.

FLURO® Motor Sport Series

FLURO® has developed a series of Rod Ends and Spherical Plain Bearings, which have zero tolerance through preloaded bearing, for Motor Sport applications.

**Exclusive
Motor Sport Catalogue
on request !**

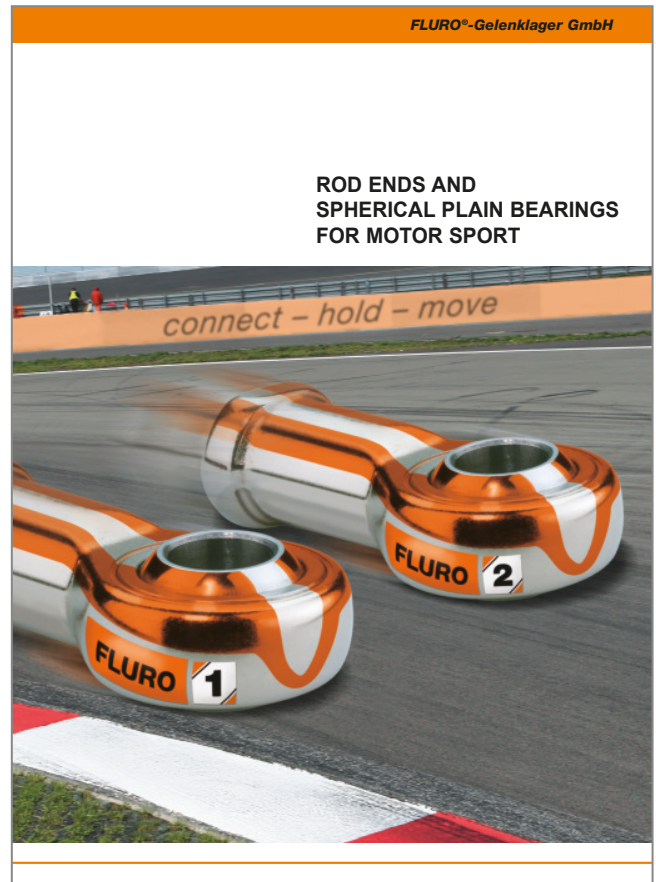

For Rod Ends and Spherical Plain Bearings for extreme demands the latest development **FLUROGLIDE®**, a special developed coating, which is used for Rod Ends and Spherical Plain Bearings with highest demands, provides a solution.

**Please ask for our
exclusive
FLUROGLIDE® catalogue**

Ordering Details

On pages 5 to 10 we have given full details of our standard range of products. Additional notes to make sure details are correct when placing orders are listed below; additions to and deviations from our standard program are listed, as well.

Female Thread:	The letter I is situated in the second place in the reference e.g. GI or EI
Male Thread:	The letter A is situated in the second place in the reference e.g. GA or EA
Left Hand Thread:	The letter L is situated in the third place in the reference e.g. GAL or EAL
Non-Standard Thread:	Bearing reference with additional thread specification e.g. GISW 30, M 27x2
Stainless Steel Ball:	The letter R will be added after size reference e.g. GIRSW 10 R , GXSW 10 R , stainless version (stainless type see pages 32, 40, 58, 61, 65, 67)
Completely Stainless (Series K):	The letters RR will be added after size reference e.g. GARSW 16 RR , GXSW 16 RR (all items in stainless steel)
Completely Stainless (Series E):	The letters NIRO will be added after size reference e.g. GE 10 EC- NIRO or EI 16 D- NIRO
Ball Hard Chrome Plated:	ICR will be added after size reference e.g. GASW 10 ICR
Seal:	-2RS will be added after size reference e.g. GISW 10- 2RS (see pages 52)
Threaded Bolt:	BO will be added after size reference e.g. GISW 10 BO (for right angle use, see page 53)
Nickel Plated Housing:	NI will be added after size reference e.g. GISW 14 NI (improved corrosion resistance for the housing) for series on pages 26 to 29, 34 to 37
Special Grease Nipples:	SN will be added after size reference e.g. GAS 16 SN DIN 71412 H1/A M6x1 (exact name of grease nipple has to be specified)
Left Hand Thread for Hydraulic Rod Ends:	The letter L will be added at the third place replacing the letter R e.g. FPL..N , except for series FMA..D = FMAL..D

For sizes deviating from the standard or for specials, please send us your drawing or sketch – see template on page 102.

The maintenance instructions, selection criteria, tolerances and calculations as shown in the following technical section are intended to be an important guideline for the choice of the correct bearing to suit the particular application of our Rod Ends and Spherical Plain Bearings.

Thread, Pivoting Angle

Threads

Manufactured to standard metric ISO DIN 13 threads. To increase the stability for all standard Rod Ends with male threads, the threads are rolled.

Because of the process procedure of zinc plating, it can not be guaranteed that the zinc layer will reach completely into the thread bore of the female rod ends with its complete zinc layer thickness.

Maximum Pivoting Angle

The permissible maximum Pivoting Angle (see picture 3, page 19) ranges between 6° and 35° depending on the series and constructional design.

The Maximum Pivoting Angle you will find in the product data sheets of series K and series E. The indicated Maximum Pivoting Angles are guide values related to situation 2. Other constructional designs and its calculation examples for the Maximum Pivoting Angle α are indicated in situations 1 and 3.

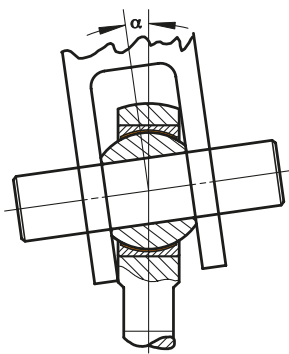

Situation 1

$$\alpha = \sin^{-1} \frac{B}{A} - \sin^{-1} \frac{M}{A}$$

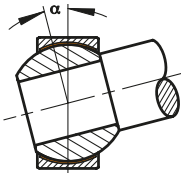

Situation 2

$$\alpha = \sin^{-1} \frac{B}{dK} - \sin^{-1} \frac{M}{dK}$$

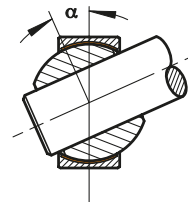

Situation 3

$$\alpha = \cos^{-1} \frac{D}{dK} - \sin^{-1} \frac{M}{dK}$$

A = Outside diameter Rod End/Spherical Plain Bearing

B = Width Ball

dK = diameter Ball

M = Width Rod End/Spherical Plain Bearing

D = diameter Bore Ball

Fit, Installation

Recommended fits for the housing's bore to incorporate Spherical Plain Bearings

		Design	Steel Housing Series K	Light Alloy Housing Series K	Steel Housing Series E / G / W	Light Alloy Housing Series E / G / W
Load	normal	maintenance free	K7	M7	K7	M7
		regreasable	J7/H7	K7	K7	M7
	high	maintenance free	M7	N7	M7	N7
		regreasable	K7	M7	M7	N7

The outside diameter of the Spherical Plain Bearings, Series K is tolerated to h6. For Series E, please refer to each individual product page.

Recommended fit for the shaft

		Design	Series K	Series E GE..E (-2RS) GE..EC (-2RS) GE..EC-Niro GE..HO-2RS	Series G GE..FO (-2RS) GE..FW (-2RS)	Series W GE..LO
Load	normal		h6	g6	g6	h6
	high		k6	j6/h6	j6/h6	j6

Installation instructions:

Attention: No tolerance or play can be allowed for the shaft when incorporated in the Ball or the Outer Ring when incorporated in a housing. Through this it is guaranteed that the glide movement arises on the nodular gliding surface only.

When mounting extra precaution has to be taken that the press force does not damage the bearing. The press force should not be initiated via the Ball itself. Through cooling of the bearing and heating of the housing the necessary press force will be reduced.

Axial locking of Spherical Plain Bearings:

When under high static or dynamic axial load, vibration, impacting load changes or high pivoting angles Spherical Plain Bearings have to be locked axially.

Possible locking methods:

- locking through several puncher points
- caulking of bearing on the housing through a flanging groove
- with locking snap rings
- clamped with bushings on the facing surface of the Insert

Internal Clearance

Internal Clearance is defined as the measure, which can be moved of the radial movement of the ball in the housing or outer ring from a limit position to the opposing. Internal Clearance is measured at room temperature. The axial freedom of movement corresponds approximately to coefficient 3 of the internal clearance.

Series K Type	Size	Radial Internal Clearance in mm (min./max.)
GI/GA; GIS/GAS; GIXS/GAXS; GIRS/GARS (..R)	02 - 10 12 - 20 22 - 40	0,005 - 0,035 0,010 - 0,040 0,010 - 0,050
GISW/GASW; GIXSW/GAXSW; GIRSW/GARSW (..R / ..RR / ..RR.316 / NIRO)	05 - 10 12 - 18 20 - 25 30 - 40	0,005 - 0,030 0,005 - 0,035 0,005 - 0,045 0,005 - 0,055
GLOW/GAOW	04 - 10 12 - 20	0,005 - 0,040 0,005 - 0,050
GIO/GAO	05 - 10 12 - 20	0,010 - 0,050 0,010 - 0,060
GL; GLXS; GLRS (..R); GXS (..R)	02 - 10 12 - 18 20 - 25 30 - 40 40 - 50	0,005 - 0,040 0,005 - 0,050 0,010 - 0,060 0,010 - 0,075 0,015 - 0,095
GLXSW; GXSW (..R / ..RR / ..RR.316) GLRSW (..R / ..RR / ..RR.316)	03 - 10 12 - 18 20 - 25 30 - 40 40 - 50	0,005 - 0,035 0,005 - 0,040 0,005 - 0,050 0,010 - 0,060 0,010 - 0,075

Series E Type	Size	Radial Internal Clearance in mm (min./max.)
EI/EA	06 - 12 15 - 20 25 - 35 40 - 60 70 - 80	0,015 - 0,050 0,020 - 0,065 0,030 - 0,085 0,035 - 0,100 0,045 - 0,120
EI..D/EA..D (-2RS) EI..D-NIRO (-2RS) EA..D-NIRO (-2RS)	06 - 12 15 - 20 25 - 35 40 - 60 70 - 80	0,000 - 0,030 0,000 - 0,040 0,000 - 0,050 0,000 - 0,055 0,000 - 0,060
GE..EC-NIRO (-2RS)	06 - 12 15 - 20 25 - 35 40 - 60 70 - 90 100 - 120 140 - 160	0,000 - 0,032 0,000 - 0,040 0,000 - 0,050 0,000 - 0,060 0,000 - 0,072 0,000 - 0,085 0,000 - 0,100

Series E, G, W Type	Size	Radial Internal Clearance in mm (min./max.)
GE..E (-2RS) GE..HO-2RS GE..LO	04 - 12 15 - 20 25 - 35 40 - 60 70 - 90 100 - 140 160 - 240 260 - 300 320 - 320	0,032 - 0,068 0,040 - 0,082 0,050 - 0,100 0,060 - 0,120 0,072 - 0,142 0,085 - 0,165 0,100 - 0,192 0,110 - 0,214 0,135 - 0,261
GE..EC (-2RS)	04 - 20 25 - 35 40 - 60 70 - 90 100 - 140 160 - 180 200 - 300	0,000 - 0,040 0,000 - 0,050 0,000 - 0,060 0,000 - 0,072 0,050 - 0,130 0,050 - 0,140 0,080 - 0,190
GE..FO (-2RS)	04 - 10 12 - 17 20 - 30 35 - 50 60 - 80 90 - 120 140 - 160 180 - 220 240 - 280	0,032 - 0,068 0,040 - 0,082 0,050 - 0,100 0,060 - 0,120 0,072 - 0,142 0,085 - 0,165 0,100 - 0,192 0,100 - 0,192 0,110 - 0,214
GE..FW (-2RS) GE..FW-NIRO (-2RS)	04 - 30 35 - 50 60 - 80 90 - 120 140 - 160 260 - 280	0,000 - 0,050 0,000 - 0,060 0,000 - 0,072 0,050 - 0,130 0,050 - 0,140 0,080 - 0,190

Series Hydraulic	Size	Radial Internal Clearance in mm (min./max.)
FPR..S FPR..CE FPR..N FPR..U FMA..D FS..C FS..N	10 - 12 15 - 20 25 - 35 40 - 60 63 - 90 100 - 125 160 - 200	0,023 - 0,068 0,030 - 0,082 0,037 - 0,100 0,043 - 0,120 0,055 - 0,142 0,065 - 0,165 0,065 - 0,192

For special applications Rod Ends and Spherical Plain Bearings are manufactured with smaller or higher internal clearance. **C2** is smaller (tighter fit) than given above and **C3** is higher (increased internal clearance) than given above, also as **C1 / C0** clearance with torque available.

Lubrication

Maintenance Free Rod Ends and Spherical Plain Bearings must not be lubricated. The ball revolves on a PTFE liner incorporated in the housing.

Rod Ends with Steel running on special Brass, or with Steel running on Bronze, and Steel on Steel require regular lubrication. The first time lubrication has to be carried out when the part is mounted. The regreasing interval depends on the impacting influences, such as ambient conditions (temperature, dust, etc) and the mechanical impacts given through the application (surface pressure, number of alternation stress, pivoting angle, gliding speed, etc.).

For the lubrication of Spherical Plain Bearings up to a temperature of +110° Celsius, (+230° Fahrenheit) white paste, such as Gleitmo 805k, is recommended. For higher temperatures from +110° to +220° Celsius, (+230° to +428° Fahrenheit) we recommend high temperature grease, such as Notropeen EHT2.

Regreaseable Rod Ends Series K are lubricated by means of a grease nipple to DIN 3405.

For Steel on Steel Rod Ends Series E from size 20 hydraulic grease nipples to DIN 71412 are incorporated.

Temperature range

FLURO® Rod Ends and Spherical Plain Bearings can be operated within the operating temperatures listed below:

Mating surface	Temperature Celsius	Temperature Fahrenheit
Steel/Special Brass	- 50° to +200°	- 58° to +392°
Steel/Bronze	- 50° to +250°	- 58° to +480°
Steel/PTFE liner	-150° to +250°	-238° to +480°
Steel/PTFE Glass fibre liner	- 75° to +150°	-103° to +302°
Steel/Steel	- 50° to +200°	-103° to +392°
GE..EC, FW, AW, SW	- 50° to +150°	- 58° to +302°
GE..-2RS	- 30° to +130°	- 22° to +266°
GE..EC-NIRO	-150° to +250°	-238° to +480°
PTFE/hard chrome	- 50° to +150°	- 58° to +302°

From a temperature range from above +250° C our heavy duty Spherical Plain Bearings are used.

Material Conversion Table

Material	DIN German	France	Italy	Sweden	UK	USA
1.0402	C22	XC25	C21	1450	070M20	M1023
1.0503	C45	1C45	C45	1650	080M46	Aisi 1045
2.1030	CuSn8					
2.0561	CuZn40Al1					
1.3505	100Cr6	100Cr6	100Cr6	2258	2S135	Aisi 52100
1.7225	42CrMo4	42CrMo4	42CrMo4	2244	708M40	Aisi 4140
1.0715	11SMn30+C	S250	CF9SMn28	1912	230M07	Aisi 1213
1.4006	X10Cr13	Z10C13	X12Cn13	2302	410C21	Aisi 410
1.4034	X46Cr13	Z44C14	X40Cr14		420S45	Aisi 420C
1.4057	X20CrNi172	Z15CN16-02	X16CrNi16	2321	431S29	Aisi 431
1.4112	X90CrMoV18					Aisi 440B
1.4125	X105CrMo17	Z100CD17				Aisi 440C
1.4301	X5CrNi1810	Z4CN19-10FF	X5CrNi1810	2332	304S17	Aisi 304
1.4305	X10CrNiS189	Z8CNF18-09	X10CrNiS1809	2346	303S22	Aisi 303
1.4401	X5CrNiMo17122	Z7CND17-12-02	X5CrNiMo1712	2347	316S17	Aisi 316
1.4542	X5CrNiCuNb174	Z7CNU15-05	—————	—————	—————	Aisi 630 (174Ph)
1.4571	X6CrNiMoTi17-12-2	Z6CNDT17-12	X6CrNiMoTi1712	2350	320S18	Aisi 316Ti

Bearing Load ratings

Bearing Load ratings are bearing specific data, derived from the characteristics of the materials used. They are used when selecting Spherical Plain Bearings or Rod Ends for a particular load, but may have to be reduced in adverse operating conditions.

Static Load ratings C_o [kN]

C_o indicates the maximum permissible static load which a Rod End at its weakest cross section can withstand without developing permanent distortion. The C_o values listed in the tables of this brochure have been calculated by using the appropriate material specifications and have been tested on a number of Rod Ends during tensile tests carried out at ambient temperature. 80% of the yield strength resulting from the tests have been used so that a safety factor of 1.25 is included. The static load C_o is also used for establishing the maximum axial load which is limited by an additional bending stress principally due to the method of fastening of the insert. Following are maximum axial values (deformation) which have been established by pressure testing:

$$(1) \quad F_a = F_{a, \max} = a \cdot C_o \quad [\text{kN}]$$

- $a = \approx 0,4$ for GI/GA + GIO/GAO + GXO
- $a = \approx 0,2$ for GXSW, GXS, GL mounted in a FLURO® rod end housing
- $a = \approx 0,1$ for EI/EA, EI/EA..D-NIRO

For Spherical Plain Bearings C_o indicates the radial load, which does not deform the mating surface permanently. Precondition is the stable configuration of the housing.

Dynamic Load ratings C [kN]

This rating is used to establish the working life of Spherical Plain Bearings or Rod Ends when under dynamic load conditions. That is to say when they oscillate, rotate or pivot under load. The values listed in the table result from multiplying the maximum surface pressure p_{\max} admissible in gliding movements by the projected bearing surface. A_{proj} , whereby a specific load rating is established for each type of Rod End. The established standard values for maximum surface load for various combinations of antio friction material have been listed in table 1 which allows for movement when oscillation. Information: Depending on the material strength of the Rod End housing (eg. pages 34 and 35) the static load might be lower than the dynamic load. For this the procedure stated on page 23 has to be observed.

For applications with threshold or/and alternating loads, the dynamic load rating of the rod end housing needs to be considered separately.

p_{\max} [N/mm ²]	St/Ms	St/Bz	St/St soft	St/St hard	St/TBz	St/TNy
	50	50	50	100	150	50

Table 1: Maximum surface pressure

Abbreviations: St = Steel, Ms = Brass, Bz = Bronze, TBz = Woven Bronze Fabric, TNy = Woven Nylon

Forces affecting a Bearing

The loads affecting a Spherical Plain Bearing can vary. They can be:

- intermittent, constant or variable (illustration 1)
- static or dynamic

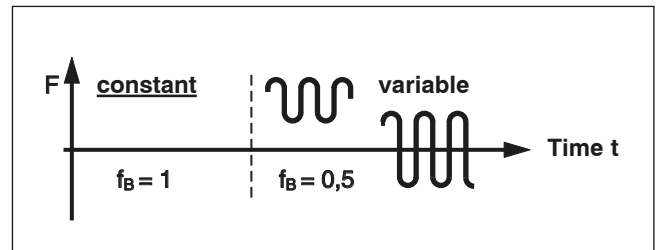

Picture 1: Load factors - check f_B

Attention: For Rod Ends with male thread factors choose $f_B = 0,35$ when load changeable.

Forces when under static load

Radial only (F_r) or radial and axial (F_a) forces arise and there is no movement between the ball and the insert (Picture 2).

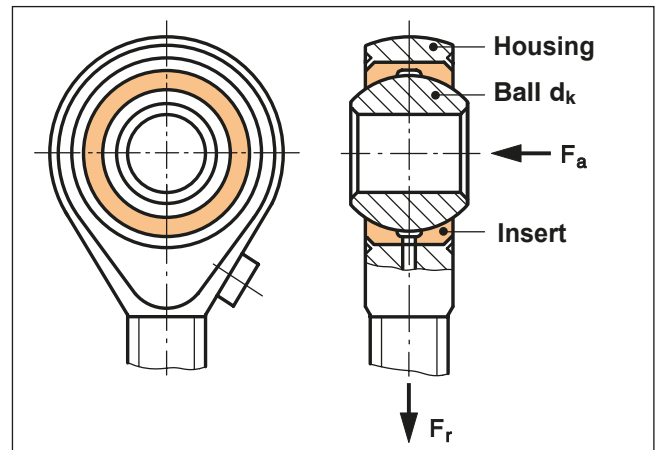

Picture 2: Radial and axial forces

Forces when under dynamic load

Radial or radial and axial forces arise, when the Ball pivots at angle α , oscillates at angle β or rotates relative to the Insert.

Technical Information

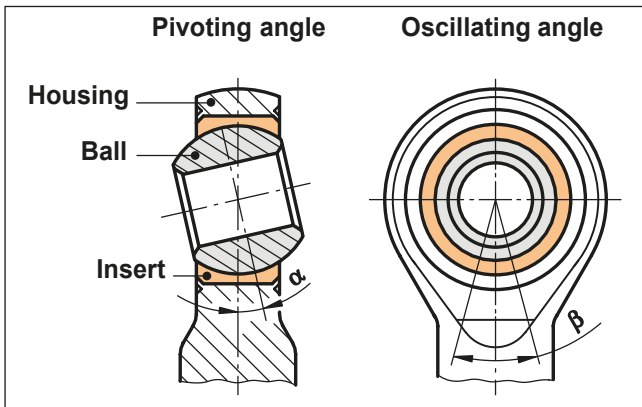

Picture 3: Pivoting and oscillating angle

In the case of a **constant load** F_r , F_a a dynamically equivalent bearing load F_e can be established in accordance with formula (2).

$$(2) \quad F_e = F_r + Y \cdot F_a \quad [\text{kN}]$$

therefore: $F_e \leq F_{r, \max}$ according to formula (6);
 $F_a \leq F_{a, \max}$ (6a)

The axial factor Y in table 2 is dependent on the load ratio.

Load ratio $F_a : F_r$	0,1	0,2	0,3	0,4	0,5
Axial factor Y	0,8	1	1,5	2,5	3

Table 2: Axial factor Y

In the case of a **variable load** (picture 4), formula (4) can be used to calculate a mean dynamic bearing load F_m from the individual load levels F_i and the appropriate time factor t_i .

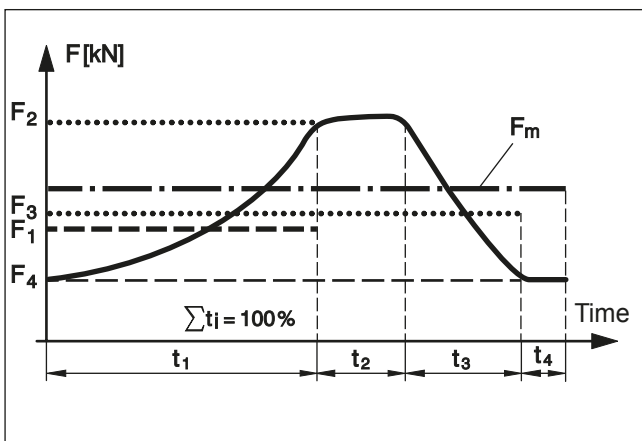

Picture 4: Variable load against time

$$(3) \quad F_m = 0,1 \sqrt{F_1^2 \cdot t_1 + F_2^2 \cdot t_2 + \dots} \quad [\text{kN}]$$

Force F [kN] : time component t [%]
 therefore the following must be valid: $F_{i, \max} \leq F_{r, \max}$ according to (6)

In case of an additional axial load the equivalent bearing load is calculated according to formula (4).

$$(4) \quad F_e = F_m + Y \cdot F_a \quad [\text{kN}]$$

Axial factor Y according to table 2
 $F_a \leq F_{a, \max}$ according to (6a)

Selection of the bearing size

The selection is usually made step by step, repeated if necessary, by comparing -

1. the load ratio involved with the normal minimum values for that ratio;
2. the forces affecting the bearing and the maximum permitted load of the bearing proposed;
3. the maximum surface pressure and the surface pressure on the proposed bearings;
4. the maximum glide speed and the glide speed involved of the bearing proposed;
5. the specific performance of the bearing involved with the published catalogue limits.

Re 1:

The load ratio (C/F) is a value for a specific use of a bearing according to formula (5).

$$(5) \quad (C/F)_{\text{exist}} \geq (C/F)_{\text{min}}$$

The common minimum values for (C/F) for different antifriction surfaces as listed in table 3, can be used to establish the required dynamic load rating C in accordance with formula (5a) by changing formula (5). By this means a suitable bearing size can be selected from the tables of this catalogue.

$(C/F)_{\text{min}}$	St/Ms	St/Bz	St/St	St/TBz	St/TNy
	2	2	2	1,75	1,5

Table 3: Typical load ratios

$$(5a) \quad C_{\text{reg}} \geq (C/F)_{\text{min}} \cdot F_{\text{exist}} \quad [\text{kN}]$$

Technical Information

Re 2:

When the existing force affecting the bearing is a static load, it can be used as is for a comparison. When it is a dynamic load, it can be calculated by using formula (2), (3) or (4).

When a Rod End is mounted with a locking nut or retransfer with two nuts, the additional tensile stress at the male thread or the connecting rod has to be taken into consideration.

However the static or dynamic load must always be smaller than the maximum permitted load, which is calculated from the static load rating C_o using formula (6). This might have to be further reduced by the load factor f_B (picture 1) and the temperature factor f_T (table 4).

Temperature C	80°	100°	150°	200°	250°
Temperature F	176°	212°	302°	392°	480°
greased	1	1	1	0,8	0,5
maintenance free	1	1	0,8	0,5	0,3

Table 4: Temperature factor f_T

$$(6) \quad F_{r, \max} = C_o \cdot f_B \cdot f_T \quad [\text{kN}]$$

$$(6a) \quad F_{a, \max} = a \cdot F_{r, \max} \quad [\text{kN}]$$

If no bearing size is given in the application the required static load rating can be established by changing formula (6) and a Rod End can be selected from the tables accordingly.

$$(7) \quad C_{o, \text{reg}} \geq \frac{F_{\text{exist}}}{f_B \cdot f_T} \quad [\text{kN}]$$

Re 3:

The load on a mating surface can be worked out by using formula (8). It must be less than the standard value for surface load according to the antifriction combination of materials, selected as listed in table (1).

$$(8) \quad p_{\text{exist}} = p_{\max} / (C/F)_{\text{exist}} \quad [\text{N/mm}^2]$$

p_{\max} acc.to table 1, F acc.to formula (2),(3) or (4)

Re 4:

The existing average glide speed v_m is calculated according to formula (9) using the frequency of rotation of the crank K and the glide distance of the Spherical Plain Bearing G. (At one rotation of K it corresponds to the double arc b between the centres 1 and 2 in Picture 5 and thus to the double maximum oscillating angle β).

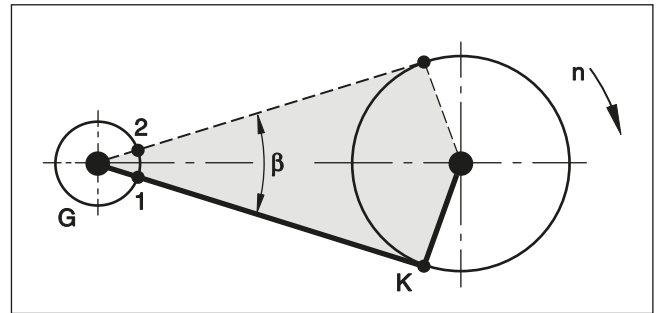

Picture 5: Oscillating angle β relative to crank rotation

$$(9) \quad v_{m, \text{exist}} = 2 \cdot b \cdot f = \frac{d_k \cdot \beta \cdot f}{1000 \cdot 57,3 \cdot 60} \quad [\text{m/s}]$$

Diameter of ball d_k [mm] and f [1/min]

In case where the bearing rotates fully β needs to be substituted by 180° . The slip speed has to be less than the speed permissible listed in table 5.

V_{\max} [m/s]	Oscillation	Revolution
Steel/Steel	0,15	0,10
Steel/Bronze (Brass)	0,25	1,00
Maintenance free	0,25	0,35 <small>short temporary intervals only</small>

Table 5: Maximum slip speed

Re 5:

The product $p \cdot v$ can be defined as a specific bearing performance P_L (see formula 10). Thus, an estimated value for the heat build-up per mm^2 of the Spherical Plain Bearing surface is available, mainly dependent on the antifriction material combination, the lubrication/cooling applied and the surface pressure and glide speed. By increasing temperature the allowable surface pressure of maintenance free bearings is decreasing (picture 1 and 4).

$$(10) \quad P_{L, \text{exist}} = p_{\text{exist}} \cdot v_{\text{exist}} \quad \left[\frac{\text{N} \cdot \text{m}}{\text{mm}^2 \cdot \text{s}} = \frac{\text{W}}{\text{mm}^2} \right]$$

Slip speed v according to (9)

Surface pressure p according to (8)

After the selection of the bearing the following is valid:

$$P_{L, \text{exist}} \leq P_{L, \max}$$

$P_{L, \max}$ [W/mm ²]	Steel/Bz, (Brass), (Steel)	Maintenance free
	0,5	1,3

Table 6: Maximum specific bearing performance

Technical Information

Bearing life calculations

In the case of a static load it is not necessary to calculate the working life. The permissible limit set at 80% of the breaking point allows the forces to act indefinitely.

In the case of dynamic loads calculating the bearing life is problematic. There are many, sometimes interdependent influences, that cannot always be taken into consideration. Therefore, a calculation of the bearing life can only be approximate. As an approximation the bearing has an increased life proportional to its load rating and also when used at a moderate speed.

Additional influences can be taken into account by making use of the factors in formula (11).

$$(11) \quad G_h \approx 3 \cdot f_L \cdot f_T \cdot f_G \cdot f_v \left(\frac{C/F}{v_m} \right)_{\text{exist}} \quad [\text{h}]$$

- f_L = Direction of load to table 7
- f_T = Temperature factor to table 4
- f_G = Glide factor to table 8
- f_v = Relubrication factor to table 9
- C/F = Load ratio
- v_m = Mean glide speed [m/s]

The direction of load factor indicates whether the direction of load is uni-directional, constant, variable or oscillating.

Direction of load	Steel/Steel	Steel/Bz	Steel/PTFE
unidirectional	1	1	1
varying	2,5	2	1

Table 7: Directional load factors f_L

The slip factor f_G takes into account the materials used on the mating surfaces of a bearing. As a result the only distinction that can be made is between being maintenance free (not lubricated) and where lubrication is necessary.

$(C/F)_{\text{exist}}$	1,5	2	3	4	6	8	10	15	20
maint. free	1,5	2,0	2,5	3,0	3,5	4,0	4,3	4,7	5,0
greased	1,1	1,2	1,3	1,4	1,6	1,8	2,1	2,4	2,5

Table 8: Glide factors f_G

The relubrication factor f_v takes into account the extension of the bearing life G_h when regularly lubricated. The greater the surface pressure p_{exist} the more often the bearing has to be relubricated. If the bearing is only lubricated on commissioning as in the case of bearings with PTFE liners, $f_v = 1$ has been inserted.

p_{exist} [N/mm ²]	5	10	25	40
Regular regreasing regreaseable bearing	6	4	3	2
Initial greasing + PTFE	1	1	1	1

Table 9: Relubrication factors f_v

Lubrication intervals are dependent on load conditions and therefore have to be set by the operator.

Calculation Examples

1. Example:

In a paper machine used for manufacturing writing pads a rod end with female thread is used. The dimensions of the components in the machine require size 16, and the following values are also given:

Variable radial load through $F_r = \pm 2$ kN; No axial load

Max. angle of misalignment $\beta = 20^\circ$; Oscillating interval $f = 150/\text{min.}$; operating temperature $T = +50^\circ$ Celsius, $+122^\circ$ Fahrenheit

Regular lubrication possible

1. Initial selection of Rod End

- a) **Type of Bearing** Rod Ends Series GI, GIS, GIXS, GIRS, GIO can be used when relubricating. However, the following have to be excluded
- GIO, because it cannot be lubricated and only moderate movements are possible.
 - GIRS, a stainless steel type is unnecessary as the working environment is not corrosive. So we can choose from female rod end types GI, GIS, GIXS.

- b) **Size** The required diameter of the ball is 16 mm and the following values for GIS can be ascertained from the brochure on pages 26 and 64.

$$d_k = 28,6 \text{ mm}; C_o = 32,0 \text{ kN}; C = 21,5 \text{ kN}$$

b1) required static load rating C_o [formula 7 + picture 1 + table 4]

$$C_{o, \text{ req}} \geq \frac{F_{\text{ exist}}}{f_B \cdot f_T} = \frac{2}{0,5 \cdot 1} = \underline{\underline{4 \text{ kN}}}$$

b2) required dynamic load rating C [formula 5a + table 3]

$$C_{\text{ req}} \geq (C/F)_{\text{ min}} \cdot F_{\text{ exist}} = 2 \cdot 2 = \underline{\underline{4 \text{ kN}}}$$

Check

$$C_{o, \text{ exist}} = 32,0 \text{ kN} > C_{o, \text{ req}} = 4 \text{ kN}$$

$$C_{\text{ exist}} = 21,5 \text{ kN} > C_{\text{ req}} = 4 \text{ kN}$$

$$F_r = 2 \text{ kN} \leq F_{r, \text{ max}} = C_o \cdot f_B \cdot f_T = 32,0 \cdot 0,5 \cdot 1 = 16,0 \text{ kN}$$

2. Checking the surface pressure [formula 8 + table 1]

$$p_{\text{ exist}} = \frac{p_{\text{ max}}}{(C/F)_{\text{ exist}}} = \frac{50}{21,5/2} = \frac{50}{10,75} = \underline{\underline{4,65 \text{ N/mm}^2}} < p_{\text{ max}} = 50 \text{ N/mm}^2$$

3. Checking the slip speed [formula 9 + table 5]

$$v_{m, \text{ exist}} = \frac{d_k \cdot \beta \cdot f}{1000 \cdot 57,3 \cdot 60} = \frac{28,6 \cdot 20 \cdot 150}{1000 \cdot 57,3 \cdot 60} = \underline{\underline{0,025 \text{ m/s}}} < v_{\text{ max}} = 0,25 \text{ m/s}$$

4. Checking the specific bearing performance [formula 10 + table 6]

$$P_{L, \text{ exist}} = p_{\text{ exist}} \cdot v_{m, \text{ exist}} = 4,65 \cdot 0,025 = \underline{\underline{0,12 \text{ W/mm}^2}} < P_{L, \text{ max}} = 0,5 \text{ W/mm}^2$$

5. Calculation of bearing life [formula 11 + table 7 + 4 + 8 + 9]

$$G_h \approx 3 \cdot f_L \cdot f_T \cdot f_G \cdot f_V \cdot \left(\frac{C/F}{v_{m, \text{ exist}}} \right) = 3 \cdot 2 \cdot 1 \cdot 2,1 \cdot 6 \cdot \frac{10,75}{0,025} = \underline{\underline{32.500 \text{ hrs.}}}$$

6. Final selection

Following steps 1b to 5. - the calculations for rod ends GI 16 and GIXS 16 can be checked. When making a decision on the bearing to use, design, application and price have to be taken into consideration for each type.

Calculation Examples

2. Example:

In a mechanical handling facility multi-directional radial loads are applied to the rod end. These loads are the same as shown in illustration 4, page 19. Four separate loads $F_{r,i}$ with the four appropriate time components have been substituted as shown below:

$F_{r1} = 2 \text{ kN}$, $t_1 = 50\%$; $F_{r2} = 4 \text{ kN}$, $t_2 = 16\%$; $F_{r3} = 2,4 \text{ kN}$, $t_3 = 24\%$; $F_{r4} = 1 \text{ kN}$, $t_4 = 10\%$;

Additionally the rod end is subjected to a constant axial load $F_a = 0,65 \text{ kN}$

Further operating conditions: max. angle $\beta = 30^\circ$; oscillation frequency $f = 60/\text{min.}$; max. temperature 70°C

1. Initial selection of Rod End

a) **Type of bearing** As regular lubrication is not possible due to poor accessibility a maintenance free type must be used. Rod Ends GASW, GAXSW, GARSW, GAOW could be suitable, but the following series have to be ruled out.

- GAOW - these Rod Ends are only suitable for restricted movement.

- GARSW - because the working environment is not corrosive.

This leaves the size of the male thread version of type GASW to be established.

b) **Size** b₀) mean and equivalent bearing load [formula 3 + 4 + table 2]

$$F_m = 0,1 \sqrt{\sum F_i^2 \cdot t_i} = 0,1 \sqrt{2^2 \cdot 50 + 4^2 \cdot 16 + 2,4^2 \cdot 24 + 1^2 \cdot 10} = \underline{\underline{2,46 \text{ kN}}}$$

$$F_e = F_m + Y \cdot F_a = 2,46 + 1,26 \cdot 0,65 = \underline{\underline{3,28 \text{ kN}}} \quad Y = 1,26 \text{ for } F_a/F_m = 0,65/2,46 = 0,26$$

b₁) required static load rating C_o [formula 7 + picture 1 + table 4]

$$C_{o, \text{req}} \geq \frac{F_{\text{exist}, e}}{f_B \cdot f_T} = \frac{3,28}{0,5 \cdot 1} = \underline{\underline{6,56 \text{ kN}}}$$

b₂) required dynamic load rating C [formula 5a + table 3]

$$C_{\text{req}} \geq (C/F)_{\text{min}} \cdot F_{\text{exist}} = 1,75 \cdot 3,28 = \underline{\underline{5,75 \text{ kN}}}$$

c) **Bearing selected GASW 12** with $d_k = 22,2 \text{ mm}$ and $C_o = 23,5 \text{ kN}$ $C = 32,0 \text{ kN}$

Check [formula 6 + 6a]

$$C_{o, \text{exist}} = 23,5 \text{ kN} > C_{o, \text{req}} = 6,56 \text{ kN} \quad F_{r2} = 4,00 \text{ kN} \leq F_{r, \text{max}} = C_o \cdot f_B \cdot f_T = 23,5 \cdot 0,5 \cdot 1 = 11,75 \text{ kN}$$

$$C_{\text{exist}} = 32,0 \text{ kN} > C_{\text{req}} = 5,75 \text{ kN} \quad F_a = 0,65 \text{ kN} \leq F_{a, \text{max}} = a \cdot F_{r, \text{max}} = 0,2 \cdot 11,75 = 2,35 \text{ kN}$$

[a = 0,2 see formula 1]

Note: When selecting the size the dynamic load C_{req} should not exceed the static load $C_{o, \text{exist}}$

2. Checking the surface pressure [formula 8 + table 1]

$$p_{\text{exist}} = \frac{p_{\text{max}}}{(C/F)_{\text{exist}}} = \frac{150}{32,0/3,28} = \frac{150}{9,75} = \underline{\underline{15,38 \text{ N/mm}^2}} < p_{\text{max}} = 150 \text{ N/mm}^2$$

3. Checking the slip speed [formula 9 + table 5]

$$v_{m, \text{exist}} = \frac{d_k \cdot \beta \cdot f}{1000 \cdot 57,3 \cdot 60} = \frac{22,2 \cdot 30 \cdot 60}{1000 \cdot 57,3 \cdot 60} = \underline{\underline{0,011 \text{ m/s}}} < v_{\text{max}} = 0,25 \text{ m/s}$$

4. Checking the specific bearing performance [formula 10 + table 6]

$$P_{L, \text{exist}} = p_{\text{exist}} \cdot v_{m, \text{exist}} = 15,38 \cdot 0,011 = 0,17 \text{ W/mm}^2 < P_{L, \text{max}} = 1,3 \text{ W/mm}^2$$

5. Calculation of bearing life [formula 11 + table 7 + 4 + 8 + 9]

$$G_h \approx 3 \cdot f_L \cdot f_T \cdot f_G \cdot f_v \cdot \left(\frac{C}{F} \right)_{\text{exist}} = 3 \cdot 1 \cdot 1 \cdot 4,2 \cdot 1 \cdot \frac{9,75}{0,011} = \underline{\underline{11.100 \text{ hrs.}}}$$

6. Final selection

Steps 1c to 5 can then be repeated for series GAXSW so that after comparing the required material strength, price etc. of each type, a final decision can be taken.

Rod Ends Series K - Standard

Series GI

Rod End with female thread regreasable through grease nipple in the housing

Especially suited for axial loads

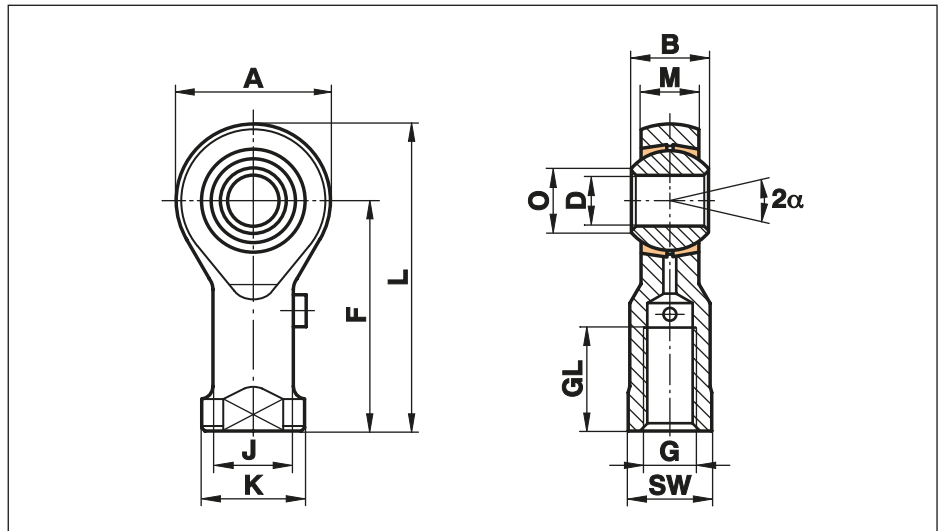

Size (D H7)	B	M	A	F	L	K	J	O	SW	G	GL	Static load C ₀ kN	Dynamic load C kN	Limiting speed rev/min	Maximum Pivoting Angle α (°)	Weight g
5	8	6,00	18	27	36	11	9,0	7,7	9	M 5	10	9,9	2,5	900	13	18
6	9	6,75	20	30	40	13	10,0	8,9	11	M 6	12	11,9	3,2	760	13	27
8	12	9,00	24	36	48	16	12,5	10,4	13	M 8	16	17,1	5,4	620	14	46
10	14	10,50	28	43	57	19	15,0	12,9	17	M 10	20	21,4	7,5	500	13	76
12	16	12,00	32	50	66	22	17,5	15,4	19	M 12	22	27,0	10,0	450	13	115
14	19	13,50	36	57	75	25	20,0	16,8	22	M 14	25	24,5	13,0	360	16	170
16	21	15,00	42	64	85	27	22,0	19,3	22	M 16	28	37,0	16,0	350	15	230
18	23	16,50	46	71	94	31	25,0	21,8	27	M 18x1,5	32	43,0	19,5	320	15	320
20	25	18,00	50	77	102	34	27,5	24,3	32	M 20x1,5	33	49,5	23,5	280	14	415
22	28	20,00	54	84	111	37	30,0	25,8	32	M 22x1,5	37	57,0	29,0	250	15	540
25	31	22,00	60	94	124	42	33,5	29,6	36	M 24x2	42	68,0	35,0	230	15	750

only for short-term revolutions recommended

Materials:

Housing: up to size 12 turned from free-cutting steel to 11SMn30+C galvanised, from size 14 forged from heat-treated steel C22, M1023 galvanised

Insert: Special brass to CuZn38Al1

Ball: Bearing steel to 100Cr6, Aisi 52100, hardened, ground, polished

Cetop connections see page 54.

Rod Ends Series K - Standard

Series GA

Rod End with male thread regreasable through grease nipple in the housing

Especially suited for axial loads

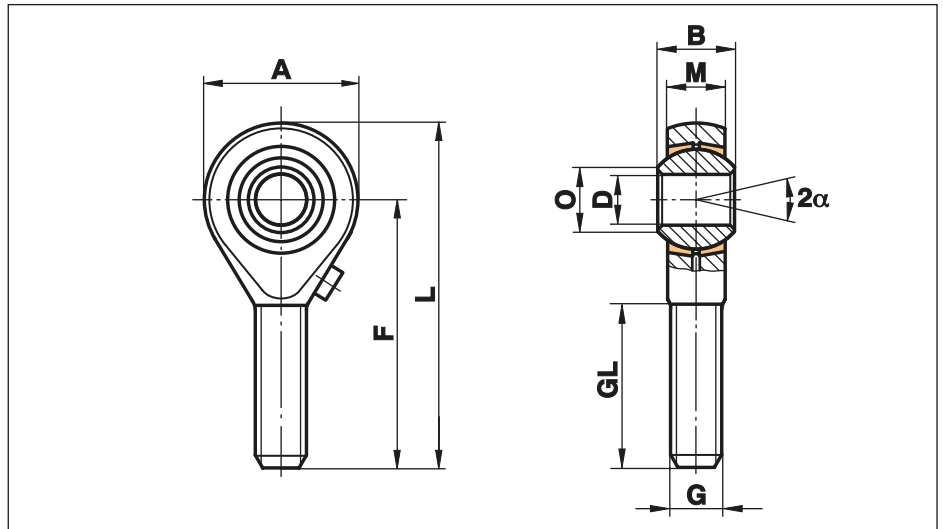

Size (D H7)	B	M	A	F	L	O	G	GL	Static load C ₀ kN	Dynamic load C kN	Limiting speed rev/min	Maximum Pivoting Angle α (°)	Weight g
5 ¹⁾	8	6,00	18	33	42	7,7	M 5	19	4,3	2,5	900	13	13
6	9	6,75	20	36	46	8,9	M 6	21	6,0	3,2	760	13	20
8	12	9,00	24	42	54	10,4	M 8	25	11,0	5,4	620	14	33
10	14	10,50	28	48	62	12,9	M 10	28	17,4	7,5	500	13	56
12	16	12,00	32	54	70	15,4	M 12	32	25,5	10,0	450	13	87
14	19	13,50	36	60	78	16,8	M 14	36	24,5	13,0	360	16	129
16	21	15,00	42	66	87	19,3	M 16	40	36,5	16,0	350	15	189
18	23	16,50	46	72	95	21,8	M 18x1,5	44	43,0	19,5	320	15	267
20	25	18,00	50	78	103	24,3	M 20x1,5	47	49,5	23,5	280	14	348
22	28	20,00	54	84	111	25,8	M 22x1,5	51	57,0	29,0	250	15	443
25	31	22,00	60	94	124	29,6	M 24x2	57	68,0	35,0	230	15	600

only for short-term revolutions recommended

Materials:

Housing: up to size 12 turned from free-cutting steel to 11SMn30+C galvanised, from size 14 forged from heat-treated steel C22, M1023 galvanised

Insert: Special brass to CuZn38Al1

Ball: Bearing steel to 100Cr6, Aisi 52100, hardened, ground, polished

¹⁾ without lubrication hole

Rod Ends Series K - requiring maintenance

Series GIS

Rod End with female thread regreasable through grease nipple in the housing

Especially suited for high speed applications

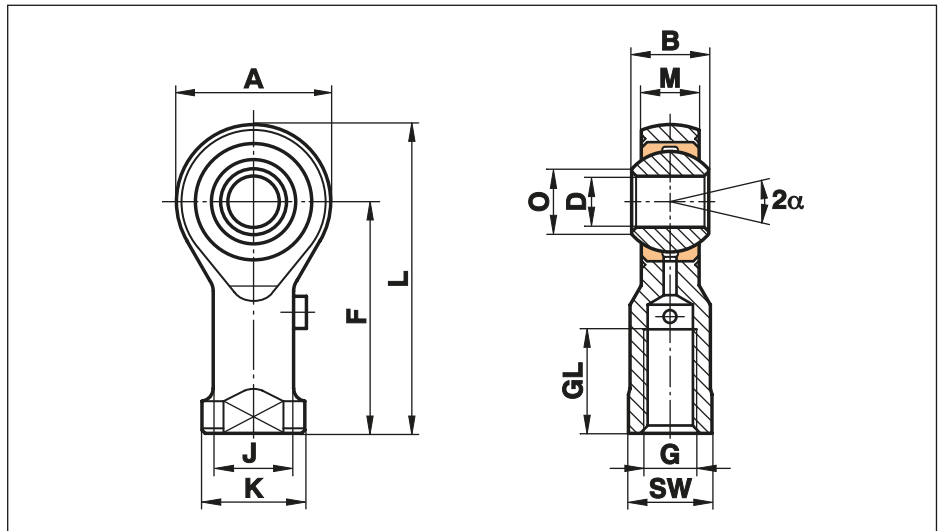

Size (D H7)	B	M	A	F	L	K	J	O	SW	G	GL	Static load C ₀ kN	Dynamic load C kN	Limiting speed rev/min	Maximum Pivoting Angle α (°)	Weight g
2 ¹⁾	4,5	3,60	9	16	20,5	4,5	3,8	2,6	4,0	M 2	7	3,0	1,1		16	3
3 ¹⁾	6,0	4,50	14	21	27,0	6,5	5,0	5,1	5,5	M 3	10	4,1	1,8		14	6
5	8,0	6,00	18	27	36,0	11,0	9,0	7,7	9,0	M 5	10	8,0	3,3	1200	13	18
6	9,0	6,75	20	30	40,0	13,0	10,0	8,9	11,0	M 6	12	8,9	4,3	1500	13	27
8	12,0	9,00	24	36	48,0	16,0	12,5	10,4	13,0	M 8	16	14,1	7,1	1200	14	46
10	14,0	10,50	28	43	57,0	19,0	15,0	12,9	17,0	M 10	20	19,3	10,0	1000	13	76
12	16,0	12,00	32	50	66,0	22,0	17,5	15,4	19,0	M 12	22	23,5	13,5	860	13	115
14	19,0	13,50	36	57	75,0	25,0	20,0	16,8	22,0	M 14	25	21,0	17,0	750	16	170
16	21,0	15,00	42	64	85,0	27,0	22,0	19,3	22,0	M 16	28	32,0	21,5	660	15	230
18	23,0	16,50	46	71	94,0	31,0	25,0	21,8	27,0	M 18x1,5	32	38,5	26,0	600	15	320
20	25,0	18,00	50	77	102,0	34,0	27,5	24,3	32,0	M 20x1,5	33	44,0	31,5	540	14	415
22	28,0	20,00	54	84	111,0	37,0	30,0	25,8	32,0	M 22x1,5	37	53,0	38,0	500	15	540
25	31,0	22,00	60	94	124,0	42,0	33,5	29,6	36,0	M 24x2	42	62,0	47,0	440	15	750
30	37,0	25,00	70	110	145,0	51,0	40,0	34,8	41,0	M 30x2	51	82,0	64,0	370	17	1130
35	43,0	28,00	80	125	165,0	58,0	46,0	37,7	50,0	M 36x2	56	101,0	80,0	330	19	1600
40	49,0	35,00	90	142	187,0	69,0	57,0	44,2	60,0	M 42x2	60	124,0	116,0	290	16	2770
50	60,0	45,00	116	160	218,0	78,0	65,0	55,9	65,0	M 48x2	65	308,0	185,0	230	14	5000

only for short-term revolutions recommended

Materials:

Housing: up to size 12 turned from free-cutting steel to 11SMn30+C galvanised, from size 14 forged from heat-treated steel C22, M1023 galvanised
Size 50 turned from heat-treated steel C45 galvanised

Insert: Special high strength bronze to CuSn8

Ball: Bearing steel to 100Cr6, hardened, ground, polished

This series is also available sealed (see page 52) or with threaded bolt (see page 53).

Cetop connections see page 54.

¹⁾ without lubrication hole

Rod Ends Series K - requiring maintenance

Series GAS

Rod End with male thread regreasable through grease nipple in the housing

Especially suited for high speed applications

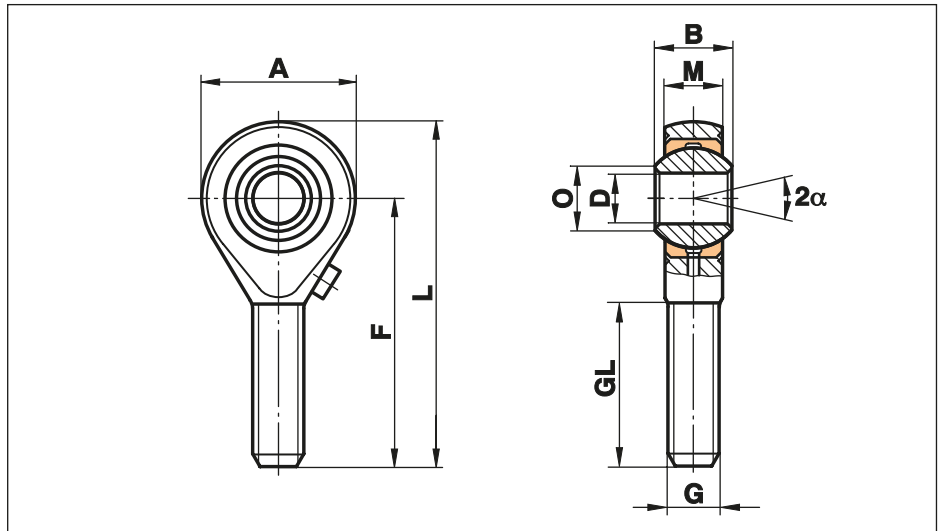

Size (D H7)	B	M	A	F	L	O	G	GL	Static load C ₀ kN	Dynamic load C kN	Limiting speed rev/min	Maximum Pivoting Angle α (°)	Weight g
2 ¹⁾	4,5	3,60	9	20	24,5	2,6	M 2	12	0,6	1,1		16	3
3 ¹⁾	6,0	4,50	14	26	33,0	5,1	M 3	15	1,5	1,8		14	6
5 ¹⁾	8,0	6,00	18	33	42,0	7,7	M 5	19	4,3	3,3		13	13
6	9,0	6,75	20	36	46,0	8,9	M 6	21	6,0	4,3	1500	13	20
8	12,0	9,00	24	42	54,0	10,4	M 8	25	11,0	7,1	1200	14	33
10	14,0	10,50	28	48	62,0	12,9	M 10	28	17,4	10,0	1000	13	56
12	16,0	12,00	32	54	70,0	15,4	M 12	32	23,5	13,5	860	13	87
14	19,0	13,50	36	60	78,0	16,8	M 14	38	21,0	17,0	750	16	129
16	21,0	15,00	42	66	87,0	19,3	M 16	40	32,0	21,5	660	15	189
18	23,0	16,50	46	72	95,0	21,8	M 18x1,5	44	38,5	26,0	600	15	267
20	25,0	18,00	50	78	103,0	24,3	M 20x1,5	47	44,0	31,5	540	14	348
22	28,0	20,00	54	84	111,0	25,8	M 22x1,5	51	53,0	38,0	500	15	443
25	31,0	22,00	60	94	124,0	29,6	M 24x2	58	62,0	47,0	440	15	600
30	37,0	25,00	70	110	145,0	34,8	M 30x2	71	82,0	64,0	370	17	1030
35	43,0	28,00	80	125	165,0	37,7	M 36x2	73	101,0	80,0	330	19	1600
40	49,0	35,00	90	142	187,0	44,2	M 42x2	78	124,0	116,0	290	16	2550
50	60,0	45,00	116	185	243,0	55,9	M 48x2	105	308,0	185,0	230	14	4800

only for short-term revolutions recommended

Materials:

Housing: up to size 12 turned from free-cutting steel to 11SMn30+C galvanised, from size 14 forged from heat-treated steel C22, M1023 galvanised
Size 50 turned from heat-treated steel C45 galvanised

Insert: Special high strength bronze to CuSn8

Ball: Bearing steel to 100Cr6, hardened, ground, polished

This series is also available sealed (see page 52) or with threaded bolt (see page 53).

¹⁾ without lubrication hole

Rod Ends Series K - Extra Heavy Duty

Series GIXS

Rod End with female thread regreasable through grease nipple in the housing

Especially suitable for high pressure and tension loads

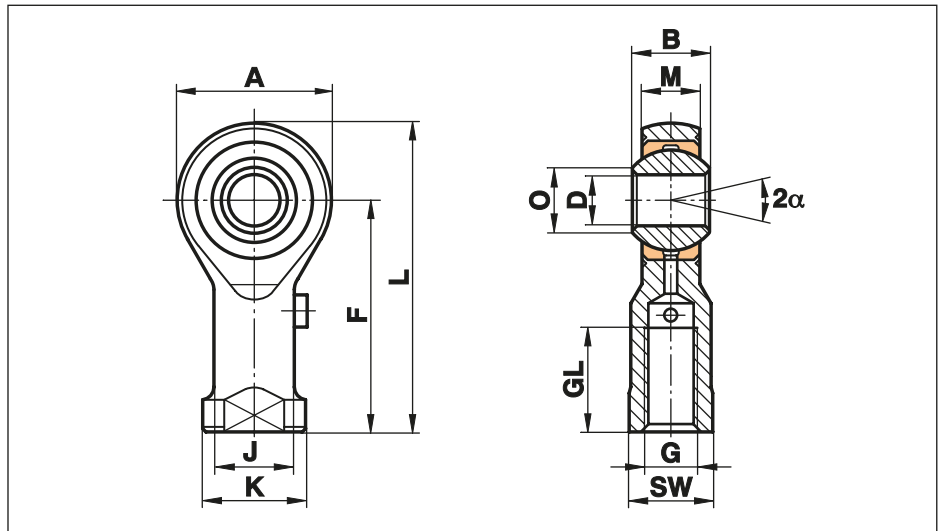

Size (D H7)	B	M	A	F	L	K	J	O	SW	G	GL	Static load C ₀ kN	Dynamic load C kN	Limiting speed rev/min	Maximum Pivoting Angle α (°)	Weight g
6	9	6,75	20	30	40	13	10,0	8,9	11	M 6	12	16,7	4,3	1500	13	27
8	12	9,00	24	36	48	16	12,5	10,4	13	M 8	16	25,5	7,1	1200	14	46
10	14	10,50	28	43	57	19	15,0	12,9	17	M 10	20	34,8	10,0	1000	13	76
12	16	12,00	32	50	66	22	17,5	15,4	19	M 12	22	42,0	13,3	860	13	115
14	19	13,50	36	57	75	25	20,0	16,8	22	M 14	25	57,0	17,0	750	16	170
16	21	15,00	42	64	85	27	22,0	19,3	22	M 16	28	67,5	21,5	660	15	230
18	23	16,50	46	71	94	31	25,0	21,8	27	M 18x1,5	32	81,5	26,0	600	15	320
20	25	18,00	50	77	102	34	27,5	24,3	32	M 20x1,5	33	93,5	31,5	540	14	415
22	28	20,00	54	84	111	37	30,0	25,8	32	M 22x1,5	37	114,0	38,0	500	15	540
25	31	22,00	60	94	124	42	33,5	29,6	36	M 24x2	42	135,0	47,0	440	15	750
30	37	25,00	70	110	145	51	40,0	34,8	41	M 30x2	51	184,0	64,0	370	17	1130

only for short-term revolutions recommended

Materials:

Housing: forged from heat-treated galvanised steel 42CrMo4 Aisi 4140

Insert: Special high strength bronze to CuSn8

Ball: Bearing steel to 100Cr6, Aisi 52100, hardened, ground, polished

This series is also available sealed (see page 52) or with threaded bolt (see page 53).

Cetop connections see page 54.

Rod Ends Series K - Extra Heavy Duty

Series GAXS

Rod End with male thread regreasable through grease nipple in the housing

Especially suitable for high pressure and tension loads

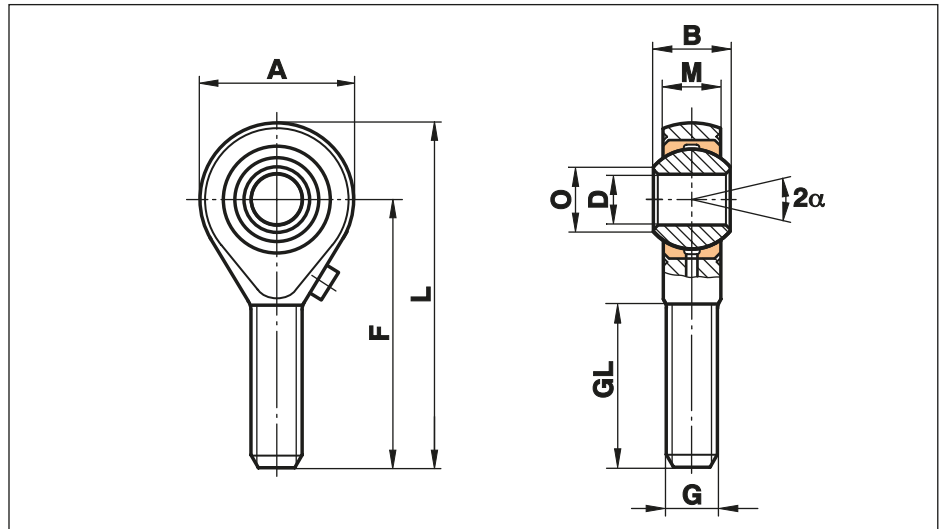

Size (D H7)	B	M	A	F	L	O	G	GL	Static load C ₀ kN	Dynamic load C kN	Limiting speed rev/min	Maximum Pivoting Angle α (°)	Weight g
6	9	6,75	20	36	46	8,9	M 6	21	9,8	4,3	1500	only for short-term revolutions recommended	20
8	12	9,00	24	42	54	10,4	M 8	25	19,5	7,1	1200		33
10	14	10,50	28	48	62	12,9	M 10	28	31,4	10,0	1000		56
12	16	12,00	32	54	70	15,4	M 12	32	42,0	13,5	860		87
14	19	13,50	36	60	78	16,8	M 14	38	57,0	17,0	750		129
16	21	15,00	42	66	87	19,3	M 16	40	67,5	21,5	660		189
18	23	16,50	46	72	95	21,8	M 18x1,5	44	81,5	26,0	600		267
20	25	18,00	50	78	103	24,3	M 20x1,5	47	93,5	31,5	540		348
22	28	20,00	54	84	111	25,8	M 22x1,5	51	114,0	38,0	500		443
25	31	22,00	60	94	124	29,6	M 24x2	57	135,0	47,0	440		600
30	37	25,00	70	110	145	34,8	M 30x2	71	184,0	64,0	370	1030	

Materials:

Housing: forged from heat-treated galvanised steel 42CrMo4 Aisi 4140

Insert: Special high strength bronze to CuSn8

Ball: Bearing steel to 100Cr6, Aisi 52100, hardened, ground, polished

This series is also available sealed (see page 52) or with threaded bolt (see page 53).

Rod Ends Series K - stainless housing - requiring maintenance

Series GIRS

Rod End with female thread regreasable through grease nipple in the housing

For use in corrosive environments

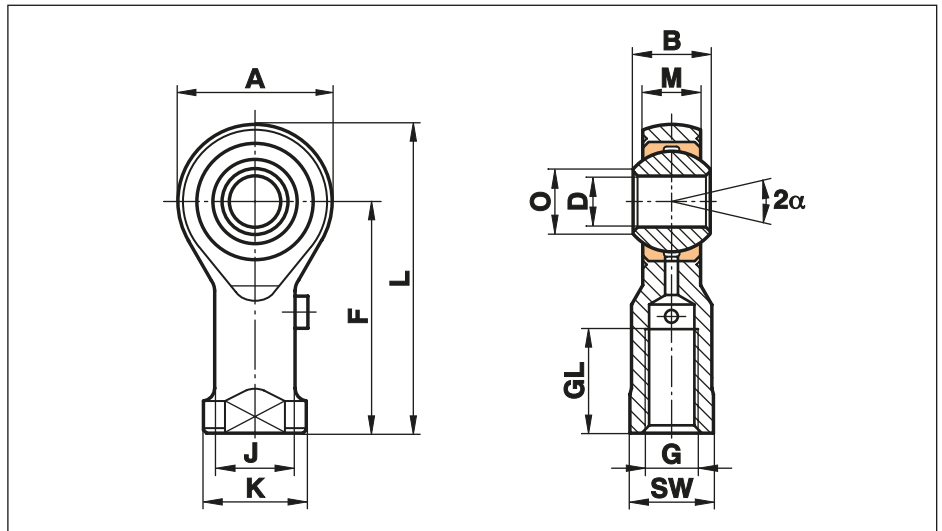

Size (D H7)	B	M	A	F	L	K	J	O	SW	G	GL	Static load C ₀ kN	Dynamic load C kN	Limiting speed rev/min	Maximum Pivoting Angle α (°)	Weight g
3 ¹⁾	6	4,50	14	21	28	6,5	5,0	5,1	5,5	M 3	10	8,0	1,8		14	6
5	8	6,00	18	27	36	11,0	9,0	7,7	9,0	M 5	10	11,8	3,3	1200	13	18
6	9	6,75	20	30	40	13,0	10,0	8,9	11,0	M 6	12	13,1	4,3	1500	13	27
8	12	9,00	24	36	48	16,0	12,5	10,4	13,0	M 8	16	20,7	7,1	1200	14	46
10	14	10,50	28	43	57	19,0	15,0	12,9	17,0	M 10	20	28,3	10,0	1000	13	76
12	16	12,00	32	50	66	22,0	17,5	15,4	19,0	M 12	22	34,5	13,5	860	13	115
14	19	13,50	36	57	75	25,0	20,0	16,8	22,0	M 14	25	39,5	17,0	750	16	170
16	21	15,00	42	64	85	27,0	22,0	19,3	22,0	M 16	28	60,5	21,5	660	15	230
18	23	16,50	46	71	94	31,0	25,0	21,8	27,0	M 18x1,5	32	73,0	26,0	600	15	320
20	25	18,00	50	77	102	34,0	27,5	24,3	32,0	M 20x1,5	33	83,0	31,5	540	14	415
22	28	20,00	54	84	111	37,0	30,0	25,8	32,0	M 22x1,5	37	100,0	38,0	500	15	540
25	31	22,00	60	94	124	42,0	33,5	29,6	36,0	M 24x2	42	118,0	47,1	440	15	750
30	37	25,00	70	110	145	51,0	40,0	34,8	41,0	M 30x2	51	155,0	64,0	370	17	1130
35	43	28,00	80	125	165	58,0	46,0	37,7	50,0	M 36x2	56	191,0	80,0	330	19	1600
40	49	35,00	90	142	187	69,0	57,0	44,2	60,0	M 42x2	60	235,0	116,0	290	16	2770

only for short-term revolutions recommended

Materials:

Housing: Stainless steel to 1.4057, Aisi 431, forged, polished size 40 turned from stainless steel to 1.4057, Aisi 431

Insert: Special high strength bronze to CuSn8

Ball: Bearing steel to 100Cr6, Aisi 52100, hardened, ground, polished, hard chrome plated on the running surface

On request: other slide pairings possible

This series is also available sealed (see page 52) or with threaded bolt (see page 53).

Cetop connections see page 54.

¹⁾ without lubrication hole

Rod Ends Series K - stainless housing - requiring maintenance

Series GARS

Rod End with male thread regreasable through grease nipple in the housing

For use in corrosive environments

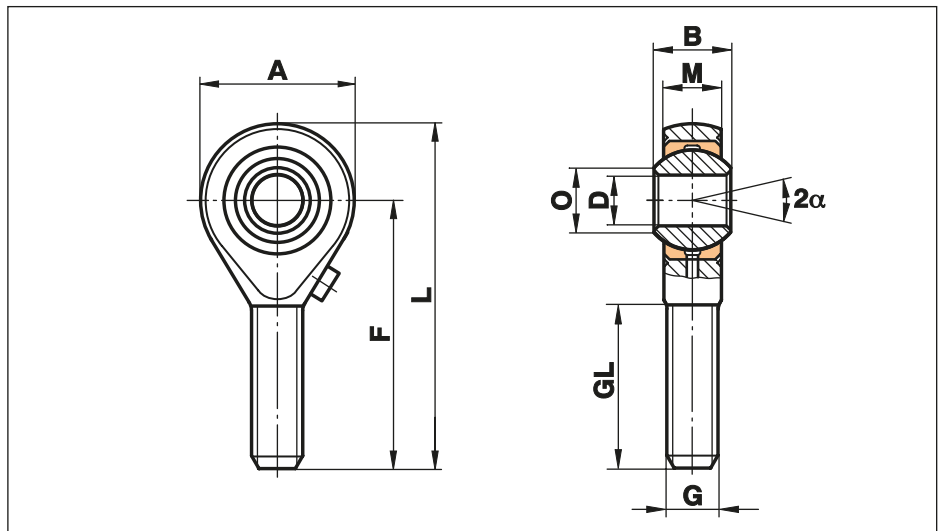

Size (D H7)	B	M	A	F	L	O	G	GL	Static load C ₀ kN	Dynamic load C kN	Limiting speed rev/min	Maximum Pivoting Angle α (°)	Weight g	
3 ¹⁾	6	4,50	14	26	33	5,1	M 3	15	7,0	1,8	only for short-term revolutions recommended	14	6	
5 ¹⁾	8	6,00	18	33	42	7,7	M 5	19	6,2	3,3		13	13	
6	9	6,75	20	36	46	8,9	M 6	21	8,8	4,3		1500	13	20
8	12	9,00	24	42	54	10,4	M 8	25	16,1	7,1		1200	14	33
10	14	10,50	28	48	62	12,9	M 10	28	25,5	10,0		1000	13	56
12	16	12,00	32	54	70	15,4	M 12	32	34,5	13,5		860	13	87
14	19	13,50	36	60	78	16,8	M 14	38	39,5	17,0		750	16	129
16	21	15,00	42	66	87	19,3	M 16	40	60,5	21,5		660	15	189
18	23	16,50	46	72	95	21,8	M 18x1,5	44	73,0	26,0		600	15	267
20	25	18,00	50	78	103	24,3	M 20x1,5	47	83,0	31,5		540	14	348
22	28	20,00	54	84	111	25,8	M 22x1,5	51	100,0	38,0		500	15	443
25	31	22,00	60	94	124	29,6	M 24x2	57	118,0	47,0		440	15	600
30	37	25,00	70	110	145	34,8	M 30x2	71	155,0	64,0		370	17	1030
35	43	28,00	80	125	165	37,7	M 36x2	73	191,0	80,0		330	19	1600
40	49	35,00	90	142	187	44,2	M 42x2	78	235,0	116,0	290	16	2570	

Materials:

Housing: Stainless steel to 1.4057, Aisi 431, forged, polished size 40 turned from stainless steel to 1.4057, Aisi 431

Insert: Special high strength bronze to CuSn8

Ball: Bearing steel to 100Cr6, Aisi 52100, hardened, ground, polished, hard chrome plated on the running surface

On request: other slide pairings possible

This series is also available sealed (see page 52) or with threaded bolt (see page 53).

¹⁾ without lubrication hole

Rod Ends Series K - stainless steel - requiring maintenance

Series GIRS..R

Rod End series K with female thread regreasable through grease nipple in the housing

For use in corrosive environments

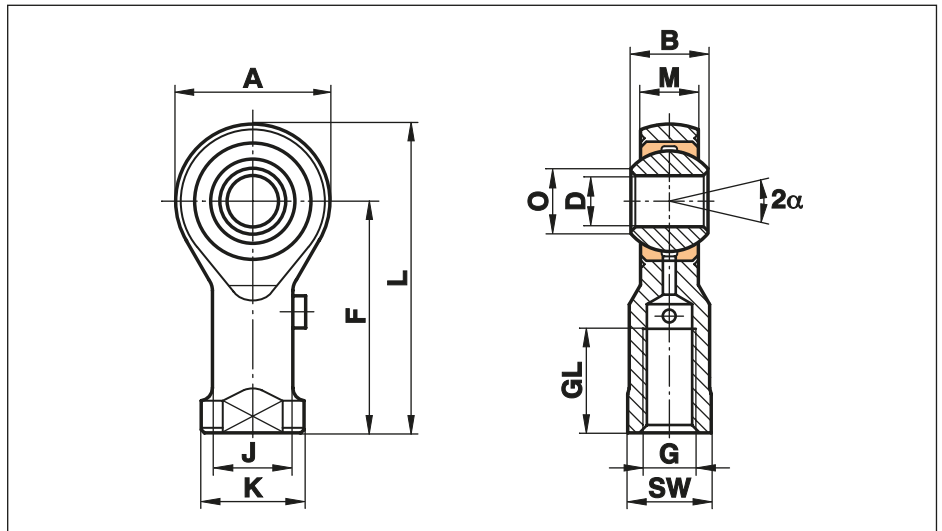

Size (D H7)	B	M	A	F	L	K	J	O	SW	G	GL	Static load C ₀ kN	Dynamic load C kN	Limiting speed rev/min	Maximum Pivoting Angle α (°)	Weight g
3 ¹⁾	6,0	4,50	14	21	28	6,5	5,0	5,1	5,5	M3	10	8,0	1,8		14	6
5	8,0	6,00	18	27	36	11,0	9,0	7,7	9,0	M5	10	11,8	3,3	1200	13	18
6	9,0	6,75	20	30	40	13,0	10,0	8,9	11,0	M6	12	13,1	4,3	1500	13	27
8	12,0	9,00	24	36	48	16,0	12,5	10,4	13,0	M8	16	20,7	7,1	1200	14	46
10	14,0	10,50	28	43	57	19,0	15,0	12,9	17,0	M10	20	28,3	10,0	1000	13	76
12	16,0	12,00	32	50	66	22,0	17,5	15,4	19,0	M12	22	34,5	13,5	860	13	115
14	19,0	13,50	36	57	75	25,0	20,0	16,8	22,0	M14	25	39,5	17,0	750	16	170
16	21,0	15,00	42	64	85	27,0	22,0	19,3	22,0	M16	28	60,5	21,5	660	15	230
18	23,0	16,50	46	71	94	31,0	25,0	21,8	27,0	M18x1,5	32	73,0	26,0	600	15	320
20	25,0	18,00	50	77	102	34,0	27,5	24,3	32,0	M20x1,5	33	83,0	31,5	540	14	415
22	28,0	20,00	54	84	111	37,0	30,0	25,8	32,0	M22x1,5	37	100,0	38,0	500	15	540
25	31,0	22,00	60	94	124	42,0	33,5	29,6	36,0	M24x2	42	118,0	47,1	440	15	750
30	37,0	25,00	70	110	145	50,0	40,0	34,8	41,0	M30x2	51	155,0	64,0	370	17	1130
35	43,0	28,00	80	125	165	58,0	46,0	37,7	50,0	M36x2	56	191,0	80,0	330	19	1600
40	49,0	35,00	90	142	187	69,0	57,0	44,2	60,0	M42x2	60	235,0	116,0	290	16	2770

only for short-term revolutions recommended

Materials:

Housing: Stainless steel to 1.4057, Aisi 431, forged, polished size 40 turned from stainless steel to 1.4057, Aisi 431

Insert: Special high strength bronze to CuSn8

Ball: Stainless steel to 1.4034, hardened, ground, polished

On request: other slide pairings possible

This series is also available sealed (see page 52) or with threaded bolt (see page 53).

Cetop connections see page 54.

¹⁾ without lubrication hole

Rod Ends Series K - stainless steel - requiring maintenance

Series GARS..R

Rod End series K with male thread regreasable through grease nipple in the housing

For use in corrosive environments

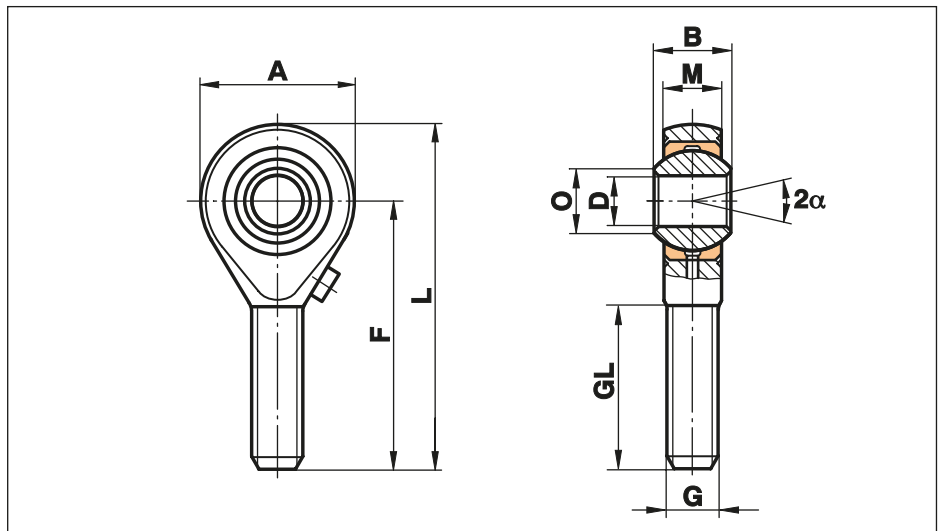

Size (D H7)	B	M	A	F	L	O	G	GL	Static load C ₀ kN	Dynamic load C kN	Limiting speed rev/min	Maximum Pivoting Angle α (°)	Weight g
3 ¹⁾	6	4,50	14	26	33	5,1	M3	15	7,0	1,8		14	6
5 ¹⁾	8	6,00	18	33	42	7,7	M5	19	6,2	3,3		13	13
6	9	6,75	20	36	46	8,9	M6	21	8,8	4,3	1500	13	20
8	12	9,00	24	42	54	10,4	M8	25	16,1	7,1	1200	14	33
10	14	10,50	28	48	62	12,9	M10	28	25,5	10,0	1000	13	56
12	16	12,00	32	54	70	15,4	M12	32	34,5	13,5	860	13	87
14	19	13,5	36	60	78	16,8	M14	38	39,5	17,0	750	16	129
16	21	15,00	42	66	87	19,3	M16	40	60,5	21,5	660	15	189
18	23	16,50	46	72	95	21,8	M18x1,5	44	73,0	26,0	600	15	267
20	25	18,00	50	78	103	24,3	M20x1,5	47	83,0	31,5	540	14	348
22	28	20,00	54	84	111	25,8	M22x1,5	51	100,0	38,0	500	15	443
25	31	22,00	60	94	124	29,6	M24x2	57	118,0	47,0	440	15	600
30	37	25,00	70	110	145	34,8	M30x2	71	155,0	64,0	370	17	1030
35	43	28,00	80	125	165	37,7	M36x2	73	191,0	80,0	330	19	1600
40	49	35,00	90	142	187	44,2	M42x2	78	235,0	116,0	290	16	2570

only for short-term revolutions recommended

Materials:

Housing: Stainless steel to 1.4057, Aisi 431, forged, polished
size 40 turned from stainless steel to 1.4057, Aisi 431

Insert: Special high strength bronze to CuSn8

Ball: Stainless steel to 1.4034, hardened, ground, polished

On request: other slide pairings possible

This series is also available sealed (see page 52) or with threaded bolt (see page 53).

¹⁾ without lubrication hole

Rod Ends Series K - Maintenance Free

Series GISW

Rod End with female thread and PTFE liner

For use at dynamic loads

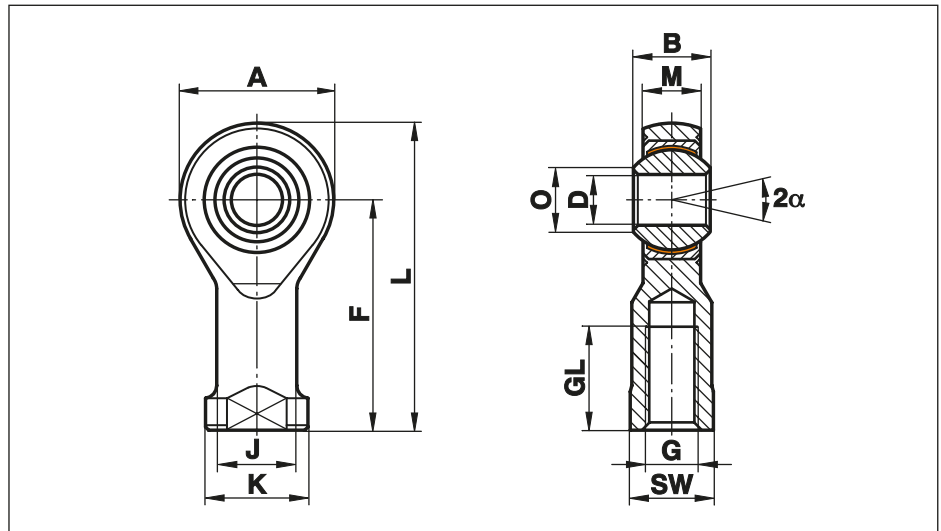

Size (D H7)	B	M	A	F	L	K	J	O	SW	G	GL	Static load C ₀ kN	Dynamic load C kN	Limiting speed rev/min	Maximum Pivoting Angle α (°)	Weight g	
5	8	6,00	18	27	36	11	9,0	7,7	9	M 5	10	8,0	7,5	600	only for short-term revolutions recommended	13	18
6	9	6,75	20	30	40	13	10,0	8,9	11	M 6	12	8,9	9,3	530		13	27
8	12	9,00	24	36	48	16	12,5	10,4	13	M 8	16	14,1	16,7	420		14	46
10	14	10,50	28	43	57	19	15,0	12,9	17	M 10	20	19,3	23,4	350		13	76
12	16	12,00	32	50	66	22	17,5	15,4	19	M 12	22	23,5	32,0	300		13	115
14	19	13,50	36	57	75	25	20,0	16,8	22	M 14	25	21,0	42,0	260		16	170
16	21	15,00	42	64	85	27	22,0	19,3	22	M 16	28	32,0	52,5	230		15	230
18	23	16,50	46	71	94	31	25,0	21,8	27	M 18x1,5	32	38,5	64,0	210		15	320
20	25	18,00	50	77	102	34	27,5	24,3	32	M 20x1,5	33	44,0	78,0	190		14	415
22	28	20,00	54	84	111	37	30,0	25,8	32	M 22x1,5	37	53,0	97,0	170		15	540
25	31	22,00	60	94	124	42	33,5	29,6	36	M 24x2	42	62,0	122,0	150	15	750	
30	37	25,00	70	110	145	51	40,0	34,8	41	M 30x2	51	82,0	168,0	130	17	1130	
35	43	28,00	80	125	165	58	46,0	37,7	50	M 36x2	56	101,0	206,0	110	19	1600	
40	49	35,00	90	142	187	69	57,0	44,2	60	M 42x2	60	124,0	286,0	100	16	2770	
50	60	45,00	116	160	218	78	65,0	55,9	65	M 48x2	65	308,0	485,0	80	14	5000	

Materials:

Housing: up to size 12 turned, from free-cutting steel to 11SMn30+C, 12L13, galvanised
from size 14 forged, from heat-treated galvanised steel to C22, M1023
size 50 turned from heat-treated galvanised steel to C45, Aisi 1045

Insert: Free-cutting steel to 11SMn30+C, 12L13, with PTFE liner bonded to the inner surface

Ball: Bearing steel to 100Cr6, Aisi 52100, hardened, ground, polished

This series is also available sealed (see page 52) or with threaded bolt (see page 53).

Cetop connections see page 54.

⚠ Please note: The dynamic load "C" of the bearing of some rod ends is in some sizes higher than the static load "C₀" of the rod end.

Rod Ends Series K - Maintenance Free

Series GASW

Rod End with male thread and PTFE liner

For use at dynamic loads

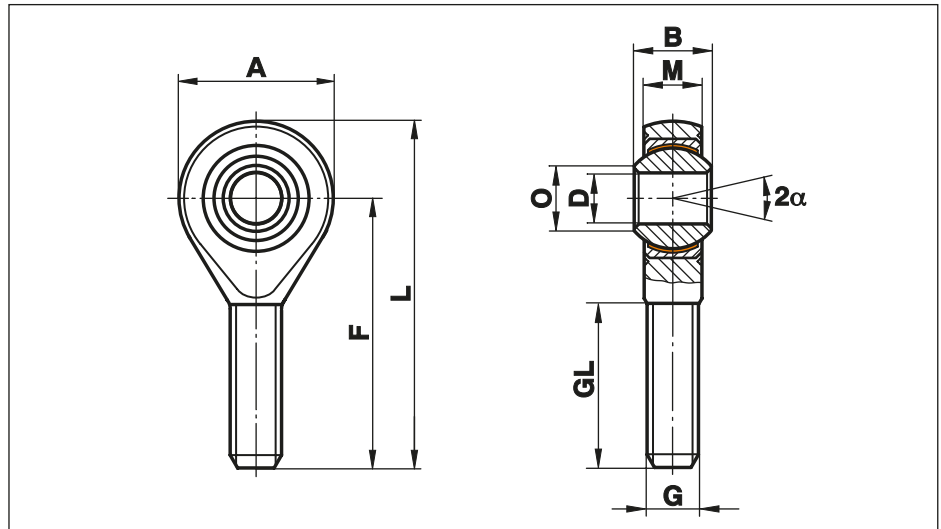

Size (D H7)	B	M	A	F	L	O	G	GL	Static load C ₀ kN	Dynamic load C kN	Limiting speed rev/min	Maximum Pivoting Angle α (°)	Weight g
5	8	6,00	18	33	42	7,7	M 5	19	4,3	7,5	600	13	13
6	9	6,75	20	36	46	8,9	M 6	21	6,0	9,3	530	13	20
8	12	9,00	24	42	54	10,4	M 8	25	11,0	16,7	420	14	33
10	14	10,50	28	48	62	12,9	M 10	28	17,4	23,4	350	13	56
12	16	12,00	32	54	70	15,4	M 12	32	23,5	32,0	300	13	87
14	19	13,50	36	60	78	16,8	M 14	38	21,0	42,0	260	16	129
16	21	15,00	42	66	87	19,3	M 16	40	32,0	52,5	230	15	189
18	23	16,50	46	72	95	21,8	M 18x1,5	44	38,5	64,0	210	15	267
20	25	18,00	50	78	103	24,3	M 20x1,5	47	44,0	78,0	190	14	348
22	28	20,00	54	84	111	25,8	M 22x1,5	51	53,0	97,0	170	15	443
25	31	22,00	60	94	124	29,6	M 24x2	57	61,0	122,0	150	15	600
30	37	25,00	70	110	145	34,8	M 30x2	71	82,0	168,0	130	17	1030
35	43	28,00	80	125	165	37,7	M 36x2	73	101,0	206,0	110	19	1600
40	49	35,00	90	142	187	44,2	M 42x2	78	124,0	286,0	100	16	2570
50	60	45,00	116	185	243	55,9	M 48x2	105	308,0	485,0	80	14	4800

Materials:

Housing: up to size 12 turned, from free-cutting steel to 11SMn30+C, 12L13, galvanised
from size 14 forged, from heat-treated galvanised steel to C22, M1023
size 50 turned from heat-treated galvanised steel to C45, Aisi 1045

Insert: Free-cutting steel to 11SMn30+C, 12L13, with PTFE liner bonded to the inner surface

Ball: Bearing steel to 100Cr6, Aisi 52100, hardened, ground, polished

This series is also available sealed (see page 52) or with threaded bolt (see page 53).

⚠ Please note: The dynamic load "C" of the bearing of some rod ends is in some sizes higher than the static load "C₀" of the rod end.

Rod Ends Series K - Heavy duty - Maintenance Free

Series GIXSW

Rod End with female thread and PTFE liner

For use at high pressure and tension loads

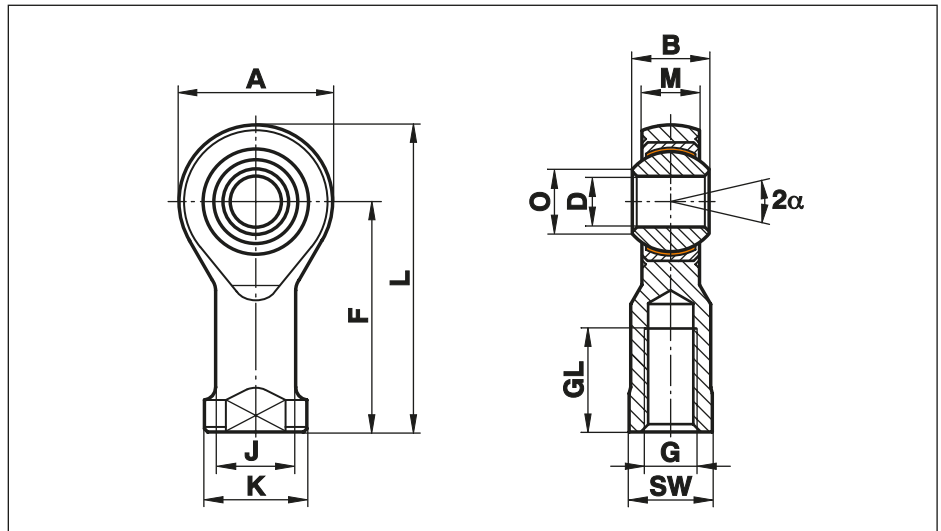

Size (D H7)	B	M	A	F	L	K	J	O	SW	G	GL	Static load C ₀ kN	Dynamic load C kN	Limiting speed rev/min	Maximum Pivoting Angle α (°)	Weight g	
6	9	6,75	20	30	40	13	10,0	8,9	11	M 6	12	16,7	9,3	530	only for short-term revolutions recommended	13	27
8	12	9,00	24	36	48	16	12,5	10,4	13	M 8	16	25,5	16,7	420		14	46
10	14	10,50	28	43	57	19	15,0	12,9	17	M 10	20	34,8	23,4	350		13	76
12	16	12,00	32	50	66	22	17,5	15,4	19	M 12	22	42,0	32,0	300		13	115
14	19	13,50	36	57	75	25	20,0	16,8	22	M 14	25	57,0	42,0	260		16	170
16	21	15,00	42	64	85	27	22,0	19,3	22	M 16	28	67,5	52,5	230		15	230
18	23	16,50	46	71	94	31	25,0	21,8	27	M 18x1,5	32	81,5	64,0	210		15	320
20	25	18,00	50	77	102	34	27,5	24,3	32	M 20x1,5	33	93,5	78,0	190		14	415
22	28	20,00	54	84	111	37	30,0	25,8	32	M 22x1,5	37	114,0	97,0	170		15	540
25	31	22,00	60	94	124	42	33,5	29,6	36	M 24x2	42	135,0	122,0	150		15	750
30	37	25,00	70	110	145	51	40,0	34,8	41	M 30x2	51	184,0	168,0	130	17	1130	
35	43	28,00	80	125	165	58	46,0	37,7	50	M 36x2	56	230,0	205,0	110	19	1600	
40	49	35,00	90	142	187	69	57,0	44,2	60	M 42x2	60	270,0	286,0	100	16	2770	

Materials:

Housing: Heat-treated steel to 42CrMo4, Aisi 4140, forged, galvanised

Insert: Free-cutting steel to 11SMn30+C, 12L13, galvanised, with PTFE liner bonded to the inner surface

Ball: Bearing steel to 100Cr6, Aisi 52100, hardened, ground, polished

This series is also available sealed (see page 52) or with threaded bolt (see page 53).

Cetop connections see page 54.

Rod Ends Series K - Heavy duty - Maintenance Free

Series GAXSW

Rod End with male thread and PTFE liner

For use at high pressure and tension loads

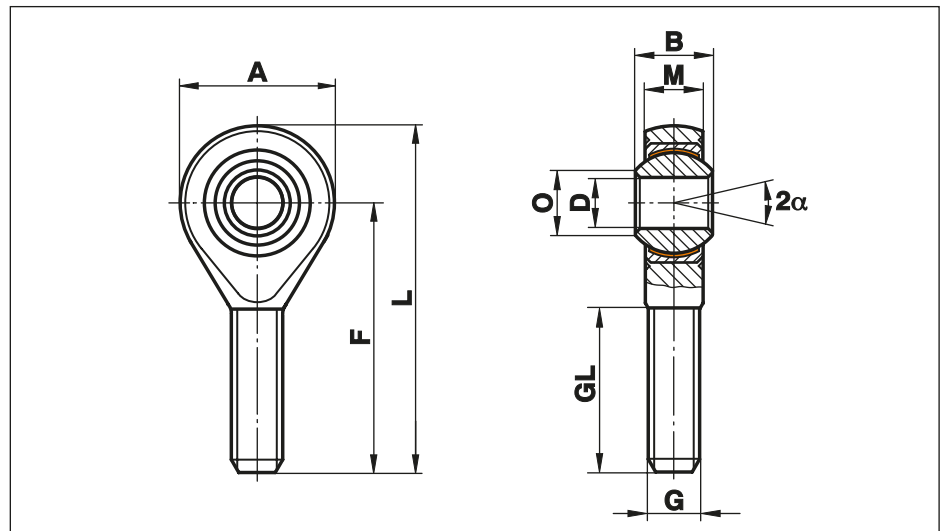

Size (D H7)	B	M	A	F	L	O	G	GL	Static load C ₀ kN	Dynamic load C kN	Limiting speed rev/min	Maximum Pivoting Angle α (°)	Weight g
6	9	6,75	20	36	46	8,9	M 6	21	9,8	9,3	530	13	20
8	12	9,00	24	42	54	10,4	M 8	25	19,5	16,7	420	14	33
10	14	10,50	28	48	62	12,9	M 10	28	31,4	23,4	350	13	56
12	16	12,00	32	54	70	15,4	M 12	32	42,0	32,0	300	13	87
14	19	13,50	36	60	78	16,8	M 14	38	57,0	42,0	260	16	129
16	21	15,00	42	66	87	19,3	M 16	40	67,0	52,5	230	15	189
18	23	16,50	46	72	95	21,8	M 18x1,5	44	81,5	64,0	210	15	267
20	25	18,00	50	78	103	24,3	M 20x1,5	47	93,5	78,0	190	14	348
22	28	20,00	54	84	111	25,8	M 22x1,5	51	114,0	97,0	170	15	443
25	31	22,00	60	94	124	29,6	M 24x2	57	135,0	122,0	150	15	600
30	37	25,00	70	110	145	34,8	M 30x2	71	184,0	168,0	130	17	1030
35	43	28,00	80	125	165	37,7	M 36x2	73	230,0	205,0	110	19	1600

Materials:

Housing: Heat-treated steel to 42CrMo4, Aisi 4140, forged, galvanised

Insert: Free-cutting steel to 11SMn30+C, 12L13, galvanised, with PTFE liner bonded to the inner surface

Ball: Bearing steel to 100Cr6, Aisi 52100, hardened, ground, polished

This series is also available sealed (see page 52) or with threaded bolt (see page 53).

Rod Ends Series K - Stainless, Maintenance Free

Series GIRSW

Rod End with female thread and PTFE liner

For use at high dynamic pressure and tension loads in corrosive environments

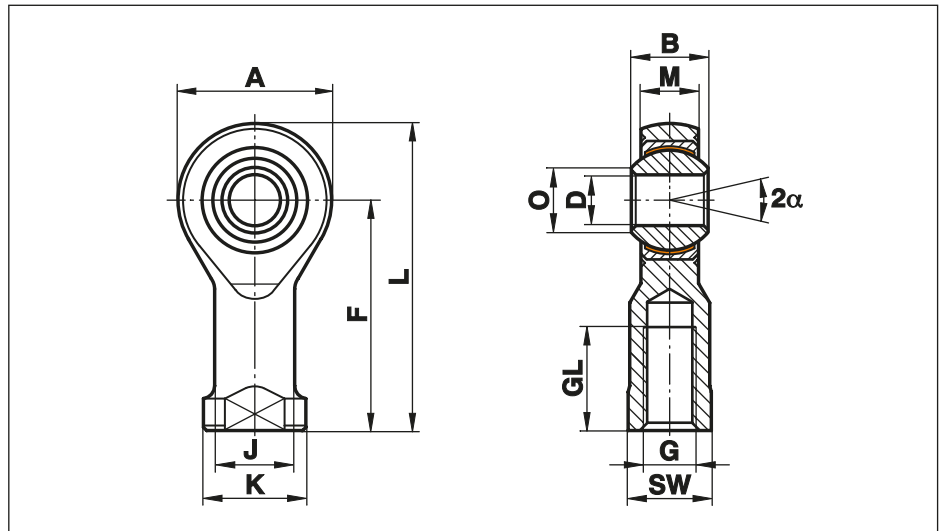

Size (D H7)	B	M	A	F	L	K	J	O	SW	G	GL	Static load C ₀ kN	Dynamic load C kN	Limiting speed rev/min	Maximum Pivoting Angle α (°)	Weight g	
4 ¹⁾	7	5,25	14	24	31	9,5	7,8	6,5	8	M 4	12	2,5	5,1	only for short-term revolutions recommended	14	11	
5	8	6,00	18	27	36	11,0	9,0	7,7	9	M 5	10	11,8	7,5		600	13	18
6	9	6,75	20	30	40	13,0	10,0	8,9	11	M 6	12	13,1	9,3		530	13	27
8	12	9,00	24	36	48	16,0	12,5	10,4	13	M 8	16	20,7	16,7		420	14	46
10	14	10,50	28	43	57	19,0	15,0	12,9	17	M 10	20	28,3	23,4		350	13	76
12	16	12,00	32	50	66	22,0	17,5	15,4	19	M 12	22	34,5	32,0		300	13	115
14	19	13,50	36	57	75	25,0	20,0	16,8	22	M 14	25	39,5	42,0		260	16	170
16	21	15,00	42	64	85	27,0	22,0	19,3	22	M 16	28	60,5	52,5		230	15	230
18	23	16,50	46	71	94	31,0	25,0	21,8	27	M 18x1,5	32	73,0	64,0		210	15	320
20	25	18,00	50	77	102	34,0	27,5	24,3	32	M 20x1,5	33	83,0	78,0		190	14	415
22	28	20,00	54	84	111	37,0	30,0	25,8	32	M 22x1,5	37	100,0	97,0		170	15	540
25	31	22,00	60	94	124	42,0	33,5	29,6	36	M 24x2	42	118,0	122,0		150	15	750
30	37	25,00	70	110	145	50,0	40,0	34,8	41	M 30x2	51	155,0	168,0		130	17	1130
35	43	28,00	80	125	165	58,0	46,0	37,7	50	M 36x2	56	191,0	206,0		110	19	1600
40	49	35,00	90	142	187	69,0	57,0	44,2	60	M 42x2	60	235,0	286,0		100	16	2770

Materials:

Housing: Stainless steel to 1.4057, Aisi 431, forged, polished
size 40 turned from stainless steel to 1.4057, Aisi 431

Insert: Special high strength bronze to CuSn8 with PTFE liner bonded to the inner surface

Ball: Bearing steel to 100Cr6, Aisi 52100, hardened, ground, polished, hard chrome plated on the running surface

This series is also available sealed (see page 52) or with threaded bolt (see page 53).

Cetop connections see page 54.

¹⁾ Size 4 on request. Housing turned from stainless steel to 1.4305, Aisi 303 / 1.4301, Aisi 304

! Please note: The dynamic load "C" of the bearing of some rod ends is in some sizes higher than the static load "C₀" of the rod end.

Rod Ends Series K - Stainless, Maintenance Free

Series GARSW

Rod End with male thread and PTFE liner

For use at high dynamic pressure and tension loads in corrosive environments

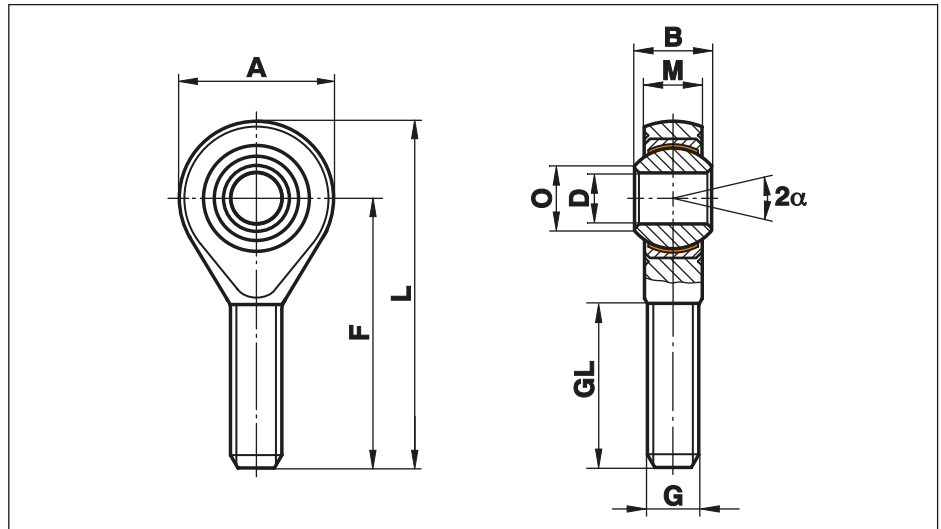

Size (D H7)	B	M	A	F	L	O	G	GL	Static load C ₀ kN	Dynamic load C kN	Limiting speed rev/min	Maximum Pivoting Angle α (°)	Weight g	
4 ¹⁾	7	5,25	14	30	37	6,5	M 4	19	2,5	5,1	only for short-term revolutions recommended	14	9	
5	8	6,00	18	33	42	7,7	M 5	19	6,2	7,5		600	13	13
6	9	6,75	20	36	46	8,9	M 6	21	8,8	9,3		530	13	20
8	12	9,00	24	42	54	10,4	M 8	25	16,1	16,7		420	14	33
10	14	10,50	28	48	62	12,9	M 10	28	25,5	23,4		350	13	56
12	16	12,00	32	54	70	15,4	M 12	32	34,5	32,0		300	13	87
14	19	13,50	36	60	78	16,8	M 14	38	39,5	42,0		260	16	129
16	21	15,00	42	66	87	19,3	M 16	40	60,5	52,5		230	15	189
18	23	16,50	46	72	95	21,8	M 18x1,5	44	73,0	64,0		210	15	267
20	25	18,00	50	78	103	24,3	M 20x1,5	47	83,0	78,0		190	14	348
22	28	20,00	54	84	111	25,8	M 22x1,5	51	100,0	97,0		170	15	443
25	31	22,00	60	94	124	29,6	M 24x2	57	118,0	122,0		150	15	600
30	37	25,00	70	110	145	34,8	M 30x2	71	155,0	168,0		130	17	1030
35	43	28,00	80	125	165	37,7	M 36x2	73	191,0	206,0	110	19	1600	
40	49	35,00	90	142	187	44,2	M 42x2	78	235,0	286,0	100	16	2570	

Materials:

Housing: Stainless steel to 1.4057, Aisi 431, forged, polished
size 40 turned from stainless steel to 1.4057, Aisi 431

Insert: Special high strength bronze to CuSn8 with PTFE liner bonded to the inner surface

Ball: Bearing steel to 100Cr6, Aisi 52100, hardened, ground, polished, hard chrome plated on the running surface

This series is also available sealed (see page 52) or with threaded bolt (see page 53).

¹⁾ Size 4 on request. Housing turned from stainless steel to 1.4305, Aisi 303 / 1.4301, Aisi 304

⚠ Please note: The dynamic load "C" of the bearing of some rod ends is in some sizes higher than the static load "C₀" of the rod end.

Rod Ends Series K - Stainless, Maintenance Free

Series

GIRSW..R

Rod End with female thread and PTFE liner

For use at high dynamic pressure and tension loads in corrosive environments

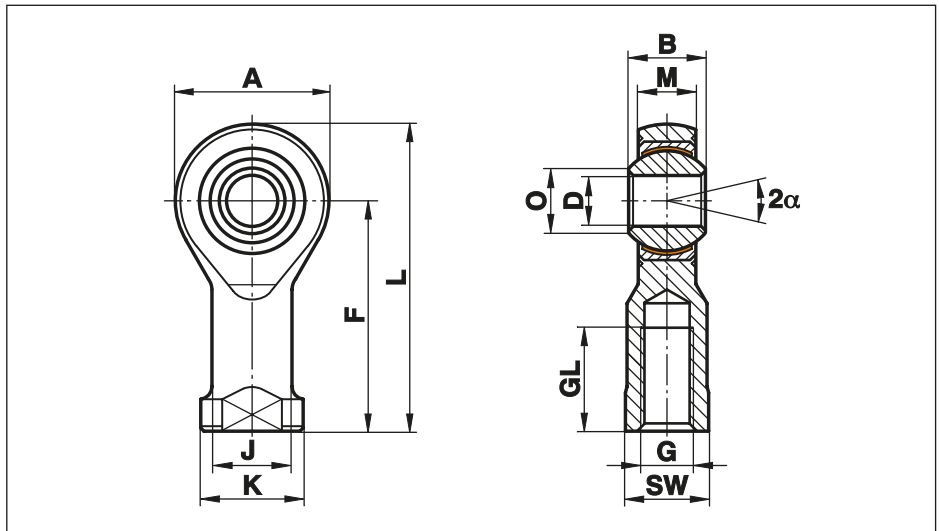

Size (D H7)	B	M	A	F	L	K	J	O	SW	G	GL	Static load C ₀ kN	Dynamic load C kN	Limiting speed rev/min	Maximum Pivoting Angle α (°)	Weight g	
4 ¹⁾	7	5,25	14	24	31	9,5	7,8	6,5	8	M 4	12	2,5	5,1	only for short-term revolutions recommended	14	11	
5	8	6,00	18	27	36	11,0	9,0	7,7	9	M 5	10	11,8	7,5		600	13	18
6	9	6,75	20	30	40	13,0	10,0	8,9	11	M 6	12	13,1	9,3		530	13	27
8	12	9,00	24	36	48	16,0	12,5	10,4	13	M 8	16	20,7	16,7		420	14	46
10	14	10,50	28	43	57	19,0	15,0	12,9	17	M 10	20	28,3	23,4		350	13	76
12	16	12,00	32	50	66	22,0	17,5	15,4	19	M 12	22	34,5	32,0		300	13	115
14	19	13,50	36	57	75	25,0	20,0	16,8	22	M 14	25	39,5	42,0		260	16	170
16	21	15,00	42	64	85	27,0	22,0	19,3	22	M 16	28	60,5	52,5		230	15	230
18	23	16,50	46	71	94	31,0	25,0	21,8	27	M 18x1,5	32	73,0	64,0		210	15	320
20	25	18,00	50	77	102	34,0	27,5	24,3	32	M 20x1,5	33	83,0	78,0		190	14	415
22	28	20,00	54	84	111	37,0	30,0	25,8	32	M 22x1,5	37	100,0	97,0		170	15	540
25	31	22,00	60	94	124	42,0	33,5	29,6	36	M 24x2	42	118,0	122,0		150	15	750
30	37	25,00	70	110	145	50,0	40,0	34,8	41	M 30x2	51	155,0	168,0		130	17	1130
35	43	28,00	80	125	165	58,0	46,0	37,7	50	M 36x2	56	191,0	206,0		110	19	1600
40	49	35,00	90	142	187	69,0	57,0	44,2	60	M 42x2	60	235,0	286,0		100	16	2770

Materials:

Housing: Stainless steel to 1.4057, Aisi 431, forged, polished
size 40 turned from stainless steel to 1.4057, Aisi 431

Insert: Special high strength bronze to CuSn8 with PTFE liner bonded to the inner surface

Ball: Stainless steel 1.4034, hardened, ground, polished

This series is also available sealed (see page 52) or with threaded bolt (see page 53).

Cetop connections see page 54.

¹⁾ Size 4 on request. Housing turned from stainless steel to 1.4305, Aisi 303 / 1.4301, Aisi 304

⚠ Please note: The dynamic load "C" of the bearing of some rod ends is in some sizes higher than the static load "C₀" of the rod end.

Rod Ends Series K - Stainless, Maintenance Free

Series

GARSW..R

Rod End with male thread and PTFE liner

For use at high dynamic pressure and tension loads in corrosive environments

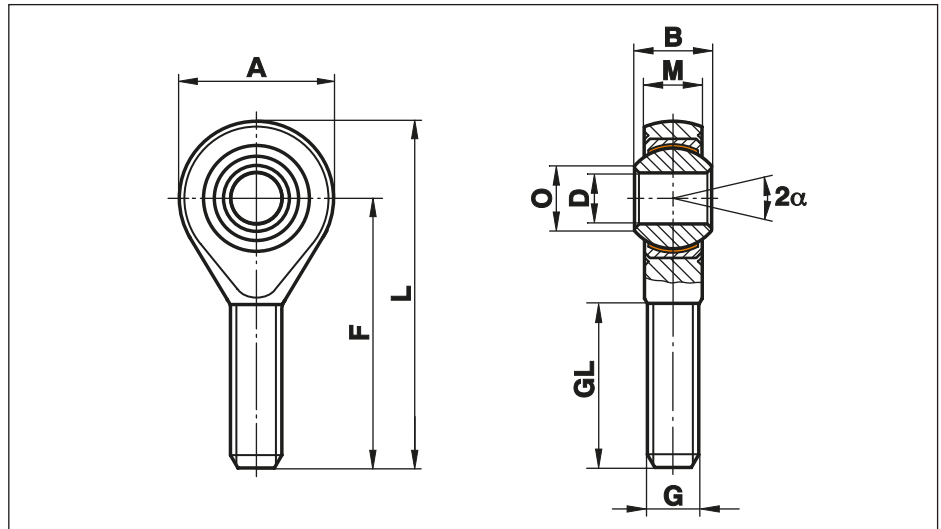

Size (D H7)	B	M	A	F	L	O	G	GL	Static load C ₀ kN	Dynamic load C kN	Limiting speed rev/min	Maximum Pivoting Angle α (°)	Weight g
4 ¹⁾	7	5,25	14	30	37	6,5	M 4	19	2,5	5,1		14	9
5	8	6,00	18	33	42	7,7	M 5	19	6,2	7,5	600	13	13
6	9	6,75	20	36	46	8,9	M 6	21	8,8	9,3	530	13	20
8	12	9,00	24	42	54	10,4	M 8	25	16,1	16,7	420	14	33
10	14	10,50	28	48	62	12,9	M 10	28	25,5	23,4	350	13	56
12	16	12,00	32	54	70	15,4	M 12	32	34,5	32,0	300	13	87
14	19	13,50	36	60	78	16,8	M 14	38	39,5	42,0	260	16	129
16	21	15,00	42	66	87	19,3	M 16	40	60,5	52,5	230	15	189
18	23	16,50	46	72	95	21,8	M 18x1,5	44	73,0	64,0	210	15	267
20	25	18,00	50	78	103	24,3	M 20x1,5	47	83,0	78,0	190	14	348
22	28	20,00	54	84	111	25,8	M 22x1,5	51	100,0	97,0	170	15	443
25	31	22,00	60	94	124	29,6	M 24x2	57	118,0	122,0	150	15	600
30	37	25,00	70	110	145	34,8	M 30x2	71	155,0	168,0	130	17	1030
35	43	28,00	80	125	165	37,7	M 36x2	73	191,0	206,0	110	19	1600
40	49	35,00	90	142	187	44,2	M 42x2	78	235,0	286,0	100	16	2570

only for short-term revolutions recommended

Materials:

Housing: Stainless steel to 1.4057, Aisi 431, forged, polished
size 40 turned from stainless steel to 1.4057, Aisi 431

Insert: Special high strength bronze to CuSn8 with PTFE liner bonded to the inner surface

Ball: Stainless steel 1.4034, hardened, ground, polished

This series is also available sealed (see page 52) or with threaded bolt (see page 53).

¹⁾ Size 4 on request. Housing turned from stainless steel to 1.4305, Aisi 303 / 1.4301, Aisi 304

⚠ Please note: The dynamic load "C" of the bearing of some rod ends is in some sizes higher than the static load "C₀" of the rod end.

Rod Ends Series K - Stainless, Maintenance Free

Series

GIRSW..RR

Rod End with female thread and PTFE liner

For use at high dynamic pressure and tension loads in corrosive environments

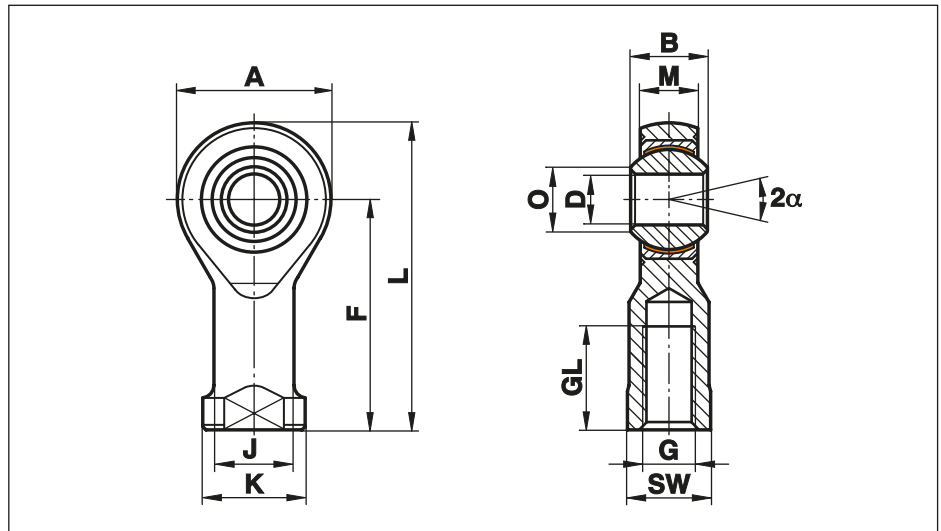

Size (D H7)	B	M	A	F	L	K	J	O	SW	G	GL	Static load C ₀ kN	Dynamic load C kN	Limiting speed rev/min	Maximum Pivoting Angle α (°)	Weight g	
4 ¹⁾	7	5,25	14	24	31	9,5	7,8	6,5	8	M 4	12	2,5	5,1	only for short-term revolutions recommended	14	11	
5	8	6,00	18	27	36	11,0	9,0	7,7	9	M 5	10	11,8	7,5		600	13	18
6	9	6,75	20	30	40	13,0	10,0	8,9	11	M 6	12	13,1	9,3		530	13	27
8	12	9,00	24	36	48	16,0	12,5	10,4	13	M 8	16	20,7	16,7		420	14	46
10	14	10,50	28	43	57	19,0	15,0	12,9	17	M 10	20	28,3	23,4		350	13	76
12	16	12,00	32	50	66	22,0	17,5	15,4	19	M 12	22	34,5	32,0		300	13	115
14	19	13,50	36	57	75	25,0	20,0	16,8	22	M 14	25	39,5	42,0		260	16	170
16	21	15,00	42	64	85	27,0	22,0	19,3	22	M 16	28	60,5	52,5		230	15	230
18	23	16,50	46	71	94	31,0	25,0	21,8	27	M 18x1,5	32	73,0	64,0		210	15	320
20	25	18,00	50	77	102	34,0	27,5	24,3	32	M 20x1,5	33	83,0	78,0		190	14	415
22	28	20,00	54	84	111	37,0	30,0	25,8	32	M 22x1,5	37	100,0	97,0		170	15	540
25	31	22,00	60	94	124	42,0	33,5	29,6	36	M 24x2	42	118,0	122,0		150	15	750
30	37	25,00	70	110	145	50,0	40,0	34,8	41	M 30x2	51	155,0	168,0		130	17	1130
35	43	28,00	80	125	165	58,0	46,0	37,7	50	M 36x2	56	191,0	206,0		110	19	1600
40	49	35,00	90	142	187	69,0	57,0	44,2	60	M 42x2	60	235,0	286,0		100	16	2770

Materials:

Housing: Stainless steel to 1.4057, Aisi 431, forged, polished
size 40 turned from stainless steel to 1.4057, Aisi 431

Insert: Stainless steel 1.4571 with PTFE liner bonded to the inner surface

Ball: Stainless steel 1.4034, hardened, ground, polished

This series is also available sealed (see page 52) or with threaded bolt (see page 53).

Cetop connections see page 54.

¹⁾ Size 4 on request. Housing turned from stainless steel to 1.4305, Aisi 303 / 1.4301, Aisi 304

⚠ Please note: The dynamic load "C" of the bearing of some rod ends is in some sizes higher than the static load "C₀" of the rod end.

Rod Ends Series K - Stainless, Maintenance Free

Series

GARSW..RR

Rod End with male thread and PTFE liner

For use at high dynamic pressure and tension loads in corrosive environments

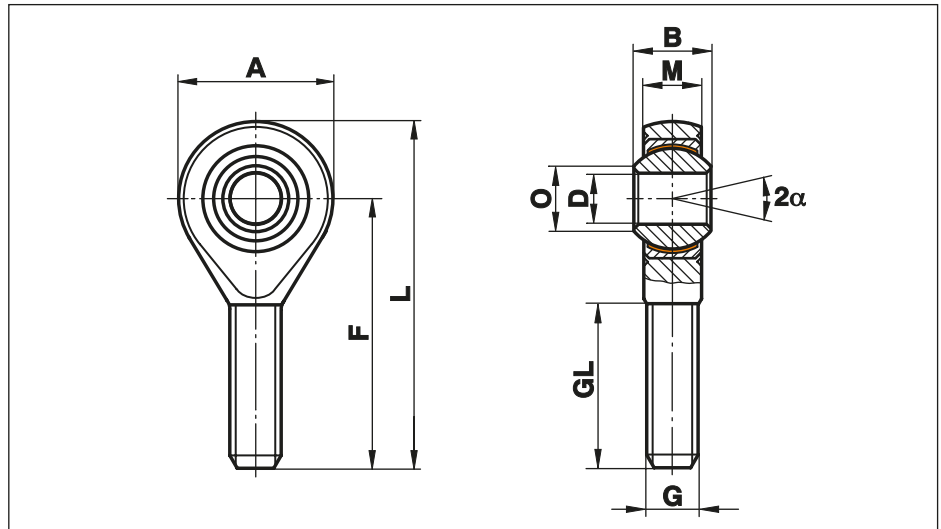

Size (D H7)	B	M	A	F	L	O	G	GL	Static load C ₀ kN	Dynamic load C kN	Limiting speed rev/min	Maximum Pivoting Angle α (°)	Weight g
4 ¹⁾	7	5,25	14	30	37	6,5	M 4	19	2,5	5,1		14	9
5	8	6,00	18	33	42	7,7	M 5	19	6,2	7,5	600	13	13
6	9	6,75	20	36	46	8,9	M 6	21	8,8	9,3	530	13	20
8	12	9,00	24	42	54	10,4	M 8	25	16,1	16,7	420	14	33
10	14	10,50	28	48	62	12,9	M 10	28	25,5	23,4	350	13	56
12	16	12,00	32	54	70	15,4	M 12	32	34,5	32,0	300	13	87
14	19	13,50	36	60	78	16,8	M 14	38	39,5	42,0	260	16	129
16	21	15,00	42	66	87	19,3	M 16	40	60,5	52,5	230	15	189
18	23	16,50	46	72	95	21,8	M 18x1,5	44	73,0	64,0	210	15	267
20	25	18,00	50	78	103	24,3	M 20x1,5	47	83,0	78,0	190	14	348
22	28	20,00	54	84	111	25,8	M 22x1,5	51	100,0	97,0	170	15	443
25	31	22,00	60	94	124	29,6	M 24x2	57	118,0	122,0	150	15	600
30	37	25,00	70	110	145	34,8	M 30x2	71	155,0	168,0	130	17	1030
35	43	28,00	80	125	165	37,7	M 36x2	73	191,0	206,0	110	19	1600
40	49	35,00	90	142	187	44,2	M 42x2	78	235,0	286,0	100	16	2570

only for short-term revolutions recommended

Materials:

Housing: Stainless steel to 1.4057, Aisi 431, forged, polished
size 40 turned from stainless steel to 1.4057, Aisi 431

Insert: Stainless steel 1.4571 with PTFE liner bonded to the inner surface

Ball: Stainless steel 1.4034, hardened, ground, polished

This series is also available sealed (see page 52) or with threaded bolt (see page 53).

¹⁾ Size 4 on request. Housing turned from stainless steel to 1.4305, Aisi 303 / 1.4301, Aisi 304

⚠ Please note: The dynamic load "C" of the bearing of some rod ends is in some sizes higher than the static load "C₀" of the rod end.

Rod Ends Series K - Stainless, Maintenance Free

Series

GIRSW..RR.316

Rod Ends with female thread and PTFE liner

For use at high dynamic pressure and tension loads in corrosive environments

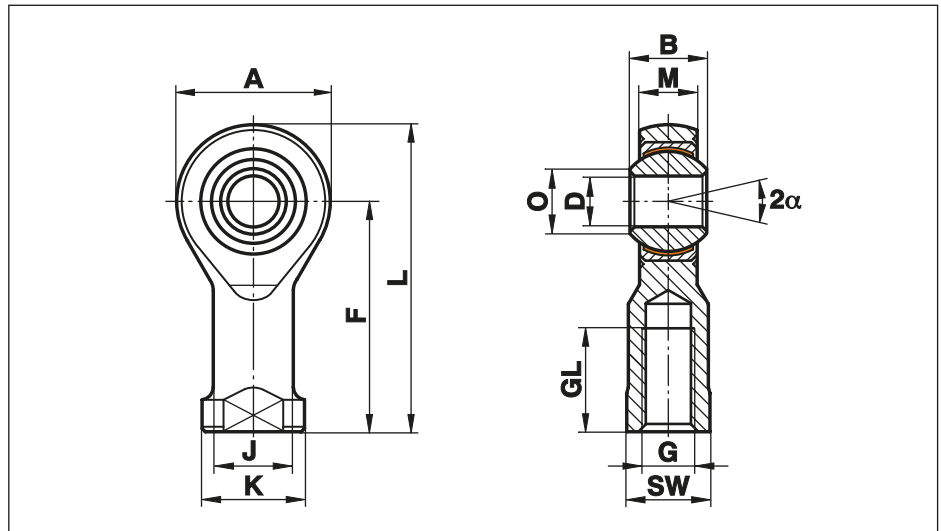

Size (D H7)	B	M	A	F	L	K	J	O	SW	G	GL	Static load C ₀ kN	Dynamic load C kN	Limiting speed rev/min	Maximum Pivoting Angle α (°)	Weight g	
4 ¹⁾	7	5,25	14	24	31	9,5	7,8	6,5	8	M 4	12	2,5	5,1	only for short-term revolutions recommended	14	11	
5	8	6,00	18	27	36	11,0	9,0	7,7	9	M 5	10	11,8	7,5		600	13	18
6	9	6,75	20	30	40	13,0	10,0	8,9	11	M 6	12	13,1	9,3		530	13	27
8	12	9,00	24	36	48	16,0	12,5	10,4	13	M 8	16	20,7	16,7		420	14	46
10	14	10,50	28	43	57	19,0	15,0	12,9	17	M 10	20	28,3	23,4		350	13	76
12	16	12,00	32	50	66	22,0	17,5	15,4	19	M 12	22	34,5	32,0		300	13	115
14	19	13,50	36	57	75	25,0	20,0	16,8	22	M 14	25	39,5	42,0		260	16	170
16	21	15,00	42	64	85	27,0	22,0	19,3	22	M 16	28	60,5	52,5		230	15	230
18	23	16,50	46	71	94	31,0	25,0	21,8	27	M 18x1,5	32	73,0	64,0		210	15	320
20	25	18,00	50	77	102	34,0	27,5	24,3	32	M 20x1,5	33	83,0	78,0		190	14	415
22	28	20,00	54	84	111	37,0	30,0	25,8	32	M 22x1,5	37	100,0	97,0		170	15	540
25	31	22,00	60	94	124	42,0	33,5	29,6	36	M 24x2	42	118,0	122,0		150	15	750
30	37	25,00	70	110	145	50,0	40,0	34,8	41	M 30x2	51	155,0	168,0		130	17	1130
35	43	28,00	80	125	165	58,0	46,0	37,7	50	M 36x2	56	191,0	206,0		110	19	1600
40	49	35,00	90	142	187	69,0	57,0	44,2	60	M 42x2	60	235,0	286,0		100	16	2770

Materials:

Housing: Stainless steel to 1.4057, Aisi 431, forged, polished
size 40 turned from stainless steel to 1.4057, Aisi 431

Insert: Stainless steel 1.4571 with PTFE liner bonded to the inner surface

Ball: Stainless steel 1.4404, ground, polished

This series is also available sealed (see page 52) or with threaded bolt (see page 53).

Cetop connections see page 54.

¹⁾ Size 4 on request. Housing turned from stainless steel to 1.4301 Aisi 304 / 1.4305, Aisi 303

⚠ Please note: The dynamic load "C" of the bearing of some rod ends is in some sizes higher than the static load "C₀" of the rod end.

Rod Ends Series K - Stainless, Maintenance Free

Series

GARSW..RR.316

Rod End with male thread and PTFE liner

For use at high dynamic pressure and tension loads in corrosive environments

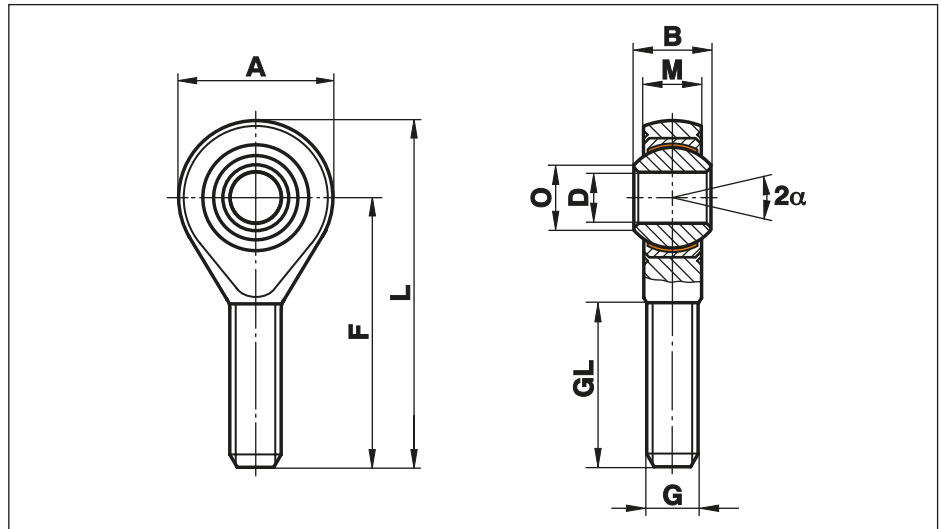

Size (D H7)	B	M	A	F	L	O	G	GL	Static load C ₀ kN	Dynamic load C kN	Limiting speed rev/min	Maximum Pivoting Angle α (°)	Weight g
4 ¹⁾	7	5,25	14	30	37	6,5	M 4	19	2,5	5,1		14	9
5	8	6,00	18	33	42	7,7	M 5	19	6,2	7,5	600	13	13
6	9	6,75	20	36	46	8,9	M 6	21	8,8	9,3	530	13	20
8	12	9,00	24	42	54	10,4	M 8	25	16,1	16,7	420	14	33
10	14	10,50	28	48	62	12,9	M 10	28	25,5	23,4	350	13	56
12	16	12,00	32	54	70	15,4	M 12	32	34,5	32,0	300	13	87
14	19	13,50	36	60	78	16,8	M 14	38	39,5	42,0	260	16	129
16	21	15,00	42	66	87	19,3	M 16	40	60,5	52,5	230	15	189
18	23	16,50	46	72	95	21,8	M 18x1,5	44	73,0	64,0	210	15	267
20	25	18,00	50	78	103	24,3	M 20x1,5	47	83,0	78,0	190	14	348
22	28	20,00	54	84	111	25,8	M 22x1,5	51	100,0	97,0	170	15	443
25	31	22,00	60	94	124	29,6	M 24x2	57	118,0	122,0	150	15	600
30	37	25,00	70	110	145	34,8	M 30x2	71	155,0	168,0	130	17	1030
35	43	28,00	80	125	165	37,7	M 36x2	73	191,0	206,0	110	19	1600
40	49	35,00	90	142	187	44,2	M 42x2	78	235,0	286,0	100	16	2570

only for short-term revolutions recommended

Materials:

Housing: Stainless steel to 1.4057, Aisi 431, forged, polished
size 40 turned from stainless steel to 1.4057, Aisi 431

Insert: Stainless steel 1.4571 with PTFE liner bonded to the inner surface

Ball: Stainless steel 1.4404, ground, polished

This series is also available sealed (see page 52) or with threaded bolt (see page 53).

¹⁾ Size 4 on request. Housing turned from stainless steel to 1.4305, Aisi 303 / 1.4301, Aisi 304

⚠ Please note: The dynamic load "C" of the bearing of some rod ends is in some sizes higher than the static load "C₀" of the rod end.

Rod Ends Series K - Stainless, Maintenance Free

Series

GIRSW..NIRO

Rod End with female thread and PTFE liner bonded to the inner surface, completely in AISI 316

For use at high dynamic pressure and tension loads in corrosive environments

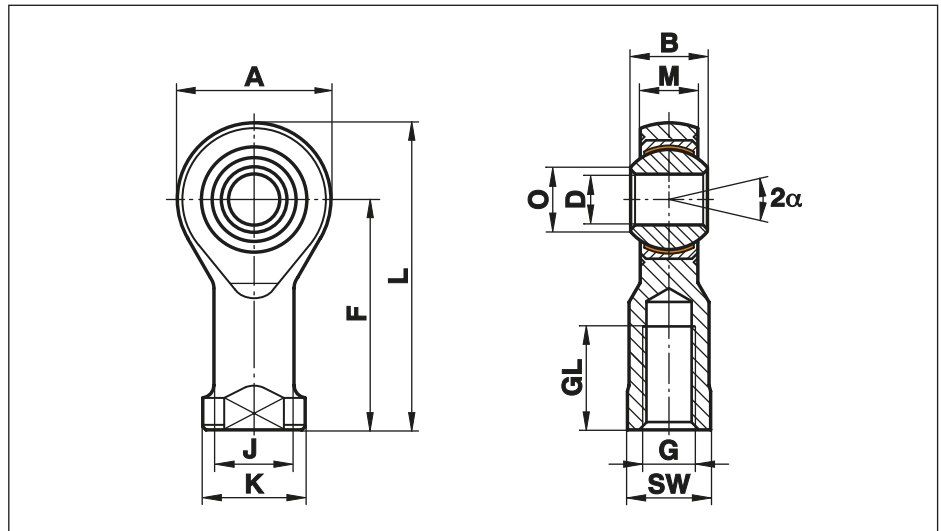

Size (D H7)	B	M	A	F	L	K	J	O	SW	G	GL	Static load C ₀ kN	Dynamic load C kN	Limiting speed rev/min	Maximum Pivoting Angle α (°)	Weight g	
4 ¹⁾	7	5,25	14	24	31	9,5	7,8	6,5	8	M 4	12	1,7	5,1	only for short-term revolutions recommended	14	11	
5	8	6,00	18	27	36	11,0	9,0	7,7	9	M 5	10	7,0	7,5		600	13	18
6	9	6,75	20	30	40	13,0	10,0	8,9	11	M 6	12	7,5	9,3		530	13	27
8	12	9,00	24	36	48	16,0	12,5	10,4	13	M 8	16	12,5	16,7		420	14	46
10	14	10,50	28	43	57	19,0	15,0	12,9	17	M 10	20	17,5	23,4		350	13	76
12	16	12,00	32	50	66	22,0	17,5	15,4	19	M 12	22	20,5	32,0		300	13	115
14	19	13,50	36	57	75	25,0	20,0	16,8	22	M 14	25	24,0	42,0		260	16	170
16	21	15,00	42	64	85	27,0	22,0	19,3	22	M 16	28	37,0	52,5		230	15	230
18	23	16,50	46	71	94	31,0	25,0	21,8	27	M 18x1,5	32	45,5	64,0		210	15	320
20	25	18,00	50	77	102	34,0	27,5	24,3	32	M 20x1,5	33	51,5	78,0		190	14	415
22	28	20,00	54	84	111	37,0	30,0	25,8	32	M 22x1,5	37	62,0	97,0		170	15	540
25	31	22,00	60	94	124	42,0	33,5	29,6	36	M 24x2	42	73,5	122,0		150	15	750
30	37	25,00	70	110	145	50,0	40,0	34,8	41	M 30x2	51	97,0	168,0		130	17	1130
35	43	28,00	80	125	165	58,0	46,0	37,7	50	M 36x2	56	121,0	206,0		110	19	1600
40	49	35,00	90	142	187	69,0	57,0	44,2	60	M 42x2	60	145,0	286,0		100	16	2770

Materials:

Housing: Stainless steel to 1.4404, Aisi 316

Insert: Stainless steel 1.4571 with PTFE liner bonded to the inner surface

Ball: Stainless steel 1.4404, Aisi316, ground, polished

This series is also available sealed (see page 52) or with threaded bolt (see page 53).

Cetop connections see page 54.

¹⁾ on request

⚠ Please note: The dynamic load "C" of the bearing of some rod ends is in some sizes higher than the static load "C₀" of the rod end.

Rod Ends Series K - Stainless, Maintenance Free

Series

GARSW..NIRO

Rod End with male thread and PTFE liner bonded to the inner surface, completely in AISI 316

For use at high dynamic pressure and tension loads in corrosive environments

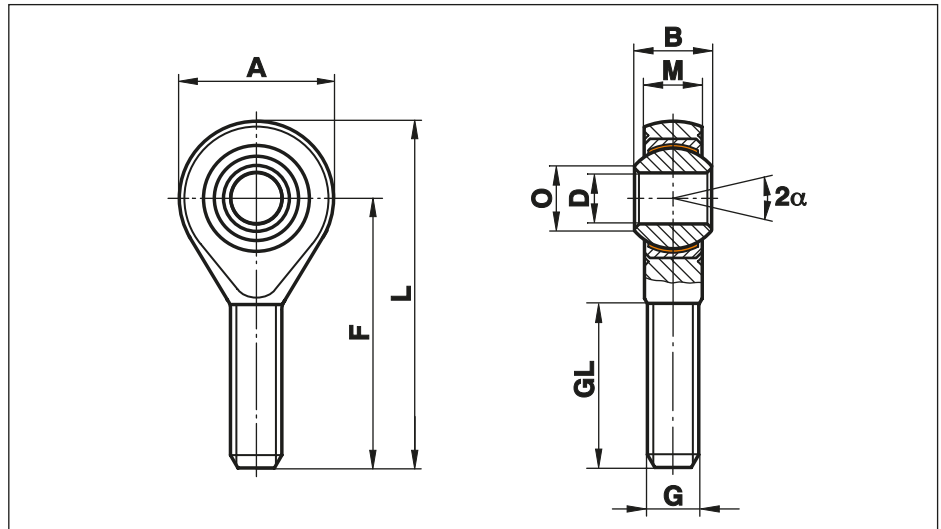

Size (D H7)	B	M	A	F	L	O	G	GL	Static load C ₀ kN	Dynamic load C kN	Limiting speed rev/min	Maximum Pivoting Angle α (°)	Weight g
4 ¹⁾	7	5,25	14	30	37	6,5	M 4	19	1,7	5,1		14	9
5	8	6,00	18	33	42	7,7	M 5	19	3,5	7,5	600	13	13
6	9	6,75	20	36	46	8,9	M 6	21	5,5	9,3	530	13	20
8	12	9,00	24	42	54	10,4	M 8	25	10,0	16,7	420	14	33
10	14	10,50	28	48	62	12,9	M 10	28	16,0	23,4	350	13	56
12	16	12,00	32	54	70	15,4	M 12	32	20,0	32,0	300	13	87
14	19	13,50	36	60	78	16,8	M 14	38	24,0	42,0	260	16	129
16	21	15,00	42	66	87	19,3	M 16	40	37,0	52,5	230	15	189
18	23	16,50	46	72	95	21,8	M 18x1,5	44	45,5	64,0	210	15	267
20	25	18,00	50	78	103	24,3	M 20x1,5	47	51,5	78,0	190	14	348
22	28	20,00	54	84	111	25,8	M 22x1,5	51	62,0	97,0	170	15	443
25	31	22,00	60	94	124	29,6	M 24x2	57	73,5	122,0	150	15	600
30	37	25,00	70	110	145	34,8	M 30x2	71	97,0	168,0	130	17	1030
35	43	28,00	80	125	165	37,7	M 36x2	73	121,5	206,0	110	19	1600
40	49	35,00	90	142	187	44,2	M 42x2	78	145,0	286,0	100	16	2570

only for short-term revolutions recommended

Materials:

Housing: Stainless steel to 1.4404, Aisi 316

Insert: Stainless steel 1.4571 with PTFE liner bonded to the inner surface

Ball: Stainless steel 1.4404, Aisi316, ground, polished

This series is also available sealed (see page 52) or with threaded bolt (see page 53).

¹⁾ on request

⚠ Please note: The dynamic load "C" of the bearing of some rod ends is in some sizes higher than the static load "C₀" of the rod end.

Rod Ends Series K - Steel on Steel

Series GIO

Rod End with female thread, without the insert

High axial load in one direction only. To be used only with limited oscillating movements

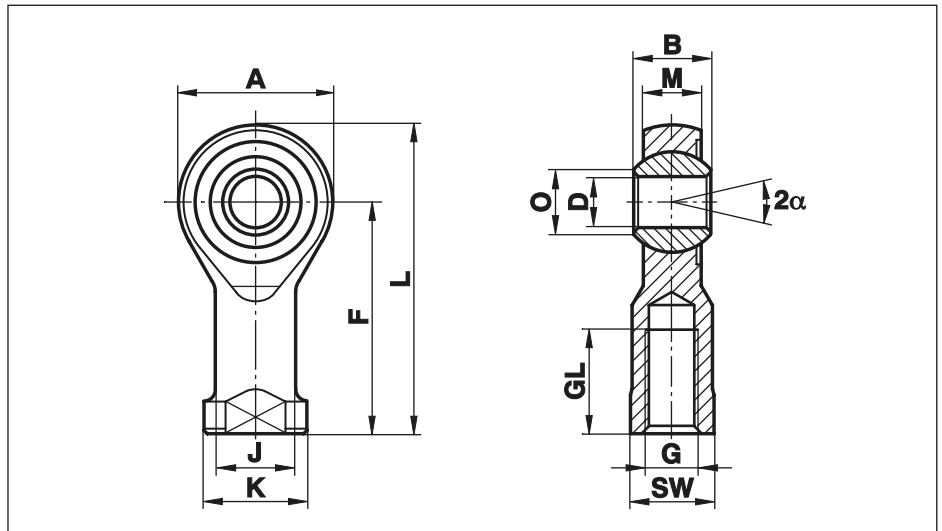

Size (D H7)	B	M	A	F	L	K	J	O	SW	G	GL	Static load C ₀ kN	Dynamic load C kN	Limiting speed rev/min	Maximum Pivoting Angle α (°)	Weight g
5	8	6,00	18	27	36	11	9,0	7,7	9	M 5	10	12,0	2,2	not to be used for complete revolutions	13	18
6	9	6,75	20	30	40	13	10,0	8,9	11	M 6	12	14,3	2,8		13	27
8	12	9,00	24	36	48	16	12,5	10,4	13	M 8	16	21,7	4,6		14	46
10	14	10,50	28	43	57	19	15,0	12,9	17	M 10	20	27,8	6,5		13	76
12	16	12,00	32	50	66	22	17,5	15,4	19	M 12	22	35,0	8,5		13	115
14	19	13,50	36	57	75	25	20,0	16,8	22	M 14	25	32,5	11,0		16	170
16	21	15,00	42	64	85	27	22,0	19,3	22	M 16	28	46,0	14,0		15	230
20	25	18,00	50	77	102	34	27,5	24,3	32	M 20x1,5	33	63,0	20,0		14	415

Materials:

Housing: up to size 12 turned, from free-cutting steel to 11SMn30+C, 12L13, galvanised from size 14 forged, from heat-treated galvanised steel to C22, M1023

Ball: Bearing steel to 100Cr6, Aisi 52100, hardened, ground, polished

Cetop connections see page 54.

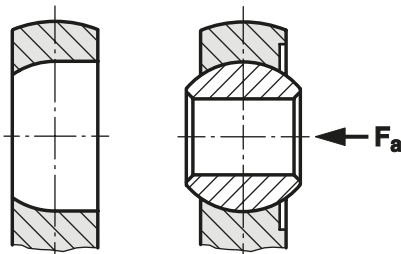

The base in the steel housing is cylindrically turned from one side and, starting from the centre line, it runs to suit the ball's contour (see drawing). Hence a high axial load towards the turned radius is possible.

 This series is not regreasable through grease nipple

Rod Ends Series K - Steel on Steel

Series GAO

Rod End with male thread, without the insert

High axial load in one direction only. To be used only with limited oscillating movements

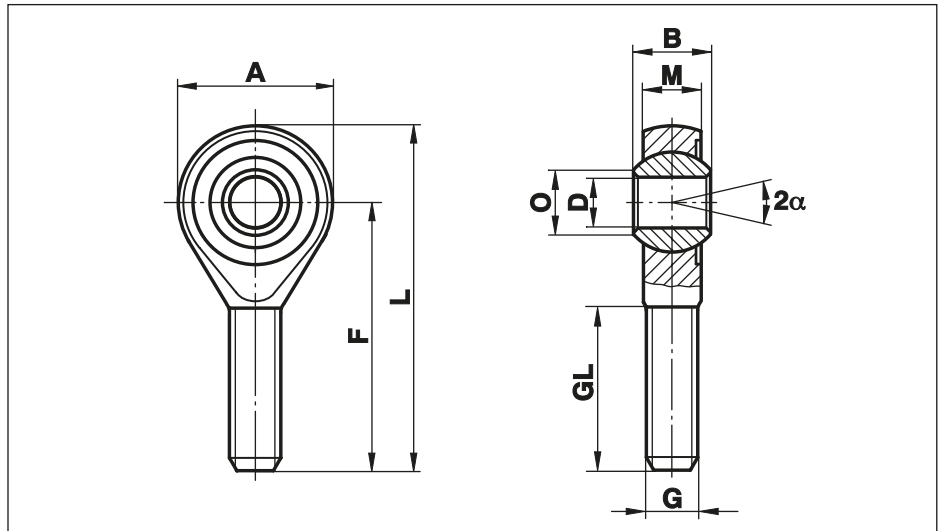

Size (D H7)	B	M	A	F	L	O	G	GL	Static load C ₀ kN	Dynamic load C kN	Limiting speed rev/min	Maximum Pivoting Angle α (°)	Weight g
5	8	6,00	18	33	42	7,7	M 5	19	4,3	2,2	not to be used for complete revolutions	13	13
6	9	6,75	20	36	46	8,9	M 6	21	6,0	2,8		13	20
8	12	9,00	24	42	54	10,4	M 8	25	11,0	4,6		14	33
10	14	10,50	28	48	62	12,9	M 10	28	17,4	6,5		13	56
12	16	12,00	32	54	70	15,4	M 12	32	25,5	8,5		13	87
14	19	13,50	36	60	78	16,8	M 14	38	26,5	11,0		16	129
16	21	15,00	42	66	87	19,3	M 16	40	36,5	14,0		15	189
20	25	18,00	50	78	103	24,3	M 20x1,5	47	63,0	20,5		14	348

Materials:

Housing: up to size 12 turned, from free-cutting steel to 11SMn30+C, 12L13, galvanised from size 14 forged, from heat-treated galvanised steel to C22, M1023

Ball: Bearing steel to 100Cr6, Aisi 52100, hardened, ground, polished

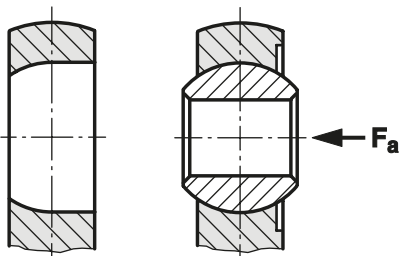

The base in the steel housing is cylindrically turned from one side and, starting from the centre line, it runs to suit the ball's contour (see drawing). Hence a high axial load towards the turned radius is possible.

⚠ This series is not regreasable through grease nipple

Rod Ends Series K - Maintenance Free

Series GIOW

Rod End with female thread, without the insert

For use in applications involving minimum axial loads and limited oscillating movements

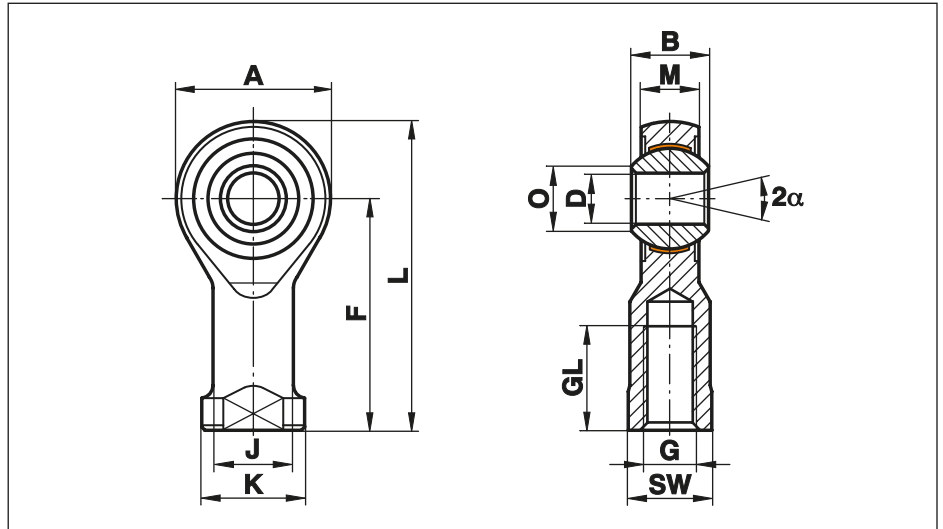

Size (D H7)	B	M	A	F	L	K	J	O	SW	G	GL	Static load C ₀ kN	Dynamic load C kN	Limiting speed rev/min	Maximum Pivoting Angle α (°)	Weight g
4	7	5,25	14	24	31	9,5	7,8	6,5	8	M 4	12	5,2	0,8	not to be used for complete revolutions	14	11
5	8	6,00	18	27	36	11,0	9,0	7,7	9	M 5	10	9,8	1,1		13	18
6	9	6,75	20	30	40	13,0	10,0	8,9	11	M 6	12	11,8	1,4		13	27
8	12	9,00	24	36	48	16,0	12,5	10,4	13	M 8	16	17,3	2,2		14	46
10	14	10,50	28	43	57	19,0	15,0	12,9	17	M 10	20	22,3	3,1		13	76
12	16	12,00	32	50	66	22,0	17,5	15,4	19	M 12	22	28,5	4,0		13	115
14	19	13,50	36	57	75	25,0	20,0	16,8	22	M 14	25	26,0	5,0		16	170
16	21	15,00	42	64	85	27,0	22,0	19,3	22	M 16	28	39,0	7,0		15	230
20	25	18,00	50	77	102	34,0	27,5	24,3	32	M 20x1,5	33	53,0	9,5	14	415	

Materials:

Housing: up to size 12 turned, from free-cutting steel to 11SMn30+C, 12L13, galvanised from size 14 forged, from heat-treated galvanised steel to C22, M1023 with PTFE liner bonded to the inner surface

Ball: Bearing steel to 100Cr6, Aisi 52100, hardened, ground, polished

Cetop connections see page 54.

Rod Ends Series K - Maintenance Free

Series GAOW

Rod End with male thread, without the insert

For use in applications involving minimum axial loads and limited oscillating movements

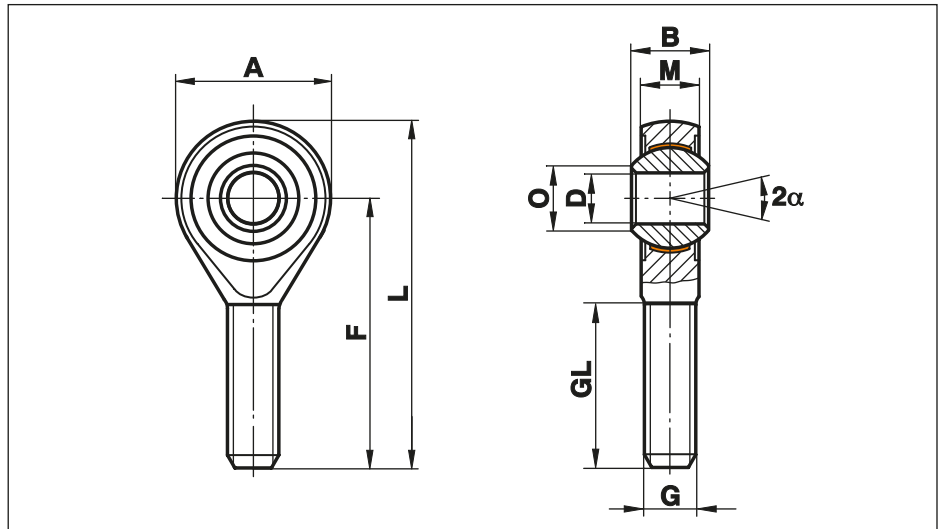

Size (D H7)	B	M	A	F	L	O	G	GL	Static load C ₀ kN	Dynamic load C kN	Limiting speed rev/min	Maximum Pivoting Angle α (°)	Weight g
4	7	5,25	14	30	37	6,5	M 4	19	2,6	0,8	not to be used for complete revolutions	14	9
5	8	6,00	18	33	42	7,7	M 5	19	4,3	1,1		13	13
6	9	6,75	20	36	46	8,9	M 6	21	6,0	1,4		13	20
8	12	9,00	24	42	54	10,4	M 8	25	11,0	2,2		14	33
10	14	10,50	28	48	62	12,9	M 10	28	17,4	3,1		13	56
12	16	12,00	32	54	70	15,4	M 12	32	25,5	4,0		13	87
14	19	13,50	36	60	78	16,8	M 14	38	26,0	5,0		16	129
16	21	15,00	42	66	87	19,3	M 16	40	36,5	7,0		15	189
20	25	18,00	50	78	103	24,3	M 20x1,5	47	53,0	9,5		14	348

Materials:

Housing: up to size 12 turned, from free-cutting steel to 11SMn30+C, 12L13, galvanised from size 14 forged, from heat-treated galvanised steel to C22, M1023 with PTFE liner bonded to the inner surface

Ball: Bearing steel to 100Cr6, Aisi 52100, hardened, ground, polished

Rod Ends Series K - Sealed Version

Series G..-2RS

Sealed Rod Ends
Series K in the following
versions:

- G.S
- G.XS
- G.RS (..R)
- G.SW
- G.XSW
- G.RSW (..R, ..RR, ..RR.316)

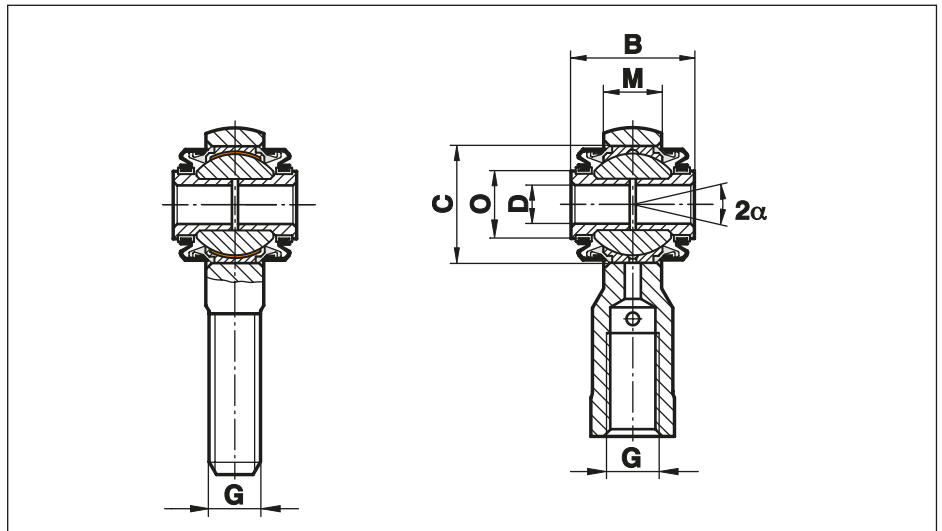

Size	D	B	M	C	O	G	Pivoting Angle α (°)
8	6	19	9,0	18,0	10,5	M 8	10
10	8	21	10,5	21,0	12,5	M 10	10
12	10	23	12,0	25,5	15,5	M 12	10
14	12	26	13,5	29,0	17,0	M 14	12
16	14	28	15,0	32,0	18,5	M 16	12
20	18	32	18,0	38,0	22,0	M 20x1,5	12

Materials:

Rod Ends: See description of respective version

2RS seals: NBR-Elastomer, temperature resistance -30° to $+120^{\circ}$ Celsius, resistant to mineral oils, grease and petrol

Retainers: Brass

Spacers: Stainless steel to 1.4305, Aisi 303

Rod Ends Series K - With Threaded Bolt

Series G..-BO

Rod Ends and Spherical Plain Bearings with threaded bolt.
For use as a right angle connector:

- G.S
- G.XS
- G.RS (..R)
- G.SW
- G.XSW
- G.RSW (..R, ..RR, ..RR.316)

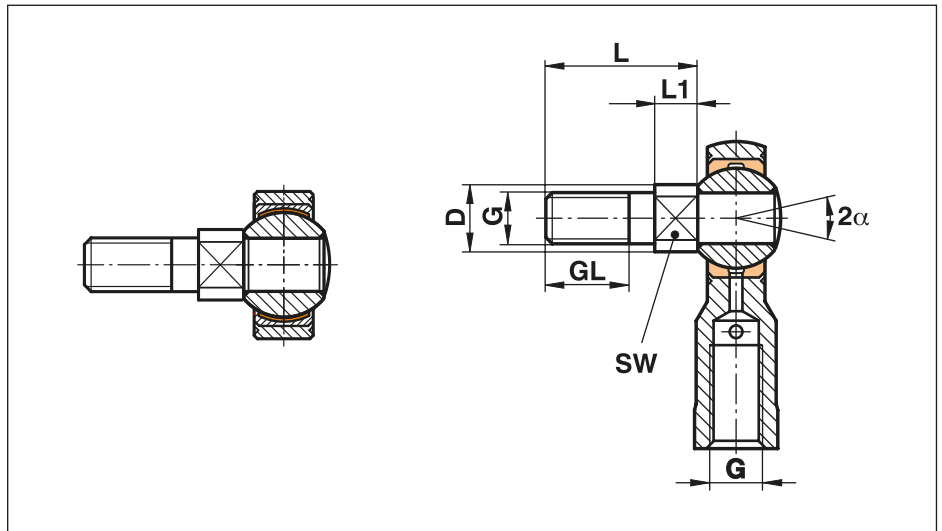

Size	L	L1	GL	G	D	SW	Weight of bolt g
5	16,0	5,0	9	M 5	7,8	7	5
6	18,5	5,5	10	M 6	9,0	8	10
8	23,5	6,5	13	M 8	10,5	8	12
10	28,0	7,0	17	M 10	13,0	12	25
12	32,5	7,5	20	M 12	15,0	14	40
14	37,5	8,5	22	M 14	17,0	14	65
16	42,5	9,5	24	M 16	19,0	17	90
20	57,0	12,0	35	M 20	24,0	22	200

Materials:

Rod Ends and Sphericals: See description of respective version

Threaded bolt: Free-cutting steel to 11SMn30+C, 12L13, zinc plated or stainless steel to 1.4305, Aisi 303

Rod Ends Series K - CETOP

Rod Ends for pneumatic cylinders to CETOP RP 103 P

All female Rod Ends series are available with CETOP dimensions for pneumatic cylinders

Connections to
ISO 8139

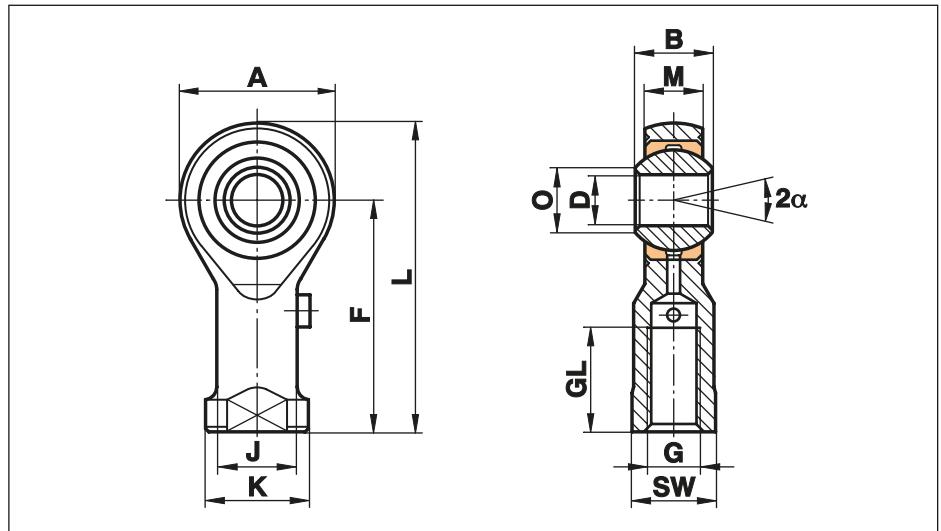

Size (D)	B	M	A	F	L	K	J	O	SW	G	GL	Static load C ₀ kN	Dynamic load C kN	Limiting speed rev/min	for cylinder-Ø
5	8	6,00	18	27	36	11	9,0	7,7	9	M 4	10				8 + 10
6	9	6,75	20	30	40	13	10,0	8,9	11	M 6	12				12 + 16
8	12	9,00	24	36	48	16	12,5	10,4	13	M 8	16				20
10	14	10,50	28	43	57	19	15,0	12,9	17	M 10x1,25	20				25 + 32
12	16	12,00	32	50	66	22	17,5	15,4	19	M 12x1,25	22				40 + 50
16	21	15,00	42	64	85	27	22,0	19,3	22	M 16x1,5	28				50 + 63
20	25	18,00	50	77	102	34	27,5	24,3	32	M 20x1,5	33				80 + 100
25	31	22,00	60	94	124	42	33,5	29,6	36	M 24x2	42				125
30	37	25,00	70	110	145	51	40,0	34,8	41	M 27x2	51				125
35	43	28,00	80	125	165	56	46,0	37,7	50	M 36x2	56				160 + 200
40	49	35,00	90	142	187	69	57,0	44,2	60	M 42x2	60				250
50	60	45,00	116	160	218	78	65,0	55,9	65	M 48x2	65				320

Materials:

See previous pages

Ordering Details:

When ordering please specify Rod Ends series and thread, for example:

GI 10x1,25

GISW 16x1,5

GIRSW 30 M27x2

Spherical Plain Bearings Series K - Standard

Series GL

Spherical Plain Bearings
with outer ring
regreasable

Especially suited for
axial loads

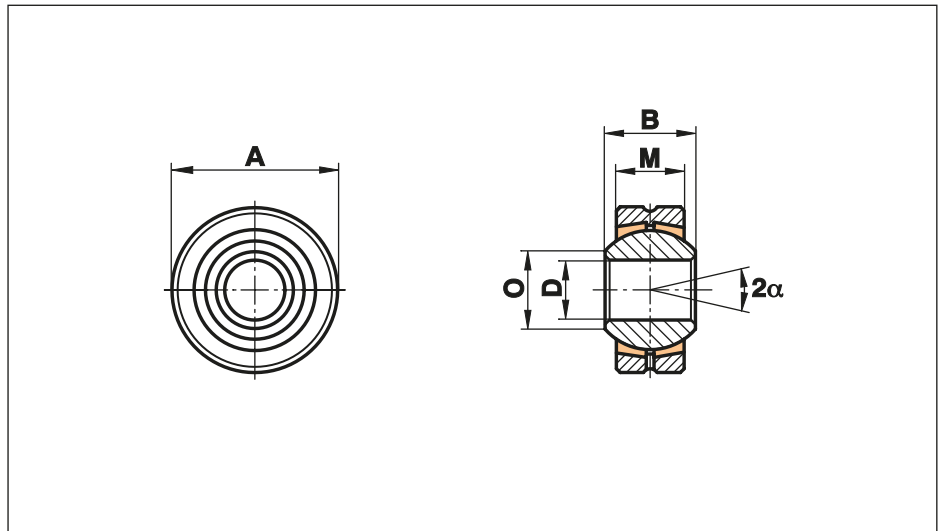

Size (D H7)	B	M	A (h6)	O	dK	Static load C ₀ kN	Dynamic load C kN	Limiting speed rev/min	Maximum Pivoting Angle α (°)	Weight g	
5	8	6,00	16	7,7	11,11	10,0	2,5	900	only for short-term revolutions recommended	13	8
6	9	6,75	18	8,9	12,70	12,8	3,2	760		13	12
8	12	9,00	22	10,4	15,87	21,6	5,4	620		14	23
10	14	10,50	26	12,9	19,05	30,0	7,5	500		13	38
12	16	12,00	30	15,4	22,22	40,0	10,0	450		13	58
14	19	13,50	34	16,8	25,40	51,5	13,0	360		16	83
16	21	15,00	38	19,3	28,57	64,5	16,0	350		15	115
18	23	16,50	42	21,8	31,75	78,5	19,5	320		15	150
20	25	18,00	46	24,3	34,92	94,5	23,5	280		14	200
22	28	20,00	50	25,8	38,10	114,0	29,0	250		15	270
25	31	22,00	56	29,6	42,86	142,0	35,0	230		15	375

Materials:

Outer ring: Free-cutting steel to 11SMn30+C, 12L13, turned, galvanised

Insert: Special brass to CuZn40Al1

Ball: Bearing steel to 100Cr6, Aisi 52100, hardened, ground, polished

Spherical Plain Bearings Series K - Heavy Duty

Series GLXS

Spherical Plain Bearing,
regreasable

For use at high revs

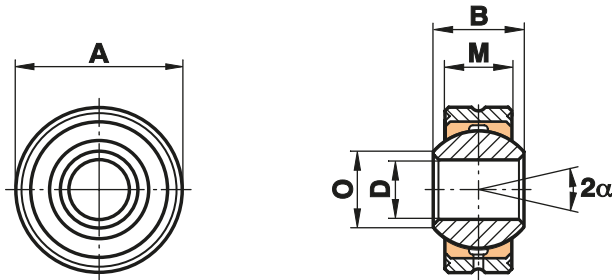

Size (D H7)	B	M	A (h6)	O	dK	Static load C ₀ kN	Dynamic load C kN	Limiting speed rev/min	Maximum Pivoting Angle α (°)	Weight g	
3 ^{1) 2)}	6	4,50	12	5,1	7,94	10,8	1,8		only for short-term revolutions recommended	14	4
4 ^{1) 2)}	7	5,25	14	6,5	9,52	14,5	2,5			14	6
5	8	6,00	16	7,7	11,11	19,8	3,3	1200		13	8
6	9	6,75	18	8,9	12,70	25,8	4,3	1500		13	12
8	12	9,00	22	10,4	15,87	42,6	7,1	1200		14	23
10	14	10,50	26	12,9	19,05	60,0	10,0	1000		13	38
12	16	12,00	30	15,4	22,22	80,0	13,5	860		13	58
14	19	13,50	34	16,8	25,40	102,5	17,0	750		16	83
16	21	15,00	38	19,3	28,57	128,5	21,5	660		15	115
18	23	16,50	42	21,8	31,75	157,0	26,0	600		15	150
20	25	18,00	46	24,3	34,92	188,5	31,5	540		14	200
22	28	20,00	50	25,8	38,10	229,0	38,0	500		15	270
25	31	22,00	56	29,6	42,86	293,0	47,0	440	15	375	
30	37	25,00	66	34,8	50,80	381,0	64,0	370	17	540	
35	43	28,00	78	37,7	57,15	480,0	80,0	330	19	850	
40	49	35,00	87	44,2	65,96	693,0	116,0	290	16	1400	

Materials:

Outer ring: Free-cutting steel to 11SMn30+C, 12L13, turned, galvanised

Insert: Special high strength bronze to CuSn8

Ball: Bearing steel to 100Cr6, Aisi 52100, hardened, ground, polished

This series is also available with threaded bolt (see page 53).

¹⁾ without lubrication hole

²⁾ Outer Ring as one piece to CuSn8

Spherical Plain Bearings - corrosion protection class III, requiring maintenance

Series GLRS

Spherical Plain Bearing,
regreasable

For use at high revs in
corrosive environments

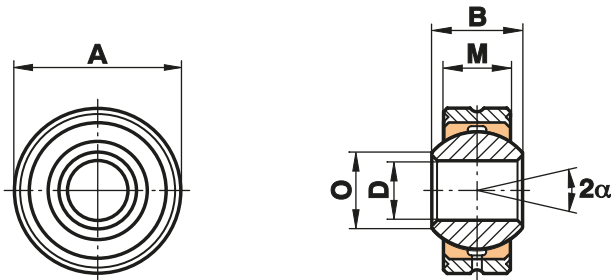

Size (D H7)	B	M	A (h6)	O	dK	Static load C ₀ kN	Dynamic load C kN	Limiting speed rev/min	Maximum Pivoting Angle α (°)	Weight g
3 ^{1) 2)}	6	4,50	12	5,1	7,94	10,8	1,8		14	5
5	8	6,00	16	7,7	11,11	19,8	3,3	1200	13	8
6	9	6,75	18	8,9	12,70	25,8	4,3	1500	13	12
8	12	9,00	22	10,4	15,87	42,6	7,1	1200	14	23
10	14	10,50	26	12,9	19,05	60,0	10,0	1000	13	38
12	16	12,00	30	15,4	22,22	80,0	13,5	860	13	58
14	19	13,50	34	16,8	25,40	102,5	17,0	750	16	83
16	21	15,00	38	19,3	28,57	128,5	21,5	660	15	115
18	23	16,50	42	21,8	31,75	157,0	26,0	600	15	150
20	25	18,00	46	24,3	34,92	188,5	31,5	540	14	200
22	28	20,00	50	25,8	38,10	229,0	38,0	500	15	270
25	31	22,00	56	29,6	42,86	293,0	47,0	440	15	375
30	37	25,00	66	34,8	50,80	381,0	64,0	370	17	540
35	43	28,00	78	37,7	57,15	480,0	80,0	330	19	850
40	49	35,00	87	44,2	45,96	693,0	116,0	290	16	1400

only for short-term revolutions recommended

Materials:

Outer ring: Stainless steel to 1.4305, Aisi 303, turned

Insert: Special high strength bronze to CuSn8

Ball: Bearing steel to 100Cr6, Aisi 52100, hardened, ground, polished, hard chrome plated on the running surface

This series is also available with threaded bolt (see page 53).

¹⁾ without lubrication hole

²⁾ Outer Ring as one piece to CuSn8

Spherical Plain Bearings series K - stainless, requiring maintenance

Series GLRS..R

Spherical Plain Bearing,
regreasable

For use at high revs in
corrosive environments

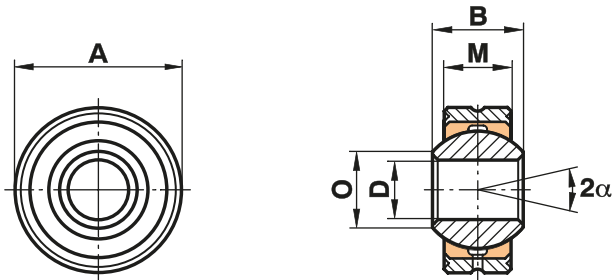

Size (D H7)	B	M	A (h6)	O	dK	Static load C ₀ kN	Dynamic load C kN	Limiting speed rev/min	Maximum Pivoting Angle α (°)	Weight g	
3 ^{1) 2)}	6	4,50	12	5,1	7,94	10,8	1,8		only for short-term revolutions recommended	14	5
5	8	6,00	16	7,7	11,11	19,8	3,3	1200		13	8
6	9	6,75	18	8,9	12,70	25,8	4,3	1500		13	12
8	12	9,00	22	10,4	15,87	42,6	7,1	1200		14	23
10	14	10,50	26	12,9	19,05	60,0	10,0	1000		13	38
12	16	12,00	30	15,4	22,22	80,0	13,5	860		13	58
14	19	13,50	34	16,8	25,40	102,5	17,0	750		16	83
16	21	15,00	38	19,3	28,57	128,5	21,5	660		15	115
18	23	16,50	42	21,8	31,75	157,0	26,0	600		15	150
20	25	18,00	46	24,3	34,92	188,5	31,5	540		14	200
22	28	20,00	50	25,8	38,10	229,0	38,0	500		15	270
25	31	22,00	56	29,6	42,86	293,0	47,0	440	15	375	
30	37	25,00	66	34,8	50,80	381,0	64,0	370	17	540	
35	43	28,00	78	37,7	57,15	480,0	80,0	330	19	850	
40	49	35,00	87	44,2	45,96	693,0	116,0	290	16	1400	

Materials:

Outer ring: Stainless steel to 1.4305, Aisi 303, turned

Insert: Special high strength bronze to CuSn8

Ball: Stainless steel 1.4034 Aisi420C, hardened, ground, polished

This series is also available with threaded bolt (see page 53).

1) not regreasable through lubrication groove

2) Outer Ring as one piece to CuSn8

Spherical Plain Bearings Series K - Maintenance Free

Series GLXSW

Spherical Plain Bearing,
maintenance free

For use at higher
dynamic pressure and
tension loads

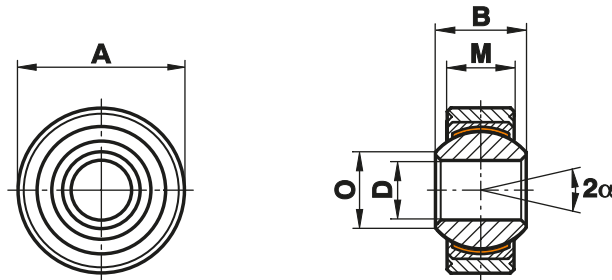

Size (D H7)	B	M	A (h6)	O	dK	Static load C ₀ kN	Dynamic load C kN	Limiting speed rev/min	Maximum Pivoting Angle α (°)	Weight g	
4 ¹⁾	7	5,25	14	6,5	9,52	9,5	5,7	700	only for short-term revolutions recommended	14	5
5	8	6,00	16	7,7	11,11	12,5	7,5	600		13	8
6	9	6,75	18	8,9	12,70	15,5	9,3	530		13	12
8	12	9,00	22	10,4	15,87	27,8	16,7	420		14	23
10	14	10,50	26	12,9	19,05	39,0	23,4	350		13	38
12	16	12,00	30	15,4	22,22	53,5	32,0	300		13	58
14	19	13,50	34	16,8	25,40	70,0	42,0	260		16	83
16	21	15,00	38	19,3	28,57	88,0	52,5	230		15	115
18	23	16,50	42	21,8	31,75	106,5	64,0	210		15	150
20	25	18,00	46	24,3	34,92	130,0	78,0	190		14	200
22	28	20,00	50	25,8	38,10	162,0	97,0	170		15	270
25	31	22,00	56	29,6	42,86	204,0	122,0	150		15	375
30	37	25,00	66	34,8	50,80	281,0	168,0	130	17	540	
35	43	28,00	78	37,7	57,15	343,0	206,0	110	19	850	
40	49	35,00	87	44,2	45,96	495,0	286,0	100	16	1400	

Materials:

Outer ring: Free-cutting steel to 11SMn30+C, 12L13, turned, galvanised

Insert: Free-cutting steel to 11SMn30+C, turned, galvanised with PTFE liner bonded to the inner surface

Ball: Bearing steel to 100Cr6, Aisi 52100, hardened, ground, polished

This series is also available with threaded bolt (see page 53).

¹⁾ Outer Ring as one piece to 45S20

Spherical Plain Bearings Series K - Stainless Outer Ring, Maintenance Free

Series GLRSW

Spherical Plain Bearing,
maintenance free

For use at higher
dynamic pressure and
tension loads in
corrosive environments

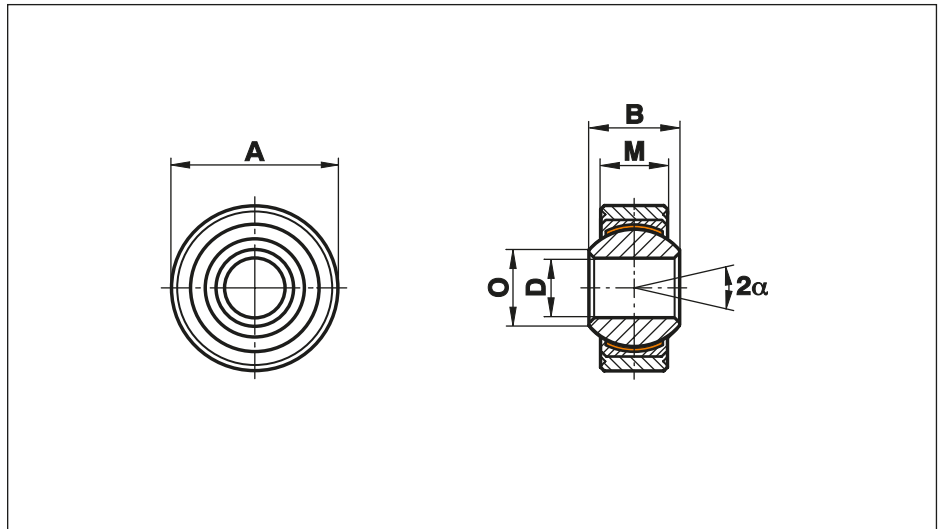

Size (D H7)	B	M	A (h6)	O	dK	Static load C ₀ kN	Dynamic load C kN	Limiting speed rev/min	Maximum Pivoting Angle α (°)	Weight g	
4 ¹⁾	7	5,25	14	6,5	9,52	9,5	5,7	700	only for short-term revolutions recommended	14	5
5	8	6,00	16	7,7	11,11	12,5	7,5	600		13	8
6	9	6,75	18	8,9	12,70	15,5	9,3	530		13	12
8	12	9,00	22	10,4	15,87	27,8	16,7	420		14	23
10	14	10,50	26	12,9	19,05	39,0	23,4	350		13	38
12	16	12,00	30	15,4	22,22	53,5	32,0	300		13	58
14	19	13,50	34	16,8	25,40	70,0	42,0	260		16	83
16	21	15,00	38	19,3	28,57	88,0	52,5	230		15	115
18	23	16,50	42	21,8	31,75	106,5	64,0	210		15	150
20	25	18,00	46	24,3	34,92	130,0	78,0	190		14	200
22	28	20,00	50	25,8	38,10	162,0	97,0	170		15	270
25	31	22,00	56	29,6	42,86	204,0	122,0	150		15	375
30	37	25,00	66	34,8	50,80	281,0	168,0	130	17	540	
35	43	28,00	78	37,7	57,15	343,0	206,0	110	19	850	
40	49	35,00	87	44,2	45,96	495,0	286,0	100	16	1400	

Materials:

Outer ring: Stainless steel to 1.4305, Aisi 303, turned

Insert: Special high strength bronze to CuSn8 with PTFE liner bonded to the inner surface

Ball: Bearing steel to 100Cr6, Aisi 52100, hardened, ground, polished, hard chrome plated on the running surface

This series is also available with threaded bolt (see page 53).

¹⁾ Outer Ring stainless steel as one piece to 1.4305, Aisi303

Spherical Plain Bearings Series K - Stainless, Maintenance Free

Series

GLRSW..R

Spherical Plain Bearing,
maintenance free

For use at higher
dynamic pressure and
tension loads in
corrosive environments

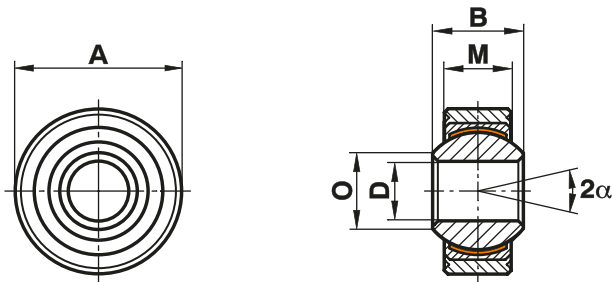

Size (D H7)	B	M	A (h6)	O	dK	Static load C ₀ kN	Dynamic load C kN	Limiting speed rev/min	Maximum Pivoting Angle α (°)	Weight g	
4 ¹⁾	7	5,25	14	6,5	9,52	9,5	5,7	700	only for short-term revolutions recommended	14	5
5	8	6,00	16	7,7	11,11	12,5	7,5	600		13	8
6	9	6,75	18	8,9	12,70	15,5	9,3	530		13	12
8	12	9,00	22	10,4	15,87	27,8	16,7	420		14	23
10	14	10,50	26	12,9	19,05	39,0	23,4	350		13	38
12	16	12,00	30	15,4	22,22	53,5	32,0	300		13	58
14	19	13,50	34	16,8	25,40	70,0	42,0	260		16	83
16	21	15,00	38	19,3	28,57	88,0	52,5	230		15	115
18	23	16,50	42	21,8	31,75	106,5	64,0	210		15	150
20	25	18,00	46	24,3	34,92	130,0	78,0	190		14	200
22	28	20,00	50	25,8	38,10	162,0	97,0	170		15	270
25	31	22,00	56	29,6	42,86	204,0	122,0	150		15	375
30	37	25,00	66	34,8	50,80	281,0	168,0	130	17	540	
35	43	28,00	78	37,7	57,15	343,0	206,0	110	19	850	
40	49	35,00	87	44,2	45,96	495,0	286,0	100	16	1400	

Materials:

Outer ring: Stainless steel to 1.4305, Aisi 303, turned

Insert: Special high strength bronze to CuSn8 with PTFE liner bonded to the inner surface

Ball: Stainless steel to 1.4034, hardened, ground, polished

This series is also available with threaded bolt (see page 53).

¹⁾ Outer Ring stainless steel as one piece to 1.4305, Aisi 303

Spherical Plain Bearings Series K - Stainless, Maintenance Free

Series

GLRSW..RR

Spherical Plain Bearing,
maintenance free

For use at higher
dynamic pressure and
tension loads in
corrosive environments

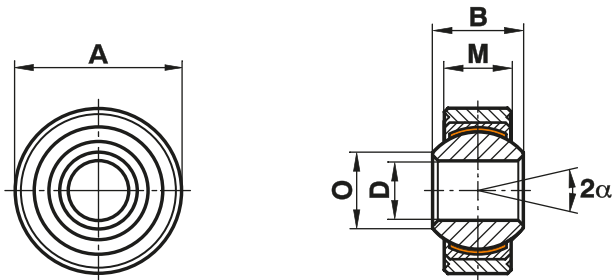

Size (D H7)	B	M	A (h6)	O	dK	Static load C ₀ kN	Dynamic load C kN	Limiting speed rev/min	Maximum Pivoting Angle α (°)	Weight g	
4 ¹⁾	7	5,25	14	6,5	9,52	9,5	5,7	700	only for short-term revolutions recommended	14	5
5	8	6,00	16	7,7	11,11	12,5	7,5	600		13	8
6	9	6,75	18	8,9	12,70	15,5	9,3	530		13	12
8	12	9,00	22	10,4	15,87	27,8	16,7	420		14	23
10	14	10,50	26	12,9	19,05	39,0	23,4	350		13	38
12	16	12,00	30	15,4	22,22	53,5	32,0	300		13	58
14	19	13,50	34	16,8	25,40	70,0	42,0	260		16	83
16	21	15,00	38	19,3	28,57	88,0	52,5	230		15	115
18	23	16,50	42	21,8	31,75	106,5	64,0	210		15	150
20	25	18,00	46	24,3	34,92	130,0	78,0	190		14	200
22	28	20,00	50	25,8	38,10	162,0	97,0	170		15	270
25	31	22,00	56	29,6	42,86	204,0	122,0	150		15	375
30	37	25,00	66	34,8	50,80	281,0	168,0	130	17	540	
35	43	28,00	78	37,7	57,15	343,0	206,0	110	19	850	
40	49	35,00	87	44,2	45,96	495,0	286,0	100	16	1400	

Materials:

Outer ring: Stainless steel to 1.4305, Aisi 303, turned

Insert: Stainless steel to 1.4571 with PTFE liner bonded to the inner surface

Ball: Stainless steel to 1.4034, hardened, ground, polished

This series is also available with threaded bolt (see page 53).

1) Outer Ring stainless steel as one piece to 1.4305, Aisi 303

Spherical Plain Bearings Series K - Stainless, Maintenance Free

Series

GLRSW..RR.316

Spherical Plain Bearing,
maintenance free

For use at higher
dynamic pressure and
tension loads in
corrosive environments

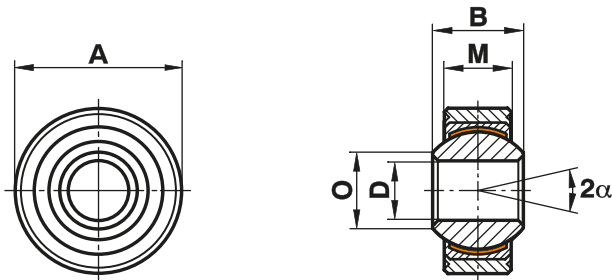

Size (D H7)	B	M	A (h6)	O	dK	Static load C ₀ kN	Dynamic load C kN	Limiting speed rev/min	Maximum Pivoting Angle α (°)	Weight g	
4 ¹⁾	7	5,25	14	6,5	9,52	9,5	5,7	700	only for short-term revolutions recommended	14	5
5	8	6,00	16	7,7	11,11	12,5	7,5	600		13	8
6	9	6,75	18	8,9	12,70	15,5	9,3	530		13	12
8	12	9,00	22	10,4	15,87	27,8	16,7	420		14	23
10	14	10,50	26	12,9	19,05	39,0	23,4	350		13	38
12	16	12,00	30	15,4	22,22	53,5	32,0	300		13	58
14	19	13,50	34	16,8	25,40	70,0	42,0	260		16	83
16	21	15,00	38	19,3	28,57	88,0	52,5	230		15	115
18	23	16,50	42	21,8	31,75	106,5	64,0	210		15	150
20	25	18,00	46	24,3	34,92	130,0	78,0	190		14	200
22	28	20,00	50	25,8	38,10	162,0	97,0	170		15	270
25	31	22,00	56	29,6	42,86	204,0	122,0	150		15	375
30	37	25,00	66	34,8	50,80	281,0	168,0	130	17	540	
35	43	28,00	78	37,7	57,15	343,0	206,0	110	19	850	
40	49	35,00	87	44,2	45,96	495,0	286,0	100	16	1400	

Materials:

Outer ring: Stainless steel to 1.4305, Aisi 303, turned

Insert: Stainless steel 1.4571 with PTFE liner bonded to the inner surface

Ball: Stainless steel to 1.4404, Aisi 316 ground, polished

This series is also available with threaded bolt (see page 53).

¹⁾ Outer Ring stainless steel as one piece to 1.4305, Aisi 303

Spherical Plain Bearings Series K - Heavy Duty

Series GXS

Spherical Plain Bearing,
regreasable

For use at high revs

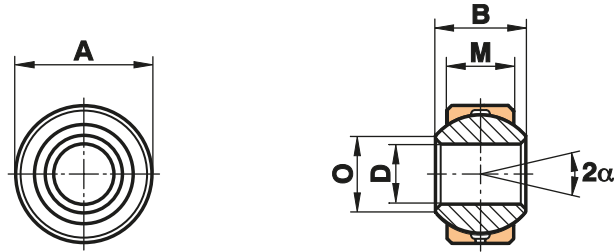

Size (D H7)	B	M	A (h6)	O	dK	Static load C ₀ kN	Dynamic load C kN	Limiting speed rev/min	Maximum Pivoting Angle α (°)	Weight g
2 ¹⁾	4,5	3,60	6,5	2,6	5,20	6,6	1,1		16	3
3 ¹⁾	6,0	4,50	9,0	5,1	7,94	10,8	1,8		14	4
4 ¹⁾	7,0	5,25	12,0	6,5	9,52	14,5	2,5		14	4
5 ¹⁾	8,0	6,00	13,0	7,7	11,11	19,8	3,3		13	5
6	9,0	6,75	15,0	8,9	12,70	25,8	4,3	1500	13	8
6.16	9,0	6,75	16,0	8,9	12,70	25,8	4,3	1500	13	9
8	12,0	9,00	18,0	10,4	15,87	42,6	7,1	1200	14	14
8.19	12,0	9,00	19,0	10,4	15,87	42,6	7,1	1200	14	16
10	14,0	10,50	21,0	12,9	19,05	60,0	10,0	1000	13	22
10.22	14,0	10,50	22,0	12,9	19,05	60,0	10,0	1000	13	25
12	16,0	12,00	24,5	15,4	22,22	80,0	13,5	860	13	35
12.26	16,0	12,00	26,0	15,4	22,22	80,0	13,5	860	13	40
14	19,0	13,50	28,0	16,8	25,40	102,5	17,0	750	16	51
14.29	19,0	13,50	29,0	16,8	25,40	102,5	17,0	750	16	56
16	21,0	15,00	31,5	19,3	28,57	128,5	21,5	660	15	72
16.32	21,0	15,00	32,0	19,3	28,57	128,5	21,5	660	15	76
18	23,0	16,50	34,5	21,8	31,75	157,0	26,0	600	15	94
18.35	23,0	16,50	35,0	21,8	31,75	157,0	26,0	600	15	97
20	25,0	18,00	38,0	24,3	34,92	188,5	31,5	540	14	124
20.40	25,0	18,00	40,0	24,3	34,92	188,5	31,5	540	14	141
22	28,0	20,00	41,0	25,8	38,10	229,0	38,0	500	15	158
22.42	28,0	20,00	42,0	25,8	38,10	229,0	38,0	500	15	168
25	31,0	22,00	46,0	29,6	42,86	293,0	47,0	440	15	218
25.47	31,0	22,00	47,0	29,6	42,86	293,0	47,0	440	15	231
30	37,0	25,00	54,0	34,8	50,80	381,0	64,0	370	17	349
30.55	37,0	25,00	55,0	34,8	50,80	381,0	64,0	370	17	362
35	43,0	28,00	62,0	37,7	57,15	480,0	80,0	330	19	502
35.65	43,0	28,00	65,0	37,7	57,15	480,0	80,0	330	19	518
40	49,0	35,00	72,0	44,2	65,96	693,0	116,0	290	16	832
40.75	49,0	35,00	75,0	44,2	65,96	693,0	116,0	290	16	850
50	60,0	45,00	90,0	55,9	82,00	1100,0	185,0	230	14	1600

only for short-term revolutions recommended

Materials:

Insert: Special high strength bronze to CuSn8

Ball: Bearing steel to 100Cr6, Aisi 52100, hardened, ground, polished

This series is also available with threaded bolt (see page 53).

¹⁾ without lubrication hole

Spherical Plain Bearings Series K - Stainless Ball, requiring maintenance

Series GXS..R

Spherical Plain Bearing,
regreasable

For use at high revs

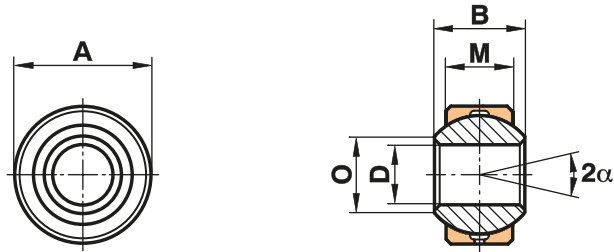

Size (D H7)	B	M	A (h6)	O	dK	Static load C ₀ kN	Dynamic load C kN	Limiting speed rev/min	Maximum Pivoting Angle α (°)	Weight g
2 ¹⁾	4,5	3,60	6,5	2,6	5,20	6,6	1,1		16	3
3 ¹⁾	6,0	4,50	9,0	5,1	7,94	10,8	1,8		14	4
4 ¹⁾	7,0	5,25	12,0	6,5	9,52	14,5	2,5		14	4
5 ¹⁾	8,0	6,00	13,0	7,7	11,11	19,8	3,3		13	5
6	9,0	6,75	15,0	8,9	12,70	25,8	4,3	1500	13	8
6.16	9,0	6,75	16,0	8,9	12,70	25,8	4,3	1500	13	9
8	12,0	9,00	18,0	10,4	15,87	42,6	7,1	1200	14	14
8.19	12,0	9,00	19,0	10,4	15,87	42,6	7,1	1200	14	16
10	14,0	10,50	21,0	12,9	19,05	60,0	10,0	1000	13	22
10.22	14,0	10,50	22,0	12,9	19,05	60,0	10,0	1000	13	25
12	16,0	12,00	24,5	15,4	22,22	80,0	13,5	860	13	35
12.26	16,0	12,00	26,0	15,4	22,22	80,0	13,5	860	13	40
14	19,0	13,50	28,0	16,8	25,40	102,5	17,0	750	16	51
14.29	19,0	13,50	29,0	16,8	25,40	102,5	17,0	750	16	56
16	21,0	15,00	31,5	19,3	28,57	128,5	21,5	660	15	72
16.32	21,0	15,00	32,0	19,3	28,57	128,5	21,5	660	15	76
18	23,0	16,50	34,5	21,8	31,75	157,0	26,0	600	15	94
18.35	23,0	16,50	35,0	21,8	31,75	157,0	26,0	600	15	97
20	25,0	18,00	38,0	24,3	34,92	188,5	31,5	540	14	124
20.40	25,0	18,00	40,0	24,3	34,92	188,5	31,5	540	14	141
22	28,0	20,00	41,0	25,8	38,10	229,0	38,0	500	15	158
22.42	28,0	20,00	42,0	25,8	38,10	229,0	38,0	500	15	168
25	31,0	22,00	46,0	29,6	42,86	293,0	47,0	440	15	218
25.47	31,0	22,00	47,0	29,6	42,86	293,0	47,0	440	15	231
30	37,0	25,00	54,0	34,8	50,80	381,0	64,0	370	17	349
30.55	37,0	25,00	55,0	34,8	50,80	381,0	64,0	370	17	362
35	43,0	28,00	62,0	37,7	57,15	480,0	80,0	330	19	502
35.65	43,0	28,00	65,0	37,7	57,15	480,0	80,0	330	19	518
40	49,0	35,00	72,0	44,2	65,96	693,0	116,0	290	16	832
40.75	49,0	35,00	75,0	44,2	65,96	693,0	116,0	290	16	850
50	60,0	45,00	90,0	55,9	82,00	1100,0	185,0	230	14	1600

only for short-term revolutions recommended

Materials:

Insert: Special high strength bronze to CuSn8

Ball: Stainless steel to 1.4034, hardened, ground, polished

This series is also available with threaded bolt (see page 53).

¹⁾ without lubrication hole

Spherical Plain Bearings Series K - Maintenance Free

Series GXSW

Spherical Plain Bearing,
maintenance free

For use at high pressure
and dynamic loads

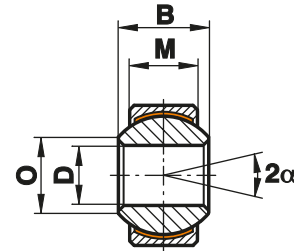
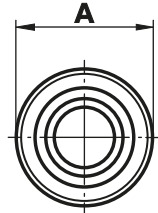

Size	D (H7)	B	M	A (h6)	O	dK	Static load C ₀ kN	Dynamic load C kN	Limiting speed rev/min	Maximum Pivoting Angle α (°)	Weight g
4	4	7	5,25	12,0	6,5	9,52	8,5	5,1	700	14	4
5	5	8	6,00	13,0	7,7	11,11	12,5	7,5	600	13	6
6	6	9	6,75	15,0	8,9	12,70	15,5	9,3	530	13	8
6.16	6	9	6,75	16,0	8,9	12,70	15,5	9,3	530	13	9
8	8	12	9,00	18,0	10,4	15,87	27,8	16,7	420	14	15
8.19	8	12	9,00	19,0	10,4	15,87	27,8	16,7	420	14	17
10	10	14	10,50	21,0	12,9	19,05	39,0	23,4	350	13	23
10.22	10	14	10,50	22,0	12,9	19,05	39,0	23,4	350	13	26
12	12	16	12,00	24,5	15,4	22,22	53,5	32,0	300	13	35
12.26	12	16	12,00	26,0	15,4	22,22	53,5	32,0	300	13	41
14	14	19	13,50	28,0	16,8	25,40	70,0	42,0	260	16	52
14.29	14	19	13,50	29,0	16,8	25,40	70,0	42,0	260	16	56
16	16	21	15,00	31,5	19,3	28,57	88,0	52,5	230	15	72
16.32	16	21	15,00	32,0	19,3	28,57	88,0	52,5	230	15	75
18	18	23	16,50	34,5	21,8	31,75	106,5	64,0	210	15	95
18.35	18	23	16,50	35,0	21,8	31,75	106,5	64,0	210	15	97
20	20	25	18,00	38,0	24,3	34,92	130,0	78,0	190	14	127
20.40	20	25	18,00	40,0	24,3	34,92	130,0	78,0	190	14	142
22	22	28	20,00	41,0	25,8	38,10	162,0	97,0	170	15	159
22.42	22	28	20,00	42,0	25,8	38,10	162,0	97,0	170	15	169
25	25	31	22,00	46,0	29,6	42,86	204,0	122,0	150	15	222
25.47	25	31	22,00	47,0	29,6	42,86	204,0	122,0	150	15	230
30	30	37	25,00	54,0	34,8	50,80	281,0	168,0	130	17	350
30.55	30	37	25,00	55,0	34,8	50,80	281,0	168,0	130	17	369
35	35	43	28,00	62,0	37,7	57,15	343,0	206,0	110	19	505
35.65	35	43	28,00	65,0	37,7	57,15	343,0	206,0	110	19	545
40	40	49	35,00	72,0	44,2	65,96	495,0	286,0	100	16	832
40.75	40	49	35,00	75,0	44,2	65,96	495,0	286,0	100	16	894
50	50	60	45,00	90,0	55,9	82,00	800,0	485,0	80	14	1640

only for short-term revolutions recommended

Materials:

Insert: Free-cutting steel to 11SMn30+C, 12L13, galvanised, with PTFE liner bonded to inner surface
Ball: Bearing steel to 100Cr6, Aisi 52100, hardened, ground, polished

This series is also available with threaded bolt (see page 53).

Spherical Plain Bearings Series K -Stainless Ball, Maintenance Free

Series GXSW..R

Spherical Plain Bearing,
maintenance free

For use at high pressure
and dynamic loads in
corrosive environments

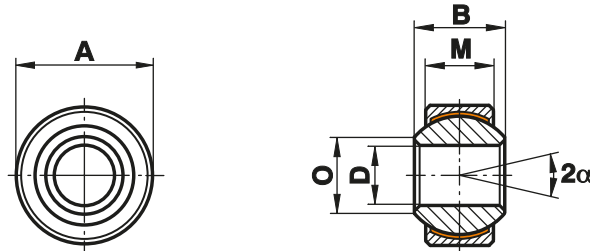

Size	D (H7)	B	M	A (h6)	O	dK	Static load C ₀ kN	Dynamic load C kN	Limiting speed rev/min	Maximum Pivoting Angle α (°)	Weight g
4	4	7	5,25	12,0	6,5	9,52	8,5	5,1	700	14	4
5	5	8	6,00	13,0	7,7	11,11	12,5	7,5	600	13	6
6	6	9	6,75	15,0	8,9	12,70	15,5	9,3	530	13	8
6.16	6	9	6,75	16,0	8,9	12,70	15,5	9,3	530	13	9
8	8	12	9,00	18,0	10,4	15,87	27,8	16,7	420	14	15
8.19	8	12	9,00	19,0	10,4	15,87	27,8	16,7	420	14	17
10	10	14	10,50	21,0	12,9	19,05	39,0	23,4	350	13	23
10.22	10	14	10,50	22,0	12,9	19,05	39,0	23,4	350	13	26
12	12	16	12,00	24,5	15,4	22,22	53,5	32,0	300	13	35
12.26	12	16	12,00	26,0	15,4	22,22	53,5	32,0	300	13	41
14	14	19	13,50	28,0	16,8	25,40	70,0	42,0	260	16	52
14.29	14	19	13,50	29,0	16,8	25,40	70,0	42,0	260	16	56
16	16	21	15,00	31,5	19,3	28,57	88,0	52,5	230	15	72
16.32	16	21	15,00	32,0	19,3	28,57	88,0	52,5	230	15	75
18	18	23	16,50	34,5	21,8	31,75	106,5	64,0	210	15	95
18.35	18	23	16,50	35,0	21,8	31,75	106,5	64,0	210	15	97
20	20	25	18,00	38,0	24,3	34,92	130,0	78,0	190	14	127
20.40	20	25	18,00	40,0	24,3	34,92	130,0	78,0	190	14	142
22	22	28	20,00	41,0	25,8	38,10	162,0	97,0	170	15	159
22.42	22	28	20,00	42,0	25,8	38,10	162,0	97,0	170	15	169
25	25	31	22,00	46,0	29,6	42,86	204,0	122,0	150	15	222
25.47	25	31	22,00	47,0	29,6	42,86	204,0	122,0	150	15	230
30	30	37	25,00	54,0	34,8	50,80	281,0	168,0	130	17	350
30.55	30	37	25,00	55,0	34,8	50,80	281,0	168,0	130	17	369
35	35	43	28,00	62,0	37,7	57,15	343,0	206,0	110	19	505
35.65	35	43	28,00	65,0	37,7	57,15	343,0	206,0	110	19	545
40	40	49	35,00	72,0	44,2	65,96	495,0	286,0	100	16	832
40.75	40	49	35,00	75,0	44,2	65,96	495,0	286,0	100	16	894
50	50	60	45,00	90,0	55,9	82,00	800,0	485,0	80	14	1640

only for short-term revolutions recommended

Materials:

Insert: Special high strength bronze to CuSn8 with PTFE liner bonded to the inner surface
Ball: Stainless steel to 1.4034, hardened, ground, polished

This series is also available with threaded bolt (see page 53).

Spherical Plain Bearings Series K -Stainless, Maintenance Free

Series

GXSW..RR

Spherical Plain Bearing,
maintenance free

For use at high pressure
and dynamic loads in
corrosive environments

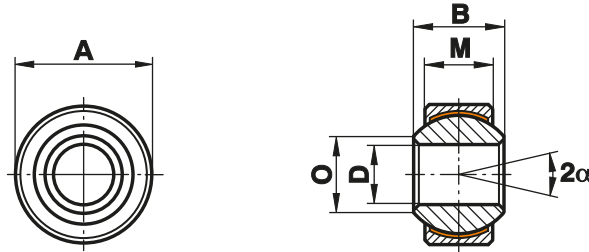

Size	D (H7)	B	M	A (h6)	O	dK	Static load C ₀ kN	Dynamic load C kN	Limiting speed rev/min	Maximum Pivoting Angle α (°)	Weight g
4	4	7	5,25	12,0	6,5	9,52	8,5	5,1	700	14	4
5	5	8	6,00	13,0	7,7	11,11	12,5	7,5	600	13	6
6	6	9	6,75	15,0	8,9	12,70	15,5	9,3	530	13	8
6.16	6	9	6,75	16,0	8,9	12,70	15,5	9,3	530	13	9
8	8	12	9,00	18,0	10,4	15,87	27,8	16,7	420	14	15
8.19	8	12	9,00	19,0	10,4	15,87	27,8	16,7	420	14	17
10	10	14	10,50	21,0	12,9	19,05	39,0	23,4	350	13	23
10.22	10	14	10,50	22,0	12,9	19,05	39,0	23,4	350	13	26
12	12	16	12,00	24,5	15,4	22,22	53,5	32,0	300	13	35
12.26	12	16	12,00	26,0	15,4	22,22	53,5	32,0	300	13	41
14	14	19	13,50	28,0	16,8	25,40	70,0	42,0	260	16	52
14.29	14	19	13,50	29,0	16,8	25,40	70,0	42,0	260	16	56
16	16	21	15,00	31,5	19,3	28,57	88,0	52,5	230	15	72
16.32	16	21	15,00	32,0	19,3	28,57	88,0	52,5	230	15	75
18	18	23	16,50	34,5	21,8	31,75	106,5	64,0	210	15	95
18.35	18	23	16,50	35,0	21,8	31,75	106,5	64,0	210	15	97
20	20	25	18,00	38,0	24,3	34,92	130,0	78,0	190	14	127
20.40	20	25	18,00	40,0	24,3	34,92	130,0	78,0	190	14	142
22	22	28	20,00	41,0	25,8	38,10	162,0	97,0	170	15	159
22.42	22	28	20,00	42,0	25,8	38,10	162,0	97,0	170	15	169
25	25	31	22,00	46,0	29,6	42,86	204,0	122,0	150	15	222
25.47	25	31	22,00	47,0	29,6	42,86	204,0	122,0	150	15	230
30	30	37	25,00	54,0	34,8	50,80	281,0	168,0	130	17	350
30.55	30	37	25,00	55,0	34,8	50,80	281,0	168,0	130	17	369
35	35	43	28,00	62,0	37,7	57,15	343,0	206,0	110	19	505
35.65	35	43	28,00	65,0	37,7	57,15	343,0	206,0	110	19	545
40	40	49	35,00	72,0	44,2	65,96	495,0	286,0	100	16	832
40.75	40	49	35,00	75,0	44,2	65,96	495,0	286,0	100	16	894
50	50	60	45,00	90,0	55,9	82,00	800,0	485,0	80	14	1640

only for short-term revolutions recommended

Materials:

Insert: Stainless steel to 1.4571 with PTFE liner bonded to the inner surface
Ball: Stainless steel to 1.4034, hardened, ground, polished

This series is also available with threaded bolt (see page 53).

Spherical Plain Bearings Series K -Stainless, Maintenance Free

Series

GXSW..RR.316

Spherical Plain Bearing,
maintenance free

For use at high pressure
and dynamic loads in
corrosive environments

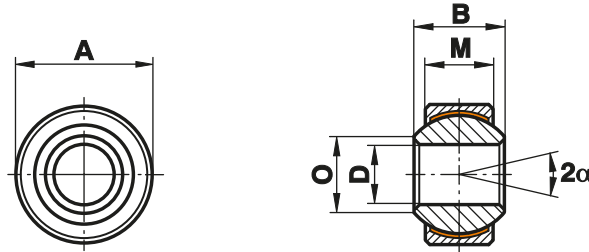

Size	D (H7)	B	M	A (h6)	O	dK	Static load C ₀ kN	Dynamic load C kN	Limiting speed rev/min	Maximum Pivoting Angle α (°)	Weight g
4	4	7	5,25	12,0	6,5	9,52	8,5	5,1	700	14	4
5	5	8	6,00	13,0	7,7	11,11	12,5	7,5	600	13	6
6	6	9	6,75	15,0	8,9	12,70	15,5	9,3	530	13	8
6.16	6	9	6,75	16,0	8,9	12,70	15,5	9,3	530	13	9
8	8	12	9,00	18,0	10,4	15,87	27,8	16,7	420	14	15
8.19	8	12	9,00	19,0	10,4	15,87	27,8	16,7	420	14	17
10	10	14	10,50	21,0	12,9	19,05	39,0	23,4	350	13	23
10.22	10	14	10,50	22,0	12,9	19,05	39,0	23,4	350	13	26
12	12	16	12,00	24,5	15,4	22,22	53,5	32,0	300	13	35
12.26	12	16	12,00	26,0	15,4	22,22	53,5	32,0	300	13	41
14	14	19	13,50	28,0	16,8	25,40	70,0	42,0	260	16	52
14.29	14	19	13,50	29,0	16,8	25,40	70,0	42,0	260	16	56
16	16	21	15,00	31,5	19,3	28,57	88,0	52,5	230	15	72
16.32	16	21	15,00	32,0	19,3	28,57	88,0	52,5	230	15	75
18	18	23	16,50	34,5	21,8	31,75	106,5	64,0	210	15	95
18.35	18	23	16,50	35,0	21,8	31,75	106,5	64,0	210	15	97
20	20	25	18,00	38,0	24,3	34,92	130,0	78,0	190	14	127
20.40	20	25	18,00	40,0	24,3	34,92	130,0	78,0	190	14	142
22	22	28	20,00	41,0	25,8	38,10	162,0	97,0	170	15	159
22.42	22	28	20,00	42,0	25,8	38,10	162,0	97,0	170	15	169
25	25	31	22,00	46,0	29,6	42,86	204,0	122,0	150	15	222
25.47	25	31	22,00	47,0	29,6	42,86	204,0	122,0	150	15	230
30	30	37	25,00	54,0	34,8	50,80	281,0	168,0	130	17	350
30.55	30	37	25,00	55,0	34,8	50,80	281,0	168,0	130	17	369
35	35	43	28,00	62,0	37,7	57,15	343,0	206,0	110	19	505
35.65	35	43	28,00	65,0	37,7	57,15	343,0	206,0	110	19	545
40	40	49	35,00	72,0	44,2	65,96	495,0	286,0	100	16	832
40.75	40	49	35,00	75,0	44,2	65,96	495,0	286,0	100	16	894
50	50	60	45,00	90,0	55,9	82,00	800,0	485,0	80	14	1640

only for short-term revolutions recommended

Materials:

Insert: Stainless steel to 1.4571 with PTFE liner bonded to the inner surface
Ball: Stainless steel to 1.4404 Aisi 316, ground, polished

This series is also available with threaded bolt (see page 53).

Spherical Plain Bearings Series E - Maintenance Free

Series GE..EC (-2RS)

Spherical Plain Bearing
maintenance free

For use at high
unidirectional radial loads

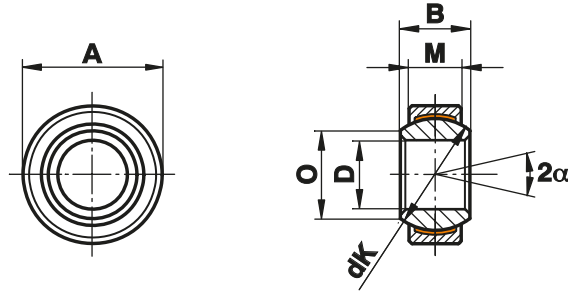

Size (D)	B	M	A	O	dK	Static load C ₀ kN	Static load C ₀ kN -2RS	Dynamic load C kN	Dynamic load C kN -2RS	Maximum Pivoting Angle α (°)	Weight g
4 ⁰ _{-0,008}	5	3	12 ⁰ _{-0,008}	6,0	8,0	5,4	-	2,1	-	16	3
5 ⁰ _{-0,008}	6	4	14 ⁰ _{-0,008}	8,0	10,0	9,1	-	3,6	-	13	4
6 ⁰ _{-0,008}	6	4	14 ⁰ _{-0,008}	8,0	10,0	9,1	-	3,6	-	13	4
8 ⁰ _{-0,008}	8	5	16 ⁰ _{-0,008}	10,2	13,0	14,0	-	5,8	-	15	7
10 ⁰ _{-0,008}	9	6	19 ⁰ _{-0,009}	13,2	16,0	21,0	-	8,6	-	12	11
12 ⁰ _{-0,008}	10	7	22 ⁰ _{-0,009}	14,9	18,0	28,0	-	11,0	-	11	17
15 ⁰ _{-0,008}	12	9	26 ⁰ _{-0,009}	18,4	22,0	45,0	59,0	18,0	17,5	8	26
16 ⁰ _{-0,008}	14	10	30 ⁰ _{-0,009}	20,7	25,0	56,0	56,0	22,0	22,5	10	40
17 ⁰ _{-0,008}	14	10	30 ⁰ _{-0,009}	20,7	25,0	56,0	75,0	22,0	22,5	10	40
20 ⁰ _{-0,010}	16	12	35 ⁰ _{-0,011}	24,1	29,0	78,0	104,0	31,0	31,5	9	64
25 ⁰ _{-0,010}	20	16	42 ⁰ _{-0,011}	29,3	35,5	127,0	204,0	51,0	51,0	7	115
30 ⁰ _{-0,010}	22	18	47 ⁰ _{-0,011}	34,2	40,7	166,0	263,0	65,0	66,0	6	149
35 ⁰ _{-0,012}	25	20	55 ⁰ _{-0,013}	39,7	47,0	211,0	338,0	84,0	140,0	6	228
40 ⁰ _{-0,012}	28	22	62 ⁰ _{-0,013}	45,0	53,0	262,0	419,0	104,0	185,0	7	318
45 ⁰ _{-0,012}	32	25	68 ⁰ _{-0,013}	50,7	60,0	337,0	540,0	135,0	240,0	7	421
50 ⁰ _{-0,012}	35	28	75 ⁰ _{-0,013}	55,9	66,0	415,0	665,0	166,0	295,0	6	562
55 ⁰ _{-0,015}	40	32	85 ⁰ _{-0,015}	62,3	74,0	-	852,0	-	355,0	7	864
60 ⁰ _{-0,015}	44	36	90 ⁰ _{-0,015}	66,8	80,0	-	1030,0	-	460,0	6	1030
70 ⁰ _{-0,015}	49	40	105 ⁰ _{-0,015}	77,8	92,0	-	1320,0	-	590,0	6	1570
80 ⁰ _{-0,015}	55	45	120 ⁰ _{-0,015}	89,4	105,0	-	1700,0	-	750,0	6	2320
90 ⁰ _{-0,020}	60	50	130 ⁰ _{-0,018}	98,1	115,0	-	2070,0	-	920,0	5	2790
100 ⁰ _{-0,020}	70	55	150 ⁰ _{-0,018}	109,5	130,0	-	2570,0	-	1145,0	7	4440
110 ⁰ _{-0,020}	70	55	160 ⁰ _{-0,025}	121,2	140,0	-	2770,0	-	1230,0	6	4830
120 ⁰ _{-0,020}	85	70	180 ⁰ _{-0,025}	135,5	160,0	-	4030,0	-	1790,0	6	8110
140 ¹⁾ _{-0,025}	90	70	210 ⁰ _{-0,030}	155,8	180,0	-	4530,0	-	2010,0	7	11200
160 ¹⁾ _{-0,025}	105	80	230 ⁰ _{-0,030}	170,2	200,0	-	5760,0	-	2560,0	8	14100
180 ¹⁾ _{-0,025}	105	80	260 ⁰ _{-0,035}	198,9	225,0	-	6480,0	-	2880,0	6	18500
200 ¹⁾ _{-0,030}	130	100	290 ⁰ _{-0,035}	213,5	250,0	-	9000,0	-	4000,0	7	28400
220 ¹⁾ _{-0,030}	135	100	320 ⁰ _{-0,040}	239,5	275,0	-	9900,0	-	4400,0	8	35700
240 ¹⁾ _{-0,030}	140	100	340 ⁰ _{-0,040}	265,3	300,0	-	10800,0	-	4800,0	8	39700
260 ¹⁾ _{-0,035}	150	110	370 ⁰ _{-0,040}	288,3	325,0	-	12870,0	-	5700,0	7	51500
280 ¹⁾ _{-0,035}	155	120	400 ⁰ _{-0,040}	313,8	350,0	-	15120,0	-	6700,0	6	64900
300 ¹⁾ _{-0,035}	165	120	430 ⁰ _{-0,045}	336,7	375,0	-	16200,0	-	7200,0	7	77600

Materials:

Insert: Bearing steel to 100Cr6, Aisi 52100, with PTFE liner, bonded to the inner surface
from size 15 available sealed from both sides (-2RS)

from size 35 only sealed from both sides (-2RS)

from size 4 to 50 when without seal, bearing steel C45/Aisi 1045 with PTFE liner, bonded to the inner surface

Ball: Bearing steel to 100Cr6, Aisi 52100, hardened, ground, polished, hard chrome plated on the running surface

¹⁾ from size 140 the hardened inserts are two pieced and secured with tension spring

FLURO®-Gelenklager GmbH

Spherical Plain Bearings Series E - Stainless, Maintenance Free

Series

GE..EC-NIRO (-2RSF)

Spherical Plain Bearing
Series E, maintenance
free

For use at high
unidirectional radial loads
in corrosive environments

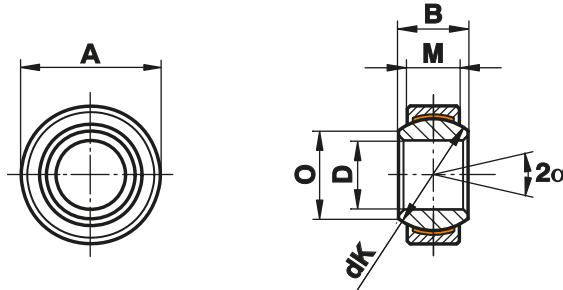

Size (D)	B	M	A	O	dK	Static load C ₀ kN	Static load C ₀ kN -2RS	Dynamic load C kN	Dynamic load C kN -2RS	Maximum Pivoting Angle α (°)	Weight g
4 ⁰ _{-0,008}	5	3	12 ⁰ _{-0,008}	6,0	8,0	5,5	-	2,5	-	16	3
5 ⁰ _{-0,008}	6	4	14 ⁰ _{-0,008}	8,0	10,0	9,0	-	4,0	-	13	4
6 ⁰ _{-0,008}	6	4	14 ⁰ _{-0,008}	8,0	10,0	9,0	-	4,0	-	13	4
8 ⁰ _{-0,008}	8	5	16 ⁰ _{-0,008}	10,2	13,0	15,6	-	7,0	-	15	7
10 ⁰ _{-0,008}	9	6	19 ⁰ _{-0,009}	13,2	16,0	23,4	-	10,0	-	12	11
12 ⁰ _{-0,008}	10	7	22 ⁰ _{-0,009}	14,9	18,0	32,0	-	14	-	11	16
15 ⁰ _{-0,008}	12	9	26 ⁰ _{-0,009}	18,4	22,0	50,0	-	30,0	-	8	26
16 ⁰ _{-0,008}	14	10	30 ⁰ _{-0,009}	20,7	25,0	65,0	-	39,0	-	10	49
17 ⁰ _{-0,008}	14	10	30 ⁰ _{-0,009}	20,7	25,0	65,0	-	39,0	-	10	38
20 ⁰ _{-0,010}	16	12	35 ⁰ _{-0,011}	24,2	29,0	90,5	-	54,0	-	9	61
25 ⁰ _{-0,010}	20	16	42 ⁰ _{-0,011}	29,3	35,5	159,0	137	96,0	78	7	110
30 ⁰ _{-0,010}	22	18	47 ⁰ _{-0,011}	34,2	40,7	197,0	155	118,0	89	6	140
35 ⁰ _{-0,012}	25	20	55 ⁰ _{-0,013}	39,8	47,0	298,0	217	153,0	124	6	220
40 ⁰ _{-0,012}	28	22	62 ⁰ _{-0,013}	45,0	53,0	370,6	276	190,0	158	7	300
45 ⁰ _{-0,012}	32	25	68 ⁰ _{-0,013}	50,8	60,0	481,0	353	247,0	202	7	400
50 ⁰ _{-0,012}	35	28	75 ⁰ _{-0,013}	56,0	66,0	598,0	457	308,0	261	6	540
60 ⁰ _{-0,015}	44	36	90 ⁰ _{-0,015}	66,8	80,0	935,0	722	481,0	413	6	1000
70 ⁰ _{-0,015}	49	40	105 ⁰ _{-0,015}	77,9	92,0	1204,0	976	619,0	558	6	1500
80 ⁰ _{-0,015}	55	45	120 ⁰ _{-0,015}	89,4	105,0	1540,0	1246	792,0	712	6	2200
90 ⁰ _{-0,020}	60	50	130 ⁰ _{-0,018}	98,1	115,0	1892,0	1525	1080,0	872	5	2700
100 ⁰ _{-0,020}	70	55	150 ⁰ _{-0,018}	109,5	130,0	2366,0	1997	1350,0	1141	7	4400
110 ⁰ _{-0,020}	70	55	160 ⁰ _{-0,025}	121,2	140,0	2548,0	2151	1460,0	1229	6	4700
120 ⁰ _{-0,020}	85	70	180 ⁰ _{-0,025}	135,5	160,0	3752,0	3186	2140,0	1821	6	8000

Materials:

- Insert:** Stainless steel to 1.4571, Aisi 316Ti, with PTFE liner bonded to the inner surface from size 80 with high performance PTFE compound from size 25 available sealed from both sides (-2RSF)
- Ball:** Stainless steel to 1.4125, Aisi 440C / 1.4112, Aisi 440B, hardened, ground, polished
- Sealing:** H Ecopur

Rod Ends Series E - Steel on Steel

Series EI (-2RS)

Rod Ends with female thread with steel on steel Spherical Plain Bearing

For use at high multi-directional loads and limited fitting dimensions

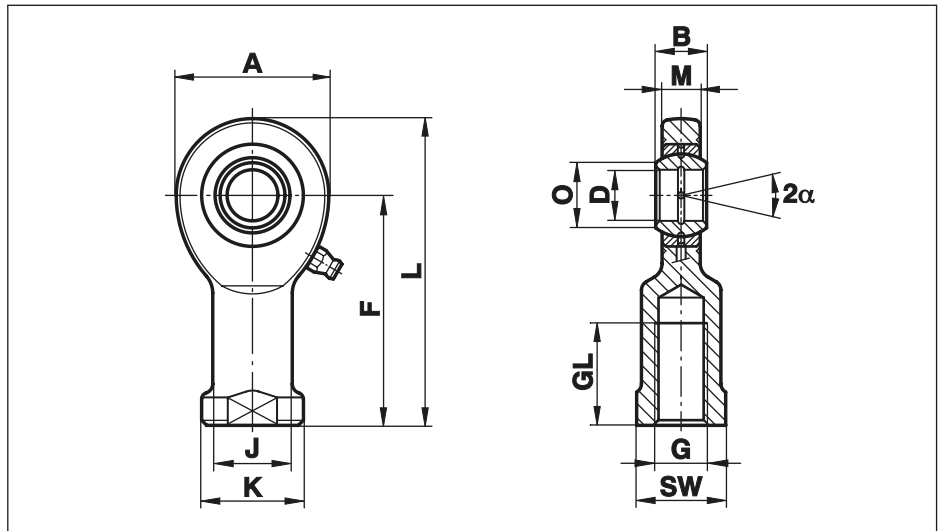

Size (D)	B	M	A	F	L	K	J	O	SW	G	GL	Static load C ₀ kN	Dynamic load C kN	Maximum Pivoting Angle α (°)	Weight g
6	6	4,4	21	30	40,0	13	10,0	8,0	11	M 6	12	10,3	3,4	13	21
8	8	6,0	24	36	48,0	16	12,5	10,2	14	M 8	16	15,8	5,5	15	38
10	9	7,0	29	43	57,0	19	15,0	13,2	17	M 10	20	23,4	8,1	12	60
12	10	8,0	34	50	67,0	22	17,5	14,9	19	M 12	23	31,0	10,8	11	96
15	12	10,0	40	61	81,0	26	21,0	18,4	22	M 14	29	42,5	17,0	8	180
16	14	11,0	46	67	90,0	30	24,0	20,7	27	M 16	33	54,5	21,2	10	220
17	14	11,0	46	67	90,0	30	24,0	20,7	27	M 16	33	54,5	21,2	10	220
20	16	13,0	53	77	103,5	35	27,5	24,2	32	M 20x1,5	40	62,5	30,0	9	350
25	20	17,0	64	94	126,0	42	33,5	29,3	36	M 24x2	48	92,0	48,0	7	640
30	22	19,0	73	110	146,5	50	40,0	34,2	41	M 30x2	56	124,0	62,0	6	930
35	25	21,0	82	125	166,0	58	47,0	39,8	50	M 36x3	60	144,0	80,0	6	1300
40	28	23,0	92	142	188,0	65	52,0	45,0	55	M 39x3	65	178,0	100,0	7	2000
40	28	23,0	92	142	188,0	65	52,0	45,0	55	M 42x3	65	102,5	99,0	7	2060
45	32	27,0	102	145	196,0	70	58,0	50,8	60	M 42x3	65	240,0	127,0	7	2500
45	32	27,0	102	145	196,0	70	58,0	50,8	60	M 45x3	65	141,0	127,0	7	2640
50	35	30,0	112	160	216,0	75	62,0	56,0	65	M 45x3	68	290,0	156,0	6	3500
50	35	30,0	112	160	216,0	75	62,0	56,0	65	M 52x3	68	140,0	156,0	6	3400
60	44	38,0	135	175	242,5	88	70,0	66,8	75	M 52x3	70	450,0	245,0	6	5550
60	44	38,0	135	175	242,5	88	70,0	66,8	75	M 60x4	70	183,0	245,0	6	5430
70	49	42,0	160	200	280,0	98	80,0	77,9	85	M 56x4	80	610,0	315,0	6	8600
70	49	42,0	160	200	280,0	98	80,0	77,9	85	M 72x4	80	306,0	313,0	6	8120
80	55	47,0	180	230	320,0	110	95,0	89,4	100	M 64x4	85	695,0	400,0	6	12000
80	55	47,0	180	230	320,0	110	95,0	89,4	100	M 80x4	85	387,0	400,0	6	12800

Materials:

Housing: up to size 10 turned, from free-cutting steel to 11SMn30+C, 12L13, galvanised
from size 12 forged from heat-treated steel to C45, Aisi 1045, galvanised

Bearing: Steel on steel bearing GE..E, requiring lubrication (see page 78)
from size 15 available sealed from both sides (-2RS)

Greasing: up to size 17 without lubrication fitting
from size 20 fitted with hydraulic grease nipples to DIN 71412

Rod Ends Series E - Steel on Steel

Series EA (-2RS)

Rod Ends with male thread with steel on steel Spherical Plain Bearings

For use at high multi-directional loads and limited fitting dimensions

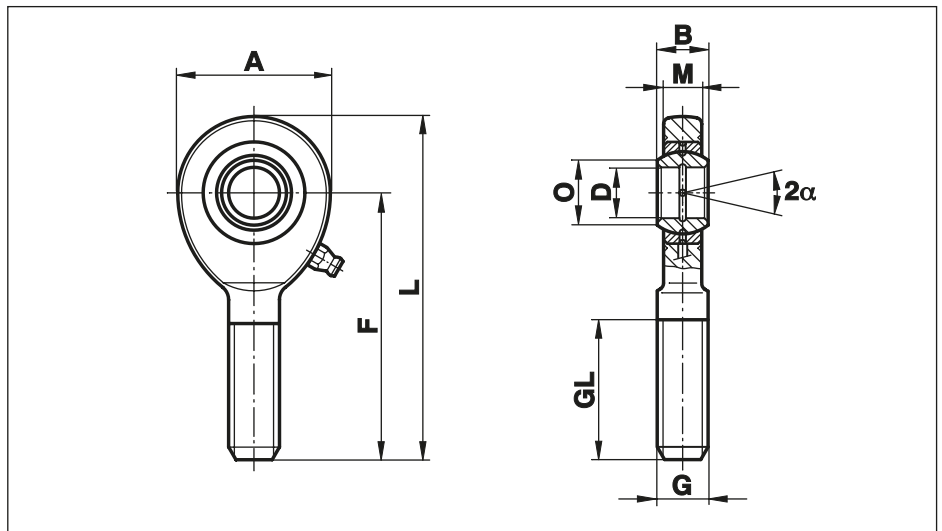

Size (D)	B	M	A	F	L	O	G	GL	Static load C ₀ kN	Dynamic load C kN	Maximum Pivoting Angle α (°)	Weight g
6	6	4,4	21	36	46,0	8,0	M 6	18	6,9	3,4	13	16
8	8	6,0	24	42	54,0	10,2	M 8	22	12,7	5,5	15	28
10	9	7,0	29	48	62,0	13,2	M 10	26	19,9	8,1	12	50
12	10	8,0	34	54	71,0	14,9	M 12	28	29,0	10,8	11	86
15	12	10,0	40	63	83,0	18,4	M 14	34	39,5	17,0	8	140
16	14	11,0	46	69	92,0	20,7	M 16	36	54,0	21,2	10	190
17	14	11,0	46	69	92,0	20,7	M 16	36	54,0	21,2	10	190
20	16	13,0	53	78	104,5	24,2	M 20x1,5	43	62,5	30,0	9	320
25	20	17,0	64	94	126,0	29,3	M 24x2	53	92,0	48,0	7	560
30	22	19,0	73	110	146,5	34,2	M 30x2	65	124,0	62,0	6	890
35	25	21,0	82	140	181,0	39,8	M 36x3	82	144,0	80,0	6	1400
40	28	23,0	92	150	196,0	45,0	M 39x3	86	178,0	100,0	7	1800
40	28	23,0	92	150	196,0	45,0	M 42x3	86	180,0	99,0	7	1850
45	32	27,0	102	163	214,0	50,8	M 42x3	94	259,0	127,0	7	2610
45	32	27,0	102	163	214,0	50,8	M 45x3	94	240,0	127,0	7	2550
50	35	30,0	112	185	241,0	56,0	M 45x3	107	313,0	156,0	6	3450
50	35	30,0	112	185	241,0	56,0	M 52x3	107	290,0	156,0	6	3650
60	44	38,0	135	210	277,5	66,8	M 52x3	115	485,0	245,0	6	5900
60	44	38,0	135	210	277,5	66,8	M 60x4	115	450,0	245,0	6	5820
70	49	42,0	160	235	315,0	77,9	M 56x4	125	564,0	315,0	6	8200
70	49	42,0	160	235	315,0	77,9	M 72x4	125	610,0	313,0	6	8080
80	55	47,0	180	270	360,0	89,4	M 64x4	140	689,0	400,0	6	12000
80	55	47,0	180	270	360,0	89,4	M 80x4	140	750,0	400,0	6	12000

Materials:

Housing: up to size 10 turned, from free-cutting steel to 11SMn30+C, 12L13, galvanised
from size 12 forged from heat-treated steel to C45, Aisi 1045, galvanised

Bearing: Steel on steel bearing GE..E, requiring lubrication (see page 78)
from size 15 available sealed from both sides (-2RS)

Greasing: up to size 17 without lubrication fitting
from size 20 fitted with hydraulic grease nipples to DIN 71412

Rod Ends Series E - Maintenance Free

Series EI..D (-2RS)

Rod End Series E with female thread, and maintenance free Spherical Plain Bearing

For use at high uni-directional loads and limited fitting dimensions

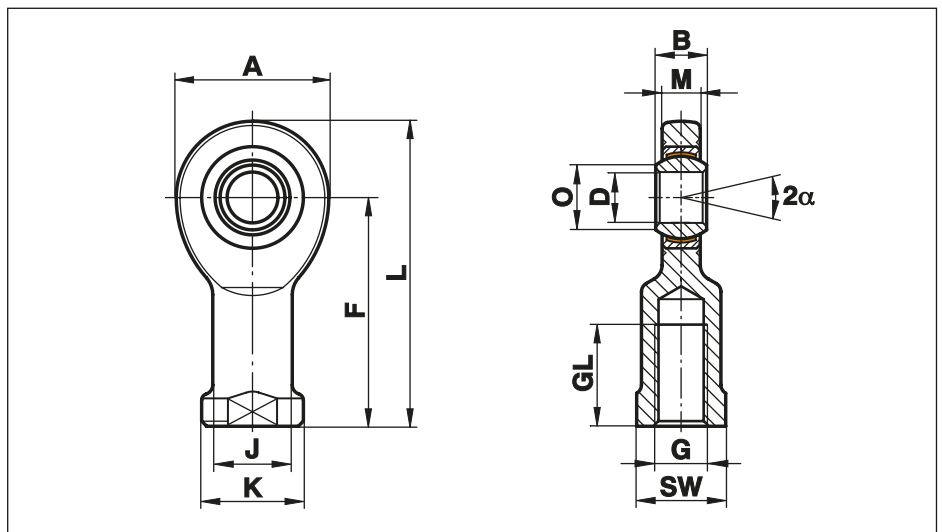

Size (D)	B	M	A	F	L	K	J	O	SW	G	GL	Static load C ₀ kN	Static load C ₀ kN -2RS	Dynamic load C kN	Dynamic load C kN -2RS	Maximum Pivoting Angle α (°)	Weight g
6	6	4,4	21	30	40,0	13	10,0	8,0	11	M 6	12	10,3	-	3,6	-	13	21
8	8	6,0	24	36	48,0	16	12,5	10,2	14	M 8	16	15,8	-	5,8	-	15	38
10	9	7,0	29	43	57,0	19	15,0	13,2	17	M 10	20	23,4	-	8,6	-	12	60
12	10	8,0	34	50	67,0	22	17,5	14,9	19	M 12	23	31,0	-	11,5	-	11	96
15	12	10,0	40	61	81,0	26	21,0	18,4	22	M 14	29	42,5	42,5	17,5	25	8	180
16	14	11,0	46	67	90,0	30	24,0	20,7	27	M 16	33	54,5	54,5	22,5	32	10	220
17	14	11,0	46	67	90,0	30	24,0	20,7	27	M 16	33	54,5	54,5	22,5	32	10	220
20	16	13,0	53	77	103,5	35	27,5	24,2	32	M 20x1,5	40	62,5	62,5	31,5	45	9	350
25	20	17,0	64	94	126,0	42	33,5	29,3	36	M 24x2	48	92,0	92,0	51,0	85	7	640
30	22	19,0	73	110	146,5	50	40,0	34,2	41	M 30x2	56	124,0	124,0	66,0	110	6	930
35	25	21,0	82	125	166,0	58	47,0	39,8	50	M 36x3	60	144,0	144,0	140,0	140	6	1300
40	28	23,0	92	142	188,0	65	52,0	45,0	55	M 39x3	65	178,0	180,0	185,0	175	7	2000
40	28	23,0	92	142	188,0	65	52,0	45,0	55	M 42x3	65	102,5	102,5	104,0	175	7	2060
45	32	27,0	102	145	196,0	70	58,0	50,8	60	M 42x3	65	240,0	240,0	240,0	225	7	2500
45	32	27,0	102	145	196,0	70	58,0	50,8	60	M 45x3	65	141,0	141,0	135,0	225	7	2640
50	35	30,0	112	160	216,0	75	62,0	56,0	65	M 45x3	68	290,0	290,0	295,0	275	6	3500
50	35	30,0	112	160	216,0	75	62,0	56,0	65	M 52x3	68	140,0	140,0	166,0	275	6	3400
60	44	38,0	135	175	242,5	88	70,0	66,8	75	M 52x3	70	450,0	450,0	460,0	430	6	5550
60	44	38,0	135	175	242,5	88	70,0	66,8	75	M 60x3	70	-	183,0	-	430	6	5430
70	49	42,0	160	200	280,0	98	80,0	77,9	85	M 56x4	80	610,0	610,0	590,0	550	6	8600
70	49	42,0	160	200	280,0	98	80,0	77,9	85	M 72x4	80	-	306,0	-	550	6	8120
80	55	47,0	180	230	320,0	110	95,0	89,4	100	M 64x4	85	695,0	750,0	750,0	705	6	12000
80	55	47,0	180	230	320,0	110	95,0	89,4	100	M 80x4	85	-	387,0	-	705	6	11800

Materials:

Housing: up to size 10 turned, from free-cutting steel to 11SMn30+C, 12L13, galvanised
from size 12 forged from heat-treated steel to C45, Aisi 1045, galvanised

Bearing: maintenance free steel/PTFE bearing GE...EC (see page 70)
from size 15 available sealed from both sides (-2RS)
from size 55 only available sealed from both sides (-2RS)

⚠ Please note: The dynamic load "C" of the bearing of some rod ends is in some sizes higher than the static load "C₀" of the rod end.

Rod Ends Series E - Maintenance Free

Series EA..D (-2RS)

Rod End Series E with male thread, and maintenance free Spherical Plain Bearing

For use at high uni-directional loads and limited fitting dimensions

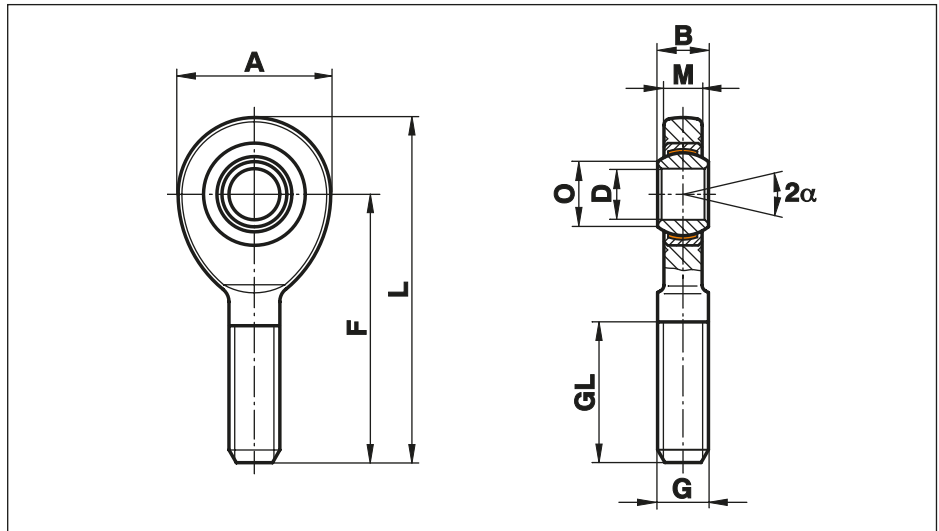

Size (D)	B	M	A	F	L	O	G	GL	Static load C ₀ kN	Static load C ₀ kN -2RS	Dynamic load C kN	Dynamic load C kN -2RS	Maximum Pivoting Angle α (°)	Weight g
6	6	4,4	21	36	46,0	8,0	M 6	18	6,9	-	3,6	-	13	16
8	8	6,0	24	42	54,0	10,2	M 8	22	12,7	-	5,8	-	15	28
10	9	7,0	29	48	62,0	13,2	M 10	26	19,9	-	8,6	-	12	50
12	10	8,0	34	54	71,0	14,9	M 12	28	29,0	-	11,5	-	11	86
15	12	10,0	40	63	83,0	18,4	M 14	34	39,5	39,5	17,5	25	8	140
16	14	11,0	46	69	92,0	20,7	M 16	36	54,0	54,0	22,5	32	10	190
17	14	11,0	46	69	92,0	20,7	M 16	36	54,0	54,0	22,5	32	10	190
20	16	13,0	53	78	104,5	24,2	M 20x1,5	43	62,5	62,5	31,5	45	9	320
25	20	17,0	64	94	126,0	29,3	M 24x2	53	92,0	92,0	51,0	85	7	560
30	22	19,0	73	110	146,5	34,2	M 30x2	65	124,0	124,0	66,0	110	6	890
35	25	21,0	82	140	181,0	39,8	M 36x3	82	144,0	144,0	140,0	140	6	1400
40	28	23,0	92	150	196,0	45,0	M 39x3	86	178,0	178,0	185,0	175	7	1800
40	28	23,0	92	150	196,0	45,0	M 42x3	86	180,0	178,0	104,0	175	7	1850
45	32	27,0	102	163	214,0	50,8	M 42x3	94	240,0	240,0	240,0	225	7	2610
45	32	27,0	102	163	214,0	50,8	M 45x3	94	240,0	240,0	135,0	225	7	2550
50	35	30,0	112	185	241,0	56,0	M 45x3	107	290,0	290,0	295,0	275	6	3450
50	35	30,0	112	185	241,0	56,0	M 52x3	107	290,0	290,0	166,0	275	6	3650
60	44	38,0	135	210	277,5	66,8	M 52x3	115	450,0	450,0	460,0	430	6	5900
60	44	38,0	135	210	277,5	66,8	M 60x4	115	-	450,0	-	430	6	5820
70	49	42,0	160	235	315,0	77,9	M 56x4	125	610,0	610,0	590,0	550	6	8200
70	49	42,0	160	235	315,0	77,9	M 72x4	125	-	610,0	-	550	6	8080
80	55	47,0	180	270	360,0	89,4	M 64x4	140	750,0	750,0	750,0	705	6	12000
80	55	47,0	180	270	360,0	89,4	M 80x4	140	-	750,0	-	705	6	12000

Materials:

Housing: up to size 10 turned, from free-cutting steel to 11SMn30+C, 12L13, galvanised
from size 12 forged from heat-treated steel to C45, Aisi 1045, galvanised

Bearing: maintenance free steel/PTFE bearing GE...EC (see page 70)
from size 15 available sealed from both sides (-2RS)
from size 55 only available sealed from both sides (-2RS)

⚠ Please note: The dynamic load "C" of the bearing of some rod ends is in some sizes higher than the static load "C₀" of the rod end.

Rod Ends Series E - Stainless, Maintenance Free

Series

EL..D-NIRO (-2RSF)

Rod End Series E
with female thread,
maintenance free
Spherical Plain Bearing
GE..EC-NIRO (-2RSF)

For use at high unidirectional loads, in corrosive environments and limited fitting dimensions

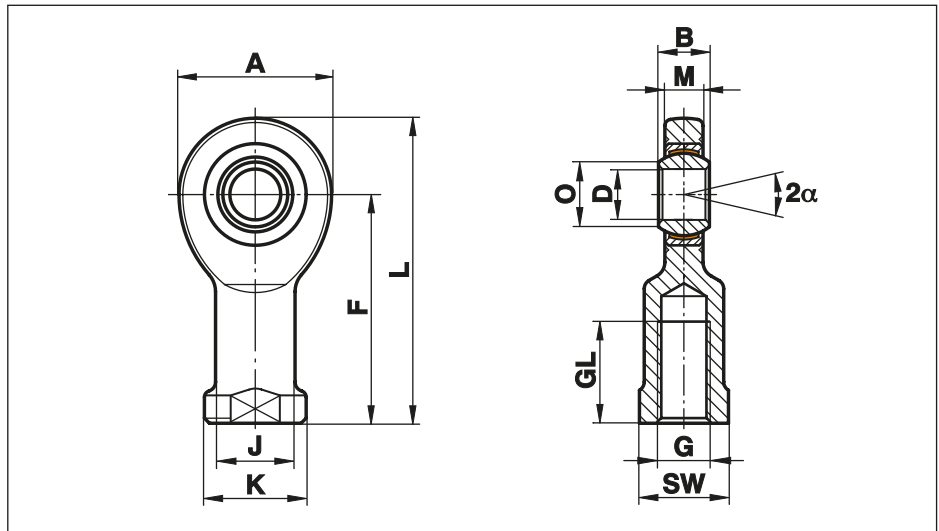

Size (D)	B	M	A	F	L	K	J	O	SW	G	GL	Static load C ₀ kN	Static load C ₀ kN -2RS	Dynamic load C kN	Dynamic load C kN -2RS	Maximum Pivoting Angle α (°)	Weight g
6	6	4,4	21	30	40,0	13	10,0	8,0	11	M 6	12	6,0	-	4	-	13	21
8	8	6,0	24	36	48,0	16	12,5	10,2	14	M 8	16	9,2	-	7	-	15	38
10	9	7,0	29	43	57,0	19	15,0	13,2	17	M 10	20	13,6	-	10	-	12	60
12	10	8,0	34	50	67,0	22	17,5	14,9	19	M 12	23	18,0	-	14	-	11	96
15	12	10,0	40	61	81,0	26	21,0	18,4	22	M 14	29	26,5	-	30	-	8	180
16	14	11,0	46	67	90,0	30	24,0	20,7	27	M 16	33	34,0	-	39	-	10	220
17	14	11,0	46	67	90,0	30	24,0	20,7	27	M 16	33	34,0	-	39	-	10	220
20	16	13,0	53	77	103,5	35	27,5	24,2	32	M 20x1,5	40	45,0	-	54	-	9	350
25	20	17,0	64	94	126,0	42	33,5	29,3	36	M 24x2	48	73,0	73	96	78	7	640
30	22	19,0	73	110	146,5	50	40,0	34,2	41	M 30x2	56	97,0	97	118	89	6	930
35	25	21,0	82	125	166,0	58	47,0	39,8	50	M 36x3	60	111,0	111	153	124	6	1300
40	28	23,0	92	142	188,0	65	52,0	45,0	55	M 39x3	65	135,0	135	190	158	7	2000
45 ¹⁾	32	27,0	102	145	196,0	70	58,0	50,8	60	M 42x3	65	178,0	178	247	202	7	2500
50	35	30,0	112	160	216,0	75	62,0	56,0	65	M 45x3	68	216,0	216	308	261	6	3500
60 ¹⁾	44	38,0	135	175	242,5	88	70,0	66,8	75	M 52x3	70	336,0	336	481	413	6	5550
70 ¹⁾	49	42,0	160	200	280,0	98	80,0	77,9	85	M 56x4	80	459,0	459	619	558	6	8600
80 ¹⁾	55	47,0	180	230	320,0	110	95,0	89,4	100	M 64x4	85	570,0	570	792	712	6	12000

Materials:

Housing: from size 6 to 40 stainless steel to 1.4301, Aisi 304, forged, polished
from size 45 stainless steel to 1.4301, Aisi 304, turned
from size 50 stainless steel to 1.4571, Aisi 316Ti, turned

Bearing: maintenance free stainless steel Spherical Plain Bearing GE...EC-NIRO (-2RSF) (see page 71)
from size 25 available sealed from both sides (-2RS)

¹⁾ availability and price on request

⚠ Please note: The dynamic load "C" of the bearing of some rod ends is in some sizes higher than the static load "C₀" of the rod end.

Rod Ends Series E - Stainless, Maintenance Free

Series

EA..D-NIRO (-2RSF)

Rod End Series E
male thread,
maintenance free
Spherical Plain Bearing
GE..EC-NIRO (-2RSF)

For use at high unidirectional loads, in corrosive environments and limited fitting dimensions

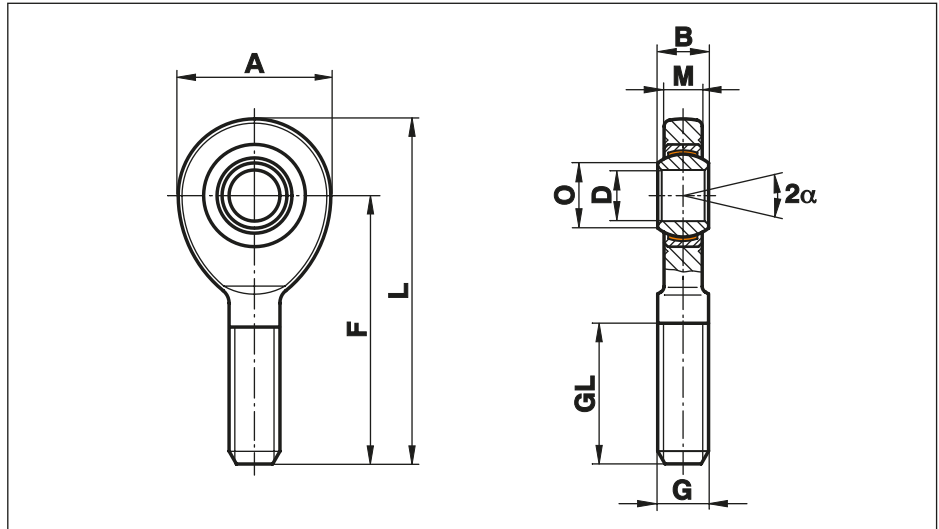

Size (D)	B	M	A	F	L	O	G	GL	Static load C ₀ kN	Static load C ₀ kN -2RS	Dynamic load C kN	Dynamic load C kN -2RS	Maximum Pivoting Angle α (°)	Weight g
6	6	4,4	21	36	46,0	8,0	M 6	18	4,0	-	4	-	13	16
8	8	6,0	24	42	54,0	10,2	M 8	22	7,4	-	7	-	15	28
10	9	7,0	29	48	62,0	13,2	M 10	26	11,6	-	10	-	12	50
12	10	8,0	34	54	71,0	14,9	M 12	28	17,0	-	14	-	11	86
15	12	10,0	40	63	83,0	18,4	M 14	34	23,0	-	30	-	8	140
16	14	11,0	46	69	92,0	20,7	M 16	36	31,5	-	39	-	10	190
17	14	11,0	46	69	92,0	20,7	M 16	36	31,5	-	39	-	10	190
20	16	13,0	53	78	104,5	24,2	M 20x1,5	43	45,0	-	54	-	9	320
25	20	17,0	64	94	126,0	29,3	M 24x2	53	73,0	73	96	78	7	570
30	22	19,0	73	110	146,5	34,2	M 30x2	65	97,0	97	118	89	6	890
35	25	21,0	82	140	181,0	39,8	M 36x3	82	111,0	111	153	124	6	1400
40	28	23,0	92	150	196,0	45,0	M 39x3	86	135,0	135	190	158	7	1800
45 ¹⁾	32	27,0	102	163	214,0	50,8	M 42x3	94	178,0	178	247	202	7	2610
50	35	30,0	112	185	241,0	56,0	M 45x3	107	216,0	216	308	261	6	3450
60 ¹⁾	44	38,0	135	210	277,5	66,8	M 52x3	115	336,0	336	481	413	6	5900
70 ¹⁾	49	42,0	160	235	315,0	77,9	M 56x4	125	429,0	429	619	558	6	8200
80 ¹⁾	55	47,0	180	270	360,0	89,4	M 64x4	140	570,0	570	792	712	6	12000

Materials:

Housing: from size 6 to 40 stainless steel to 1.4301, Aisi 304, forged, polished
from size 45 stainless steel to 1.4301, Aisi 304, turned
from size 50 stainless steel to 1.4571, Aisi 316Ti, turned

Bearing: maintenance free stainless steel Spherical Plain Bearing GE...EC-NIRO (-2RSF) (see page 71)
from size 25 available sealed from both sides (-2RS)

¹⁾ availability and price on request

Spherical Plain Bearings Series E - Steel on Steel

Series GE..E (-2RS)

Spherical Plain Bearings
steel on steel, treated
with molybdenum disulphide
mos2, regreasable

For use with high multi-
directional loads

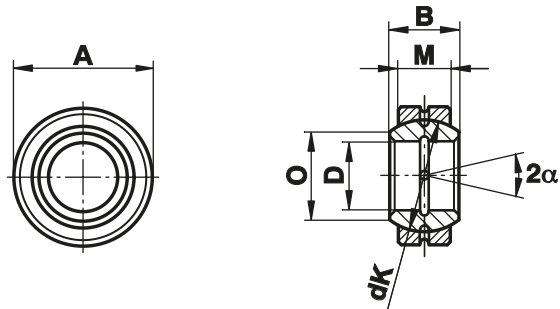

Size (D)	B	M	A	O	dK	Static load C ₀ kN	Dynamic load C kN	Maximum Pivoting Angle α (°)	Weight g
4 ¹⁾ _{-0,008}	5	3	12 _{-0,008}	6,0	8,0	10,0	2,0	16	3
5 ¹⁾ _{-0,008}	6	4	14 _{-0,008}	8,0	10,0	17,0	3,4	13	4
6 ¹⁾ _{-0,008}	6	4	14 _{-0,008}	8,0	10,0	17,0	3,4	13	4
8 ¹⁾ _{-0,008}	8	5	16 _{-0,008}	10,2	13,0	27,5	5,5	15	7
10 ¹⁾ _{-0,008}	9	6	19 _{-0,009}	13,2	16,0	40,5	8,1	12	11
12 ¹⁾ _{-0,008}	10	7	22 _{-0,009}	14,9	18,0	54,0	10,8	11	17
15 _{-0,008}	12	9	26 _{-0,009}	18,4	22,0	85,0	17,0	8	26
16 ²⁾ _{-0,008}	14	10	30 _{-0,009}	20,7	25,0	106,0	21,2	10	40
17 _{-0,008}	14	10	30 _{-0,009}	20,7	25,0	106,0	21,2	10	40
20 _{-0,010}	16	12	35 _{-0,011}	24,1	29,0	146,0	30,0	9	64
25 _{-0,010}	20	16	42 _{-0,011}	29,3	35,5	240,0	48,0	7	115
30 _{-0,010}	22	18	47 _{-0,011}	34,2	40,7	310,0	62,0	6	149
35 _{-0,012}	25	20	55 _{-0,013}	39,7	47,0	400,0	80,0	6	228
40 _{-0,012}	28	22	62 _{-0,013}	45,0	53,0	500,0	100,0	7	318
45 _{-0,012}	32	25	68 _{-0,013}	50,7	60,0	640,0	127,0	7	421
50 _{-0,012}	35	28	75 _{-0,013}	55,9	66,0	780,0	156,0	6	562
55 _{-0,015}	40	32	85 _{-0,015}	62,3	74,0	1000,0	200,0	7	864
60 _{-0,015}	44	36	90 _{-0,015}	66,8	80,0	1220,0	245,0	6	1030
70 _{-0,015}	49	40	105 _{-0,015}	77,8	92,0	1560,0	315,0	6	1570
80 _{-0,015}	55	45	120 _{-0,015}	89,4	105,0	2000,0	400,0	6	2320
90 _{-0,020}	60	50	130 _{-0,018}	98,1	115,0	2450,0	490,0	5	2790
100 _{-0,020}	70	55	150 _{-0,018}	109,5	130,0	3050,0	610,0	7	4440
110 _{-0,020}	70	55	160 _{-0,025}	121,2	140,0	3250,0	655,0	6	4830
120 _{-0,020}	85	70	180 _{-0,025}	135,5	160,0	4750,0	950,0	6	8110
140 _{-0,025}	90	70	210 _{-0,030}	155,8	180,0	5400,0	1080,0	7	11200
160 _{-0,025}	105	80	230 _{-0,030}	170,2	200,0	6800,0	1370,0	8	14100
180 _{-0,025}	105	80	260 _{-0,035}	198,9	225,0	7650,0	1530,0	6	18500
200 _{-0,030}	130	100	290 _{-0,035}	213,5	250,0	10600,0	2120,0	7	28400
220 _{-0,030}	135	100	320 _{-0,040}	239,5	275,0	11600,0	2320,0	8	35700
240 _{-0,030}	140	100	340 _{-0,040}	265,3	300,0	12700,0	2550,0	8	39700
260 _{-0,035}	150	110	370 _{-0,040}	288,3	325,0	15300,0	3050,0	7	51500
280 _{-0,035}	155	120	400 _{-0,040}	313,8	350,0	18000,0	3550,0	6	64900
300 _{-0,035}	165	120	430 _{-0,045}	336,7	375,0	19000,0	3800,0	7	77600

Materials:

Insert: Bearing steel to 100Cr6, Aisi 52100, hardened, ground, phosphated, treated with molybdenum disulphide from size 15 available sealed from both sides (-2RS)
from size 220 only available sealed from both sides (-2RS)

Ball: Bearing steel to 100Cr6, Aisi 52100, hardened, ground, phosphated, treated with molybdenum disulphide

- 1) without lubrication hole
- 2) also available with outside diameter 28 mm

FLURO®-Gelenklager GmbH

Spherical Plain Bearings - Steel on Steel

Series GE..HO-2RS

Spherical Plain Bearings steel on steel, regreasable with lip seal on both sides. Dimensions identical to series GE..E (-2RS) but ball with shoulder

Through the ball with shoulder no distance rings are required

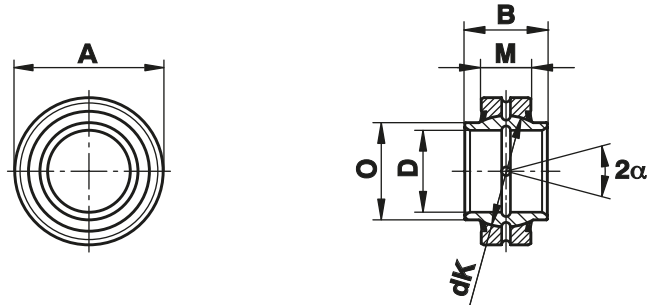

Size (D)	B	M	A	O	dK	Static load C ₀ kN	Dynamic load C kN	Maximum Pivoting Angle α (°)	Weight g
16 ²⁾ $0_{-0,008}^0$	21	10	30 $0_{-0,009}^0$	21,0	25,0	106	21,2	3	44
17 $0_{-0,008}^0$	21	10	30 $0_{-0,009}^0$	21,0	25,0	106	21,2	3	44
20 $0_{-0,010}^0$	24	12	35 $0_{-0,011}^0$	24,0	29,0	146	30,0	6	72
25 $0_{-0,010}^0$	29	16	42 $0_{-0,011}^0$	29,0	35,5	240	48,0	4	130
30 $0_{-0,010}^0$	30	18	47 $0_{-0,011}^0$	34,2	40,7	310	62,0	4	160
35 $0_{-0,012}^0$	35	20	55 $0_{-0,013}^0$	40,0	47,0	400	80,0	4	250
40 $0_{-0,012}^0$	38	22	62 $0_{-0,013}^0$	45,0	53,0	500	100,0	4	340
45 $0_{-0,012}^0$	40	25	68 $0_{-0,013}^0$	51,5	60,0	640	127,0	4	450
50 $0_{-0,012}^0$	43	28	75 $0_{-0,013}^0$	56,5	66,0	780	156,0	4	590
60 $0_{-0,015}^0$	54	36	90 $0_{-0,015}^0$	67,7	80,0	1220	245,0	3	1060
70 $0_{-0,015}^0$	65	40	105 $0_{-0,015}^0$	78,0	92,0	1560	315,0	4	1660
80 $0_{-0,015}^0$	74	45	120 $0_{-0,015}^0$	90,0	105,0	2000	400,0	4	2470
90 ¹⁾ $0_{-0,020}^0$	80	50	130 $0_{-0,018}^0$	99,0	115,0	2440	488,0	4	2880
100 ¹⁾ $0_{-0,020}^0$	90	55	150 $0_{-0,018}^0$	113,0	130,0	3030	607,0	4	4650
120 ¹⁾ $0_{-0,020}^0$	108	70	180 $0_{-0,025}^0$	133,0	160,0	4750	950,0	4	8440

Materials:

Insert: Bearing steel to 100Cr6, Aisi 52100, hardened, ground, phosphated treated with molybdenum disulphide

Ball: Bearing steel to 100Cr6, Aisi 52100, hardened, ground, phosphated treated with molybdenum disulphide

- 1) Price and availability on request
2) without -2RS seals

Spherical Plain Bearings Series E - Steel on Steel - inch-sized

Series

GE..ZO (-2RS)

Steel on Steel Spherical Plain Bearing, requiring maintenance, inch-sized

For use with high multidirectional loads

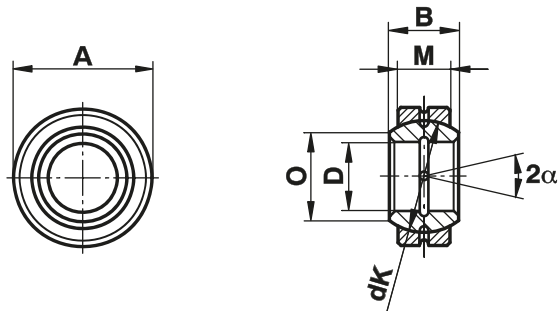

Size	D	B	M	A	dK	Static load C ₀ kN	Dynamic load C kN	Maximum Pivoting Angle α (°)	Weight g
12	12,700 ⁰ _{-0,008}	11,100	9,525	22,225 ⁰ _{-0,009}	18,000	41	13	6	22
	0,500	0,437	0,375	0,8750	0,709				
15	15,875 ⁰ _{-0,008}	13,894	11,913	26,988 ⁰ _{-0,009}	23,000	65	22	6	36
	0,625	0,547	0,469	1,0625	0,906				
19	19,050 ⁰ _{-0,010}	16,662	14,275	31,750 ⁰ _{-0,011}	27,500	95	31	6	53
	0,750	0,656	0,562	1,2500	1,083				
22	22,225 ⁰ _{-0,010}	19,431	16,662	36,513 ⁰ _{-0,011}	32,000	127	42	6	85
	0,875	0,765	0,656	1,4375	1,260				
25	25,400 ⁰ _{-0,010}	22,225	19,050	41,275 ⁰ _{-0,011}	36,500	166	56	6	121
	1,000	0,875	0,750	1,6250	1,437				
31	31,750 ⁰ _{-0,012}	27,762	23,800	50,800 ⁰ _{-0,013}	45,500	260	86	6	230
	1,250	1,093	0,937	2,0000	1,791				
34	34,925 ⁰ _{-0,012}	30,150	26,187	55,563 ⁰ _{-0,013}	49,000	310	102	5	350
	1,375	1,187	1,031	2,1875	1,929				
38	38,100 ⁰ _{-0,012}	33,325	28,575	61,913 ⁰ _{-0,013}	54,700	375	125	6	420
	1,500	1,312	1,125	2,4375	2,154				
44	44,450 ⁰ _{-0,012}	38,887	33,325	71,438 ⁰ _{-0,013}	63,900	510	170	6	640
	1,750	1,531	1,312	2,8125	2,516				
50	50,800 ⁰ _{-0,015}	44,450	38,100	80,963 ⁰ _{-0,015}	73,000	670	224	6	930
	2,000	1,750	1,500	3,1875	2,874				
57	57,150 ⁰ _{-0,015}	50,013	42,850	90,488 ⁰ _{-0,015}	82,000	850	280	6	1300
	2,250	1,969	1,687	3,5625	3,228				
63	63,500 ⁰ _{-0,015}	55,550	47,625	100,013 ⁰ _{-0,015}	92,000	1060	355	6	1850
	2,500	2,187	1,875	3,9375	3,622				
69	69,850 ⁰ _{-0,015}	61,112	52,375	111,125 ⁰ _{-0,015}	100,000	1250	415	6	2400
	2,750	2,406	2,062	4,3750	3,937				
76	76,200 ⁰ _{-0,015}	66,675	57,150	120,650 ⁰ _{-0,018}	109,500	1500	500	6	3100
	3,000	2,625	2,250	4,7500	4,311				
82	82,550 ⁰ _{-0,020}	72,238	61,900	130,175 ⁰ _{-0,018}	119,000	1760	585	6	3800
	3,250	2,844	2,437	5,1250	4,685				
88	88,900 ⁰ _{-0,020}	77,775	66,675	139,700 ⁰ _{-0,018}	128,000	2040	680	6	4800
	3,500	3,062	2,625	5,5000	5,039				
95	95,250 ⁰ _{-0,020}	83,337	71,425	149,225 ⁰ _{-0,015}	137,000	2360	780	6	5800
	3,750	3,281	2,812	5,8750	5,394				

Spherical Plain Bearings Series E - Steel on Steel - inch-sized

Size	D	B	M	A	dK	Static load C ₀ kN	Dynamic load C kN	Maximum Pivoting Angle α (°)	Weight g
101	101,60 ⁰ _{-0,020}	88,900	76,200	158,750 ⁰ _{-0,025}	146,000	2650	900	6	7000
	4,00	3,500	3,000	6,250	5,748				
107	107,95 ⁰ _{-0,020}	94,463	80,950	168,275 ⁰ _{-0,025}	155,000	3000	1000	6	8400
	4,25	3,719	3,187	6,625	6,102				
114	114,30 ⁰ _{-0,020}	100,013	85,725	177,800 ⁰ _{-0,025}	164,500	3400	1120	6	9800
	4,50	3,937	3,375	7,000	6,476				
120	120,65 ⁰ _{-0,025}	105,562	90,475	187,325 ⁰ _{-0,030}	173,500	3750	1250	6	11500
	4,75	4,156	3,562	7,375	6,831				
127	127,00 ⁰ _{-0,025}	111,125	95,250	196,850 ⁰ _{-0,030}	183,000	4150	1400	6	13500
	5,00	4,375	3,750	7,750	7,205				
152	152,40 ⁰ _{-0,025}	120,650	104,775	222,250 ⁰ _{-0,030}	207,000	5200	1730	5	17500
	6,00	4,750	4,125	8,750	8,150				
165	165,10 ⁰ _{-0,025}	123,825	103,175	247,650 ⁰ _{-0,030}	223,000	5500	1830	7	22900
	6,50	4,875	4,062	9,750	8,780				
177	177,80 ⁰ _{-0,025}	133,350	111,125	266,700 ⁰ _{-0,035}	240,000	6390	2120	7	28600
	7,00	5,250	4,375	10,500	9,449				
190	190,50 ⁰ _{-0,030}	142,875	119,050	285,750 ⁰ _{-0,035}	257,000	7340	2440	7	35100
	7,50	5,625	4,687	11,250	10,118				
203	203,50 ⁰ _{-0,030}	152,400	127,000	304,800 ⁰ _{-0,035}	275,000	8350	2770	7	42600
	8,00	6,000	5,000	12,000	10,827				
215	215,90 ⁰ _{-0,030}	161,925	134,925	323,850 ⁰ _{-0,040}	292,000	9420	3130	7	51100
	8,50	6,375	5,312	12,750	11,496				
228	228,60 ⁰ _{-0,030}	171,450	142,750	342,900 ⁰ _{-0,040}	309,000	10500	3510	7	60700
	9,00	6,750	5,625	13,500	12,165				
241	241,30 ⁰ _{-0,030}	180,975	150,800	361,950 ⁰ _{-0,040}	326,000	11700	3910	7	71400
	9,50	7,125	5,937	14,250	12,835				
254	254,00 ⁰ _{-0,035}	190,500	158,750	381,000 ⁰ _{-0,040}	343,000	13050	4340	7	83300
	10,00	7,500	6,250	15,000	13,504				
266	266,70 ⁰ _{-0,035}	200,250	166,675	400,050 ⁰ _{-0,045}	360,000	14300	4780	7	96400
	10,50	7,875	6,562	15,750	14,173				
279	279,40 ⁰ _{-0,035}	209,550	174,625	419,100 ⁰ _{-0,045}	377,000	15700	5250	7	110800
	11,00	8,250	6,875	16,500	14,843				
292	292,10 ⁰ _{-0,035}	219,075	182,550	438,150 ⁰ _{-0,045}	395,000	17200	5740	7	126700
	11,50	8,625	7,187	17,250	15,551				
304	304,80 ⁰ _{-0,035}	288,600	190,500	457,200 ⁰ _{-0,045}	412,000	18700	6250	7	143900
	12,00	9,000	7,500	18,000	16,220				

Materials:

Insert: Bearing steel to 100Cr6, Aisi 52100, hardened, ground, phosphated treated with molybdenum disulphide from size 19 available sealed from both sides (-2RS)

Ball: Bearing steel to 100Cr6, Aisi 52100, hardened, ground, phosphated treated with molybdenum disulphide

Spherical Plain Bearings Series W - Steel on Steel

Series GE..LO

Spherical Plain Bearings
steel on steel series W
to DIN ISO 12240-1,
treated with molyb-
denum disulphide mos2,
regreasable

For use on standard
Hydraulic Cylinders to
DIN 24333 and to DIN
24336 with floor piece
or piston rod relays

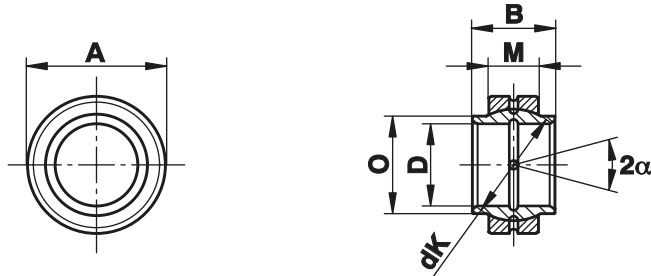

Size (D)	B	M	A	O	dK	Static load C ₀ kN	Dynamic load C kN	Maximum Pivoting Angle α (°)	Weight g
12 ¹⁾ _{+0,018} ⁰	12	7	22 _{-0,009} ⁰	15,5	18,0	54	10,8	4	17
15 _{+0,018} ⁰	15	9	26 _{-0,009} ⁰	18,5	22,0	84	16,0	5	28
16 _{+0,018} ⁰	16	9	28 _{-0,009} ⁰	20,0	23,0	88	17,6	4	34
17 _{+0,018} ⁰	17	10	30 _{-0,011} ⁰	21,0	25,0	106	21,0	7	43
20 _{+0,021} ⁰	20	12	35 _{-0,011} ⁰	25,0	29,0	146	30,0	4	69
25 _{+0,021} ⁰	25	16	42 _{-0,011} ⁰	30,5	35,5	240	48,0	4	124
30 _{+0,021} ⁰	30	18	47 _{-0,011} ⁰	34,0	40,7	310	62,0	4	159
32 _{+0,025} ⁰	32	18	52 _{-0,013} ⁰	37,0	43,0	335	67,0	4	207
35 _{+0,025} ⁰	35	20	55 _{-0,013} ⁰	40,0	47,0	399	79,0	4	248
40 _{+0,025} ⁰	40	22	62 _{-0,013} ⁰	46,0	53,0	500	100,0	4	349
45 _{+0,025} ⁰	45	25	68 _{-0,013} ⁰	52,0	60,0	637	127,0	4	468
50 _{+0,025} ⁰	50	28	75 _{-0,013} ⁰	57,0	66,0	780	156,0	4	620
60 _{+0,030} ⁰	60	36	90 _{-0,015} ⁰	68,0	80,0	1220	245,0	4	1110
63 _{+0,030} ⁰	63	36	95 _{-0,015} ⁰	71,5	83,0	1270	255,0	4	1270
70 _{+0,030} ⁰	70	40	105 _{-0,015} ⁰	79,0	92,0	1560	315,0	4	1690
80 _{+0,030} ⁰	80	45	120 _{-0,015} ⁰	91,0	105,0	2000	400,0	4	2550
90 _{+0,035} ⁰	90	50	130 _{-0,018} ⁰	99,0	115,0	2450	490,0	4	3040
100 _{+0,035} ⁰	100	55	150 _{-0,018} ⁰	113,0	130,0	3050	610,0	4	4870
110 _{+0,035} ⁰	110	55	160 _{-0,025} ⁰	124,0	140,0	3250	655,0	4	5530
125 _{+0,040} ⁰	125	70	180 _{-0,025} ⁰	138,0	160,0	4750	950,0	4	8190
160 _{+0,040} ⁰	160	80	230 _{-0,030} ⁰	177,0	200,0	6800	1370,0	4	15800
200 _{+0,046} ⁰	200	100	290 _{-0,035} ⁰	221,0	250,0	10600	2120,0	4	31700
250 _{+0,046} ⁰	250	120	400 _{-0,040} ⁰	317,0	350,0	18000	3550,0	4	101000
320 _{+0,057} ⁰	320	160	520 _{-0,050} ⁰	405,0	450,0	30500	6100,0	4	225000

Materials:

Insert: Bearing steel to 100Cr6, Aisi 52100, hardened, ground, phosphated treated with molybdenum disulphide

Ball: Bearing steel to 100Cr6, Aisi 52100, hardened, ground, phosphated treated with molybdenum disulphide

¹⁾ lubrication groove in the insert only

Spherical Plain Bearings Series G - Steel on Steel

Series GE..FO (-2RS)

Spherical Plain Bearings
steel on steel series G
to DIN ISO 12240-1.
Treated with molybdenum disulphide mos2,
regreasable

For use with higher
pivoting angle

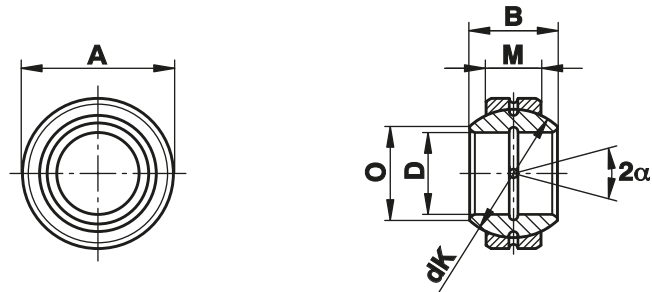

Size (D)	B	M	A	O	dK	Static load C ₀ kN	Dynamic load C kN	Maximum Pivoting Angle α (°)	Weight g
4 ¹⁾ _{-0,008}	7	4	14 _{-0,008}	7,1	10,0	17,0	3,4	20	5
5 ¹⁾ _{-0,008}	9	5	16 _{-0,008}	9,3	13,0	27,0	5,5	21	8
6 ¹⁾ _{-0,008}	9	5	16 _{-0,008}	9,3	13,0	27,5	5,5	21	8
8 ¹⁾ _{-0,008}	11	6	19 _{-0,009}	11,6	16,0	40,5	8,1	21	14
10 ¹⁾ _{-0,008}	12	7	22 _{-0,009}	13,4	18,0	54,0	10,8	18	21
12 ¹⁾ _{-0,008}	15	9	26 _{-0,009}	16,0	22,0	85,0	17,0	18	36
15 _{-0,008}	16	10	30 _{-0,009}	19,2	25,0	106,0	21,2	16	48
17 _{-0,008}	20	12	35 _{-0,011}	21,0	29,0	146,0	30,0	19	80
20 _{-0,010}	25	16	42 _{-0,011}	25,2	35,5	240,0	48,0	17	152
25 _{-0,010}	28	18	47 _{-0,011}	29,5	40,7	310,0	62,0	17	199
30 _{-0,010}	32	20	55 _{-0,013}	34,4	47,0	400,0	80,0	17	296
35 _{-0,012}	35	22	62 _{-0,013}	39,7	53,0	500,0	100,0	16	402
40 _{-0,012}	40	25	68 _{-0,013}	44,7	60,0	640,0	127,0	17	535
45 _{-0,012}	43	28	75 _{-0,013}	50,0	66,0	780,0	156,0	15	698
50 _{-0,012}	56	36	90 _{-0,015}	57,1	80,0	1220,0	245,0	17	1420
60 _{-0,015}	63	40	105 _{-0,015}	67,0	92,0	1560,0	315,0	17	2090
70 _{-0,015}	70	45	120 _{-0,015}	78,2	105,0	2000,0	400,0	16	3010
80 _{-0,015}	75	50	130 _{-0,018}	87,1	115,0	2450,0	490,0	14	3610
90 _{-0,020}	85	55	150 _{-0,018}	98,3	130,0	3050,0	610,0	15	5500
100 _{-0,020}	85	55	160 _{-0,025}	111,2	140,0	3250,0	655,0	14	6040
110 _{-0,020}	100	70	180 _{-0,025}	124,8	160,0	4750,0	950,0	12	9740
120 _{-0,020}	115	70	210 _{-0,030}	138,4	180,0	5400,0	1080,0	16	15100
140 _{-0,025}	130	80	230 _{-0,030}	151,9	200,0	6800,0	1370,0	16	18900
160 _{-0,025}	135	80	260 _{-0,035}	180,0	225,0	7650,0	1530,0	16	24800
180 _{-0,025}	155	100	290 _{-0,035}	196,1	250,0	10600,0	2120,0	14	35900
200 _{-0,030}	165	100	320 _{-0,040}	220,0	275,0	11600,0	2320,0	15	44900
220 _{-0,030}	175	100	340 _{-0,040}	243,6	300,0	12700,0	2550,0	16	50900
240 _{-0,030}	190	110	370 _{-0,040}	263,6	325,0	15300,0	3050,0	15	65300
260 _{-0,035}	205	120	400 _{-0,040}	283,6	350,0	18000,0	3550,0	15	82000
280 _{-0,035}	210	120	430 _{-0,045}	310,6	375,0	19000,0	3800,0	15	96600

Materials:

Insert:

Bearing steel to 100Cr6, Aisi 52100, hardened, ground, phosphated
treated with molybdenum disulphide
from size 15 available sealed from both sides (-2RS)

¹⁾ without lubrication hole

Ball:

Bearing steel to 100Cr6, Aisi 52100, hardened, ground, phosphated
treated with molybdenum disulphide

Spherical Plain Bearings Series G - Maintenance Free

Series GE..FW (-2RS)

Spherical Plain Bearings series G to DIN ISO 12240-1. Mating surface hard chromium/PTFE, maintenance free

Higher pivoting angle through wider ball

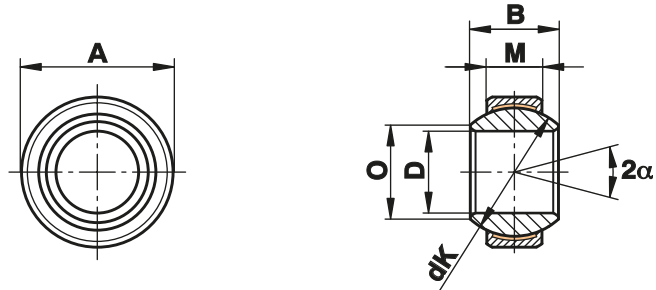

Size (D)	B	M	A	O	dK	Static load C ₀ kN	Static load C ₀ kN -2RS	Dynamic load C kN	Dynamic load C kN -2RS	Maximum Pivoting Angle α (°)	Weight g
4 ⁰ _{-0,008}	7	4	14 ⁰ _{-0,008}	7,1	10,0	9,1	-	3,6	-	20	5
5 ⁰ _{-0,008}	9	5	16 ⁰ _{-0,008}	9,3	13,0	14,0	-	5,8	-	21	8
6 ⁰ _{-0,008}	9	5	16 ⁰ _{-0,008}	9,3	13,0	14,0	-	5,8	-	21	9
8 ⁰ _{-0,008}	11	6	19 ⁰ _{-0,009}	11,6	16,0	21,0	-	8,6	-	21	14
10 ⁰ _{-0,008}	12	7	22 ⁰ _{-0,009}	13,4	18,0	28,0	-	11,0	-	18	21
12 ⁰ _{-0,008}	15	9	26 ⁰ _{-0,009}	16,0	22,0	45,0	-	18,0	-	18	33
15 ⁰ _{-0,008}	16	10	30 ⁰ _{-0,009}	19,2	25,0	56,0	75,0	22,0	32,0	16	49
17 ⁰ _{-0,008}	20	12	35 ⁰ _{-0,011}	21,0	29,0	78,0	104,0	31,0	45,0	19	83
20 ⁰ _{-0,010}	25	16	42 ⁰ _{-0,011}	25,2	35,5	127,0	204,0	51,0	85,0	17	153
25 ⁰ _{-0,010}	28	18	47 ⁰ _{-0,011}	29,5	40,7	166,0	263,0	65,0	110,0	17	203
30 ⁰ _{-0,010}	32	20	55 ⁰ _{-0,013}	34,4	47,0	211,0	338,0	84,0	140,0	17	304
35 ⁰ _{-0,012}	35	22	62 ⁰ _{-0,013}	39,7	53,0	262,0	419,0	104,0	175,0	16	408
40 ⁰ _{-0,012}	40	25	68 ⁰ _{-0,013}	44,7	60,0	337,0	540,0	135,0	225,0	17	542
45 ⁰ _{-0,012}	43	28	75 ⁰ _{-0,013}	50,0	66,0	415,0	665,0	166,0	275,0	15	713
50 ⁰ _{-0,012}	56	36	90 ⁰ _{-0,015}	57,1	80,0	-	1030,0	-	430,0	17	1420
60 ⁰ _{-0,015}	63	40	105 ⁰ _{-0,015}	67,0	92,0	-	1320,0	-	550,0	17	2090
70 ⁰ _{-0,015}	70	45	120 ⁰ _{-0,015}	78,2	105,0	-	1700,0	-	705,0	16	3010
80 ⁰ _{-0,015}	75	50	130 ⁰ _{-0,018}	87,1	115,0	-	2070,0	-	860,0	14	3610
90 ⁰ _{-0,020}	85	55	150 ⁰ _{-0,018}	98,3	130,0	-	2570,0	-	1070,0	15	5500
100 ⁰ _{-0,020}	85	55	160 ⁰ _{-0,025}	111,2	140,0	-	2770,0	-	1150,0	14	6040
110 ⁰ _{-0,020}	100	70	180 ⁰ _{-0,025}	124,8	160,0	-	4030,0	-	1680,0	12	9740
120 ⁰ _{-0,020}	115	70	210 ⁰ _{-0,030}	138,4	180,0	-	4530,0	-	1890,0	16	15100
140 ¹⁾ _{-0,025}	130	80	230 ⁰ _{-0,030}	151,9	200,0	-	5760,0	-	2400,0	16	18900
160 ¹⁾ _{-0,025}	135	80	260 ⁰ _{-0,035}	180,0	225,0	-	6480,0	-	2700,0	16	24800
180 ¹⁾ _{-0,025}	155	100	290 ⁰ _{-0,035}	196,1	250,0	-	9000,0	-	3750,0	14	35900
200 ¹⁾ _{-0,030}	165	100	320 ⁰ _{-0,040}	220,0	275,0	-	9900,0	-	4120,0	15	44900
220 ¹⁾ _{-0,030}	175	100	340 ⁰ _{-0,040}	243,6	300,0	-	10800,0	-	4500,0	16	50900
240 ¹⁾ _{-0,030}	190	110	370 ⁰ _{-0,040}	263,6	325,0	-	12870,0	-	5360,0	15	65300
260 ¹⁾ _{-0,035}	205	120	400 ⁰ _{-0,040}	283,6	350,0	-	15120,0	-	6300,0	15	82000
280 ¹⁾ _{-0,035}	210	120	430 ⁰ _{-0,045}	310,6	375,0	-	16200,0	-	6750,0	15	96600

Materials:

Insert: Bearing steel with PTFE liner bonded to the inner surface
 from size 15 available sealed (-2RS) on both sides
 from size 35 only available sealed (-2RS) on both sides

Ball: Bearing steel to 100Cr6, Aisi 52100, hardened, ground, polished, hard chrome plated on the running surface

1) from size 120 the hardened inserts are two pieced and secured with tension spring

Spherical Plain Bearing Series G - Stainless, maintenance free

Series

GE..FW-NIRO (-2RS)

Spherical Plain Bearing
Series G, Mating surface
NIRO/PTFE,
maintenance free

Increased Maximum
Pivoting Angle through a
wide ball

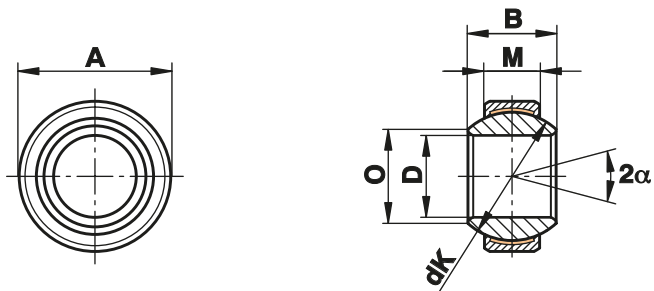

Size (D)	B	M	A	O	dK	Static load C ₀ kN	Static load C ₀ kN -2RS	Dynamic load C kN	Dynamic load C kN -2RS	Maximum Pivoting Angle α (°)	Weight g
4 ⁰ _{-0,008}	7	4	14 ⁰ _{-0,008}	7,1	10,0	9,0	-	4	-	20	5
5 ⁰ _{-0,008}	9	5	16 ⁰ _{-0,008}	9,3	13,0	15,6	-	7	-	21	8
6 ⁰ _{-0,008}	9	5	16 ⁰ _{-0,008}	9,3	13,0	15,6	-	7	-	21	9
8 ⁰ _{-0,008}	11	6	19 ⁰ _{-0,009}	11,6	16,0	23,4	-	10	-	21	14
10 ⁰ _{-0,008}	12	7	22 ⁰ _{-0,009}	13,4	18,0	32,0	-	14	-	18	21
12 ⁰ _{-0,008}	15	9	26 ⁰ _{-0,009}	16,0	22,0	50,0	-	30	-	18	33
15 ⁰ _{-0,008}	16	10	30 ⁰ _{-0,009}	19,2	25,0	65,0	-	39	-	16	49
17 ⁰ _{-0,008}	20	12	35 ⁰ _{-0,011}	21,0	29,0	90,5	-	54	-	19	83
20 ⁰ _{-0,010}	25	16	42 ⁰ _{-0,011}	25,2	35,5	159,0	137	96	78	17	153
25 ⁰ _{-0,010}	28	18	47 ⁰ _{-0,011}	29,5	40,7	197,0	155	118	89	17	203
30 ⁰ _{-0,010}	32	20	55 ⁰ _{-0,013}	34,4	47,0	298,0	217	153	124	17	304
35 ⁰ _{-0,012}	35	22	62 ⁰ _{-0,013}	39,7	53,0	370,6	276	190	158	16	408
40 ⁰ _{-0,012}	40	25	68 ⁰ _{-0,013}	44,7	60,0	481,0	353	247	202	17	542
45 ⁰ _{-0,012}	43	28	75 ⁰ _{-0,013}	50,0	66,0	598,0	457	308	261	15	713
50 ⁰ _{-0,012}	56	36	90 ⁰ _{-0,015}	57,1	80,0	935,0	722	481	413	17	1420
60 ⁰ _{-0,015}	63	40	105 ⁰ _{-0,015}	67,0	92,0	1204,0	976	619	558	17	2090
70 ⁰ _{-0,015}	70	45	120 ⁰ _{-0,015}	78,2	105,0	1540,0	1246	792	712	16	3010
80 ⁰ _{-0,015}	75	50	130 ⁰ _{-0,018}	87,1	115,0	1892,0	1525	1080	872	14	3610
90 ⁰ _{-0,020}	85	55	150 ⁰ _{-0,018}	98,3	130,0	2366,0	1997	1350	1141	15	5500
100 ⁰ _{-0,020}	85	55	160 ⁰ _{-0,025}	111,2	140,0	2548,0	2151	1460	1229	14	6040
110 ⁰ _{-0,020}	100	70	180 ⁰ _{-0,025}	124,8	160,0	3752,0	3186	2140	1821	12	9740

Materials:

Insert: Stainless steel to 1.4571, Aisi 316Ti, with PTFE liner bonded to the inner surface from size 80 with high performance PTFE compound from size 20 available sealed from both sides (-2RSF)

Ball: Stainless steel to 1.4125/1.4112, hardened, ground, polished

Sealing: H-Ecopur

Angular Contact Spherical Plain Bearings - Steel on Steel

Series GE..SX

Angular Contact Spherical Plain Bearings steel on steel. Treated with molybdenum disulphide mos2, greasable

For use at uni-directional, dynamic radial and additional axial loads

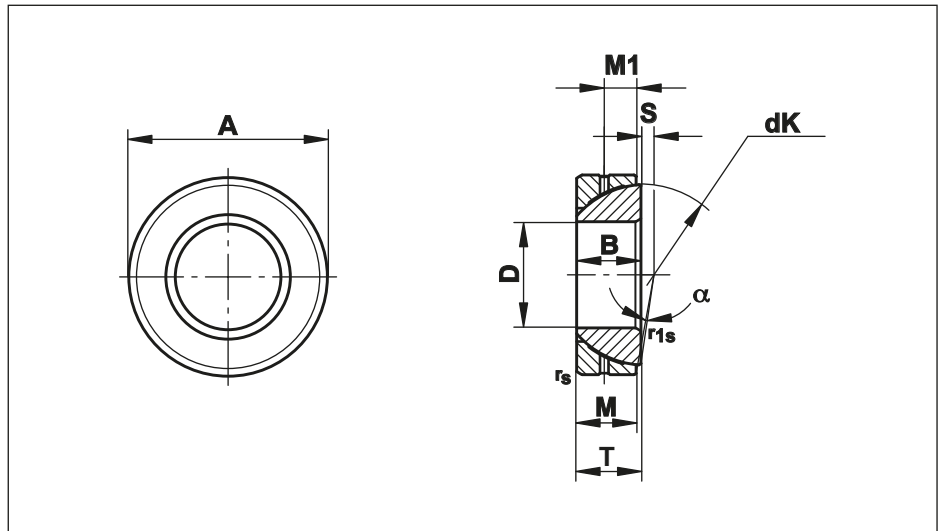

Size (D)	B	M	A	T	S	M1	rs, r1s min	dK	Radial Load kN		Maximum Pivoting Angle α (°)	Weight g
									Static Co	Dynamic C		
25 ⁰ _{-0,012}	15	14,0	47 ⁰ _{-0,014}	15 ^{+0,25} _{-0,40}	0,6	7,5	1,0	42,0	250	50	2,5	148
28 ⁰ _{-0,012}	15	15,0	52 ⁰ _{-0,016}	16 ^{+0,25} _{-0,40}	1,0	8,0	1,0	47,0	300	60	2,0	186
30 ⁰ _{-0,012}	17	15,0	55 ⁰ _{-0,016}	17 ^{+0,25} _{-0,40}	1,3	8,5	1,0	49,5	315	63	4,5	208
32 ⁰ _{-0,012}	17	16,0	58 ⁰ _{-0,016}	17 ^{+0,25} _{-0,40}	2,0	8,5	1,0	52,0	354	71	2,0	241
35 ⁰ _{-0,012}	18	16,0	62 ⁰ _{-0,016}	18 ^{+0,25} _{-0,40}	2,1	9,0	1,0	55,5	390	78	4,0	268
40 ⁰ _{-0,012}	19	17,0	68 ⁰ _{-0,016}	19 ^{+0,25} _{-0,40}	2,8	9,5	1,0	62,0	463	92	3,5	327
45 ⁰ _{-0,012}	20	18,0	75 ⁰ _{-0,016}	20 ^{+0,25} _{-0,40}	3,5	10,0	1,0	68,5	540	108	3,0	416
50 ⁰ _{-0,012}	20	19,0	80 ⁰ _{-0,016}	20 ^{+0,25} _{-0,40}	4,3	10,0	1,0	74,0	618	123	1,5	455
55 ⁰ _{-0,015}	23	20,0	90 ⁰ _{-0,018}	23 ^{+0,25} _{-0,50}	5,0	11,5	1,1	82,0	721	144	4,0	645
60 ⁰ _{-0,015}	23	21,0	95 ⁰ _{-0,018}	23 ^{+0,25} _{-0,50}	5,7	11,5	1,1	88,5	817	163	2,5	714
65 ⁰ _{-0,015}	23	22,0	100 ⁰ _{-0,018}	23 ^{+0,25} _{-0,50}	6,5	11,5	1,1	93,5	905	180	1,0	759
70 ⁰ _{-0,015}	25	23,0	110 ⁰ _{-0,018}	25 ^{+0,25} _{-0,50}	7,2	12,5	1,1	102,0	1030	206	2,0	1040
75 ⁰ _{-0,015}	25	24,0	115 ⁰ _{-0,018}	25 ^{+0,25} _{-0,50}	7,9	12,5	1,1	107,0	1129	220	1,0	1120
80 ⁰ _{-0,015}	29	25,5	125 ⁰ _{-0,020}	29 ^{+0,25} _{-0,50}	8,6	14,5	1,1	115,0	1290	258	3,5	1540
85 ⁰ _{-0,020}	29	26,5	130 ⁰ _{-0,020}	29 ^{+0,25} _{-0,60}	9,4	14,5	1,1	122,0	1422	284	2,0	1610
90 ⁰ _{-0,020}	32	28,0	140 ⁰ _{-0,020}	32 ^{+0,25} _{-0,60}	10,1	16,0	1,5	128,5	1580	316	3,5	2090
95 ⁰ _{-0,020}	32	29,5	145 ⁰ _{-0,020}	32 ^{+0,25} _{-0,60}	10,8	16,0	1,5	135,0	1750	350	2,0	2220
100 ⁰ _{-0,020}	32	31,0	150 ⁰ _{-0,020}	32 ^{+0,25} _{-0,60}	11,6	16,0	1,5	141,0	1923	384	0,5	2340
105 ¹⁾ _{-0,020}	35	32,5	160 ⁰ _{-0,025}	35 ^{+0,25} _{-0,60}	12,3	17,5	2,0	148,0	2116	423	2,0	2930
110 ¹⁾ _{-0,020}	38	34,0	170 ⁰ _{-0,025}	38 ^{+0,25} _{-0,60}	13,0	19,0	2,0	155,0	2318	463	3,0	3680
120 ¹⁾ _{-0,020}	38	37,0	180 ⁰ _{-0,025}	38 ^{+0,25} _{-0,60}	14,5	19,0	2,0	168,0	2735	547	0,5	3970
130 ¹⁾ _{-0,025}	45	43,0	200 ⁰ _{-0,030}	45 ^{+0,35} _{-0,70}	18,0	19,0	2,5	188,0	3550	710	1,0	5920
140 ¹⁾ _{-0,025}	45	43,0	210 ⁰ _{-0,030}	45 ^{+0,35} _{-0,70}	19,0	19,0	2,5	198,0	3740	740	1,0	6330
150 ¹⁾ _{-0,025}	48	46,0	225 ⁰ _{-0,030}	48 ^{+0,35} _{-0,70}	20,0	20,5	3,0	211,0	4270	850	1,0	8010
160 ¹⁾ _{-0,025}	51	49,0	240 ⁰ _{-0,030}	51 ^{+0,35} _{-0,70}	20,0	22,0	3,0	225,0	4850	970	1,0	9790
170 ¹⁾ _{-0,025}	57	55,0	260 ⁰ _{-0,035}	57 ^{+0,35} _{-0,70}	21,0	27,0	3,0	246,0	5950	1190	1,0	12300
180 ¹⁾ _{-0,025}	64	61,0	280 ⁰ _{-0,035}	64 ^{+0,35} _{-0,70}	21,0	28,0	3,0	260,0	6970	1395	1,0	17400
190 ¹⁾ _{-0,030}	64	62,0	290 ⁰ _{-0,035}	64 ^{+0,35} _{-0,80}	26,0	30,0	3,0	275,0	7500	1500	0,5	18200
200 ¹⁾ _{-0,030}	70	66,0	310 ⁰ _{-0,035}	70 ^{+0,35} _{-0,80}	26,0	30,0	3,0	290,0	8420	1680	1,5	23800

Materials:

Housing disk: Bearing steel to 100Cr6, Aisi 52100, hardened, ground, phosphated treated with molybdenum disulphide

Inner disk: Bearing steel to 100Cr6, Aisi 52100, hardened, ground, phosphated treated with molybdenum disulphide

1) Price and availability on request

FLURO®-Gelenklager GmbH

Angular Contact Spherical Plain Bearings - Maintenance Free

Series GE..SW

Angular Contact Spherical Plain Bearings. Mating surface hard chromium/PTFE, maintenance free

For use at uni-directional, dynamic radial and additional axial loads

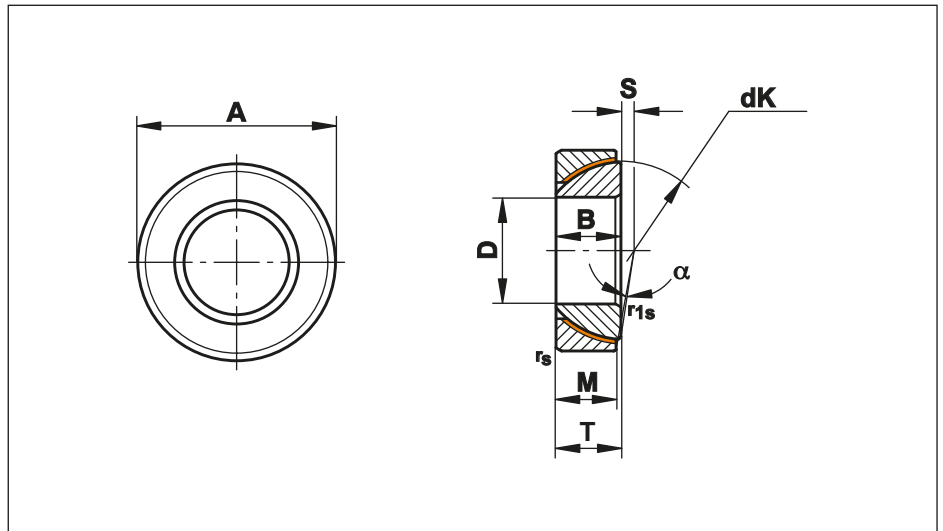

Size (D)	B	M	A	T	S	rs, r1s min	dK	Radial Load kN		Maximum Pivoting Angle α (°)	Weight g
								Static Co	Dynamic C		
25 ⁰ _{-0,012}	15	14,0	47 ⁰ _{-0,014}	15 ^{+0,25} _{-0,40}	0,6	1,0	42,0	225	89	2,5	148
28 ⁰ _{-0,012}	15	15,0	52 ⁰ _{-0,016}	16 ^{+0,25} _{-0,40}	1,0	1,0	47,0	270	100	2,0	186
30 ⁰ _{-0,012}	17	15,0	55 ⁰ _{-0,016}	17 ^{+0,25} _{-0,40}	1,3	1,0	49,5	285	110	4,5	208
32 ⁰ _{-0,012}	17	16,0	58 ⁰ _{-0,016}	17 ^{+0,25} _{-0,40}	2,0	1,0	52,0	320	125	2,0	241
35 ⁰ _{-0,012}	18	16,0	62 ⁰ _{-0,016}	18 ^{+0,25} _{-0,40}	2,1	1,0	55,5	340	135	4,0	268
40 ⁰ _{-0,012}	19	17,0	68 ⁰ _{-0,016}	19 ^{+0,25} _{-0,40}	2,8	1,0	62,0	400	160	3,5	327
45 ⁰ _{-0,012}	20	18,0	75 ⁰ _{-0,016}	20 ^{+0,25} _{-0,40}	3,5	1,0	68,5	470	190	3,0	416
50 ⁰ _{-0,012}	20	19,0	80 ⁰ _{-0,016}	20 ^{+0,25} _{-0,40}	4,3	1,0	74,0	540	215	1,5	455
55 ⁰ _{-0,015}	23	20,0	90 ⁰ _{-0,018}	23 ^{+0,25} _{-0,50}	5,0	1,1	82,0	630	250	4,0	645
60 ⁰ _{-0,015}	23	21,0	95 ⁰ _{-0,018}	23 ^{+0,25} _{-0,50}	5,7	1,1	88,5	710	285	2,5	714
65 ⁰ _{-0,015}	23	22,0	100 ⁰ _{-0,018}	23 ^{+0,25} _{-0,50}	6,5	1,1	93,5	790	315	1,0	759
70 ⁰ _{-0,015}	25	23,0	110 ⁰ _{-0,018}	25 ^{+0,25} _{-0,50}	7,2	1,1	102,0	900	360	2,0	1040
75 ⁰ _{-0,015}	25	24,0	115 ⁰ _{-0,018}	25 ^{+0,25} _{-0,50}	7,9	1,1	107,0	980	395	1,0	1120
80 ⁰ _{-0,015}	29	25,5	125 ⁰ _{-0,020}	29 ^{+0,25} _{-0,50}	8,6	1,1	115,0	1120	450	3,5	1540
85 ⁰ _{-0,020}	29	26,5	130 ⁰ _{-0,020}	29 ^{+0,25} _{-0,60}	9,4	1,1	122,0	1240	495	2,0	1610
90 ⁰ _{-0,020}	32	28,0	140 ⁰ _{-0,020}	32 ^{+0,25} _{-0,60}	10,1	1,5	128,5	1380	550	3,5	2090
95 ⁰ _{-0,020}	32	29,5	145 ⁰ _{-0,020}	32 ^{+0,25} _{-0,60}	10,8	1,5	135,0	1530	610	2,0	2220
100 ⁰ _{-0,020}	32	31,0	150 ⁰ _{-0,020}	32 ^{+0,25} _{-0,60}	11,6	1,5	141,0	1680	670	0,5	2340
105 ¹⁾ _{-0,020}	35	32,5	160 ⁰ _{-0,020}	35 ^{+0,25} _{-0,60}	12,3	2,0	148,0	1850	740	2,0	2930
110 ¹⁾ _{-0,020}	38	34,0	170 ⁰ _{-0,020}	38 ^{+0,25} _{-0,60}	13,0	2,0	155,0	2020	810	3,0	3680
120 ¹⁾ _{-0,020}	38	37,0	180 ⁰ _{-0,025}	38 ^{+0,25} _{-0,60}	14,5	2,0	168,0	2390	955	0,5	3970
130 ¹⁾ _{-0,020}	45	43,0	200 ⁰ _{-0,025}	45 ^{+0,35} _{-0,70}	18,0	2,5	188,0	3110	1240	1,0	5920
140 ¹⁾ _{-0,020}	45	43,0	210 ⁰ _{-0,025}	45 ^{+0,35} _{-0,70}	19,0	2,5	198,0	3270	1310	1,0	6330
150 ¹⁾ _{-0,025}	48	46,0	225 ⁰ _{-0,030}	48 ^{+0,35} _{-0,70}	20,0	3,0	211,0	3730	1490	1,0	8010
160 ¹⁾ _{-0,025}	51	49,0	240 ⁰ _{-0,030}	51 ^{+0,35} _{-0,70}	20,0	3,0	225,0	4240	1690	1,0	9790
170 ¹⁾ _{-0,025}	57	55,0	260 ⁰ _{-0,035}	57 ^{+0,35} _{-0,70}	21,0	3,0	246,0	5200	2080	1,0	12300
180 ¹⁾ _{-0,025}	64	61,0	280 ⁰ _{-0,035}	64 ^{+0,35} _{-0,70}	21,0	3,0	260,0	6100	2440	1,0	17400
190 ¹⁾ _{-0,030}	64	62,0	290 ⁰ _{-0,035}	64 ^{+0,35} _{-0,80}	26,0	3,0	275,0	6560	2620	0,5	18200
200 ¹⁾ _{-0,030}	70	66,0	310 ⁰ _{-0,035}	70 ^{+0,35} _{-0,80}	26,0	3,0	290,0	7360	2940	1,5	23800

Materials:

Housing disk: Bearing steel to 100Cr6, Aisi 52100, hardened with PTFE liner bonded to the inner surface

Inner disk: Bearing steel to 100Cr6, Aisi 52100, hardened, ground, polished, hard chrome plated

On request: Stainless steel version

1) Price and availability on request

Spherical Plain Thrust Bearings - Steel on Steel

Series GE..AX

Spherical Plain Thrust Bearings steel on steel.
Treated with molybdenum disulphide mos2, regreasable

For use at axial loads

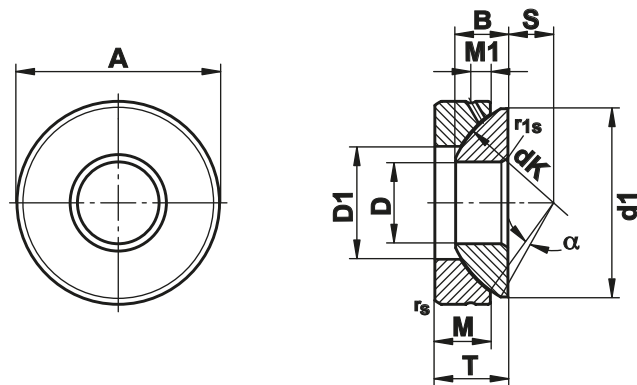

Size (D)	B	M	A	T	S	M1	r _s , r _{1s} min	d ₁ max	D ₁ min	dK	Axiale load kN		Maximum Pivoting Angle α (°)	Weight g
											Static C ₀	Dynamic C		
10 ⁰ _{-0,008}	7,5	7,0	30 ⁰ _{-0,009}	9,5 ^{+0,25} _{-0,40}	7,0	3,0	0,6	27,5	15,5	32	136	27	5	36
12 ⁰ _{-0,008}	9,5	9,3	35 ⁰ _{-0,011}	13,0 ^{+0,25} _{-0,40}	8,0	4,0	0,6	32,0	18,0	38	188	37	5	72
15 ⁰ _{-0,008}	11,0	10,8	42 ⁰ _{-0,011}	15,0 ^{+0,25} _{-0,40}	10,0	5,0	0,6	39,0	22,5	46	267	53	6	108
17 ⁰ _{-0,008}	11,8	11,2	47 ⁰ _{-0,011}	16,0 ^{+0,25} _{-0,40}	11,0	5,0	0,6	43,5	27,0	52	311	61	4	137
20 ⁰ _{-0,010}	14,5	13,8	55 ⁰ _{-0,013}	20,0 ^{+0,25} _{-0,40}	12,5	6,0	1,0	50,0	31,0	60	425	84	5	246
25 ⁰ _{-0,010}	16,5	16,7	62 ⁰ _{-0,013}	22,5 ^{+0,25} _{-0,40}	14,0	6,0	1,0	58,5	34,5	68	672	134	5	415
30 ⁰ _{-0,010}	19,0	19,0	75 ⁰ _{-0,013}	26,0 ^{+0,25} _{-0,40}	17,5	8,0	1,0	70,0	42,0	82	909	182	5	614
35 ⁰ _{-0,012}	22,0	20,7	90 ⁰ _{-0,015}	28,0 ^{+0,25} _{-0,40}	22,0	8,0	1,0	84,0	50,5	98	1330	266	5	973
40 ⁰ _{-0,012}	27,0	21,5	105 ⁰ _{-0,015}	32,0 ^{+0,25} _{-0,40}	24,5	9,0	1,0	97,0	59,0	114	1810	357	6	1590
45 ⁰ _{-0,012}	31,0	25,5	120 ⁰ _{-0,015}	36,5 ^{+0,25} _{-0,40}	27,5	11,0	1,0	110,0	67,0	128	2470	486	6	2240
50 ⁰ _{-0,012}	33,0	30,5	130 ⁰ _{-0,018}	42,5 ^{+0,25} _{-0,40}	30,0	10,0	1,0	120,0	70,0	139	2810	554	6	3140
60 ⁰ _{-0,015}	37,0	34,0	150 ⁰ _{-0,018}	45,0 ^{+0,25} _{-0,50}	35,0	12,5	1,0	140,0	84,0	160	3820	748	6	4630
70 ⁰ _{-0,015}	42,0	36,5	160 ⁰ _{-0,025}	50,0 ^{+0,25} _{-0,50}	35,0	13,5	1,0	153,0	94,5	176	4610	902	3	5370
80 ⁰ _{-0,015}	43,5	38,0	180 ⁰ _{-0,025}	50,0 ^{+0,25} _{-0,50}	42,5	14,5	1,0	172,0	107,5	197	5700	1110	4	6910
100 ⁰ _{-0,020}	51,0	46,0	210 ⁰ _{-0,030}	59,0 ^{+0,25} _{-0,60}	45,0	15,0	1,1	198,0	127,0	222	6470	1300	4	11000
120 ¹⁾ _{-0,020}	53,5	50,0	230 ⁰ _{-0,030}	64,0 ^{+0,25} _{-0,60}	52,5	16,5	1,1	220,0	145,0	250	7580	1530	3	14000
140 ¹⁾ _{-0,025}	61,0	54,0	260 ⁰ _{-0,035}	72,0 ^{+0,35} _{-0,70}	52,5	23,0	1,5	243,0	177,0	274	9040	1820	3	19100
160 ¹⁾ _{-0,025}	66,0	58,0	290 ⁰ _{-0,035}	77,0 ^{+0,35} _{-0,70}	65,0	23,0	1,5	271,0	200,0	313	10440	2100	2	25000
180 ¹⁾ _{-0,025}	74,0	62,0	320 ⁰ _{-0,040}	86,0 ^{+0,35} _{-0,70}	67,5	26,0	1,5	299,0	225,0	340	12070	2430	4	32800
200 ¹⁾ _{-0,030}	80,0	66,0	340 ⁰ _{-0,045}	87,0 ^{+0,35} _{-0,80}	70,0	27,0	1,5	320,0	247,0	365	15280	3070	1	35400

Materials:

Housing disk: Bearing steel to 100Cr6, Aisi 52100, hardened, ground, phosphated treated with molybdenum disulphide

Inner disk: Bearing steel to 100Cr6, Aisi 52100, hardened, ground, phosphated treated with molybdenum disulphide

1) Price and availability on request

Spherical Plain Thrust Bearings - Maintenance Free

Series GE..AW

Spherical Plain Thrust Bearings.
Mating surface hard chromium/PTFE, maintenance free

For use with axial loads

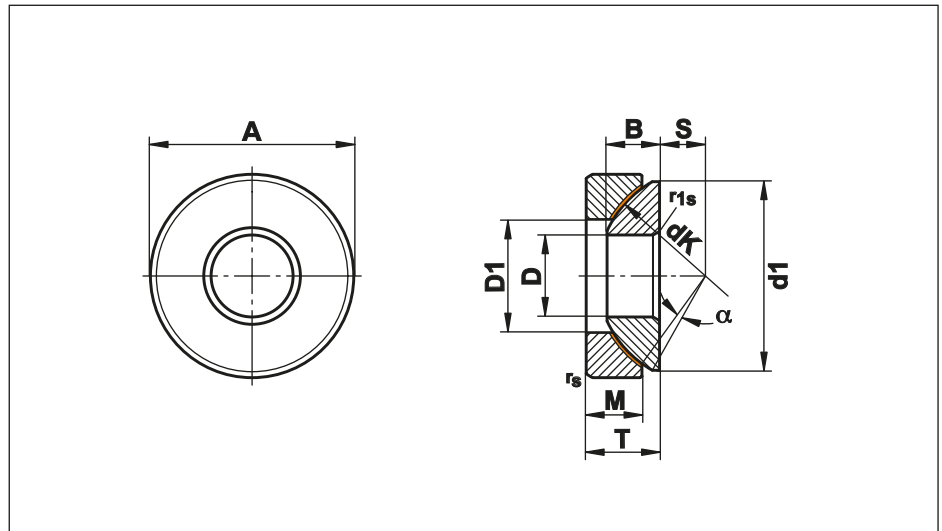

Size (D)	B	M	A	T	S	r _s , r _{1s} min	d ₁ max	D ₁ min	dK	Axiale load kN		Maximum Pivoting Angle α (°)	Weight g
										Static C ₀	Dynamic C		
10	7,5	7,0	30	9,5	7,0	0,6	27,5	15,5	32	120	45	5,0	36
12	9,5	9,3	35	13,0	8,0	0,6	32,0	18,0	38	165	65	5,0	72
15	11,0	10,8	42	15,0	10,0	0,6	39,0	22,5	46	235	95	6,0	108
17	11,8	11,2	47	16,0	11,0	0,6	43,5	27,0	52	275	110	4,0	137
20	14,5	13,8	55	20,0	12,5	1,0	50,0	31,0	60	380	150	5,0	246
25	16,5	16,7	62	22,5	14,0	1,0	58,5	34,5	68	600	245	5,0	415
30	19,0	19,0	75	26,0	17,5	1,0	70,0	42,0	82	820	335	5,0	614
35	22,0	20,7	90	28,0	22,0	1,0	84,0	50,5	98	1200	490	5,0	973
40	27,0	21,5	105	32,0	24,5	1,0	97,0	59,0	114	1640	675	6,0	1590
45	31,0	25,5	120	36,5	27,5	1,0	110,0	67,0	128	2240	915	6,0	2240
50	33,0	30,5	130	42,5	30,0	1,0	120,0	70,0	139	2550	1040	6,0	3140
60	37,0	34,0	150	45,0	35,0	1,0	140,0	84,0	160	3470	1360	6,0	4630
70	42,0	36,5	160	50,0	35,0	1,0	153,0	94,5	176	4180	1640	3,0	5370
80	43,5	38,0	180	50,0	42,5	1,0	172,0	107,5	197	5180	2030	4,0	6910
100	51,0	46,0	210	59,0	45,0	1,1	198,0	127,0	222	5940	2230	4,0	11000
120 ¹⁾	53,5	50,0	230	64,0	52,5	1,1	220,0	145,0	250	6960	2610	3,0	14000
140 ¹⁾	61,0	54,0	260	72,0	52,5	1,5	243,0	177,0	274	8300	3120	3,0	19100
160 ¹⁾	66,0	58,0	290	77,0	65,0	1,5	271,0	200,0	313	9560	3380	2,0	25000
180 ¹⁾	74,0	62,0	320	86,0	67,5	1,5	299,0	225,0	340	11050	3910	4,0	32800
200 ¹⁾	80,0	66,0	340	87,0	70,0	1,5	320,0	247,0	365	13990	4950	1,0	35400
220 ¹⁾	82,0	67,0	370	97,0	75,0	1,5	350,0	265,5	388	13110	4640	7,0	44700
240 ¹⁾	87,0	73,0	400	103,0	77,5	1,5	382,0	294,0	420	15560	5500	6,0	56900
260 ¹⁾	95,0	80,0	430	115,0	82,5	1,5	409,0	317,0	449	17510	6190	7,0	71300
280 ¹⁾	100,0	85,0	460	110,0	80,0	3,0	445,0	337,0	480	23400	8280	4,0	84700
300 ¹⁾	100,0	90,0	480	110,0	80,0	3,0	460,0	356,0	490	25480	9010	3,5	88900
320 ¹⁾	105,0	91,0	520	116,0	95,0	4,0	500,0	380,0	540	33260	11360	4,0	111000
340 ¹⁾	105,0	91,0	540	116,0	95,0	4,0	510,0	380,0	550	33880	11570	4,0	117000
360 ¹⁾	115,0	95,0	560	125,0	95,0	4,0	535,0	400,0	575	37630	12850	4,0	132000

Materials:

Housing disk: Bearing steel to 100Cr6, Aisi 52100, hardened with PTFE liner bonded to the inner surface

Inner disk: Bearing steel to 100Cr6, Aisi 52100, hardened, ground, polished, hard chrome plated

On request: Stainless steel version

¹⁾ Price and availability on request

Hydraulic Rod Ends to DIN 24555 / ISO 8133

Series FPR..S

Rod Ends, fastened by hexagon socket head cap screw to DIN 912-8.8.
Spherical Plain Bearings, regreasable, fixed through caulking on both sides

For use in standard Hydraulic Cylinders 160 bar to ISO 6020/2

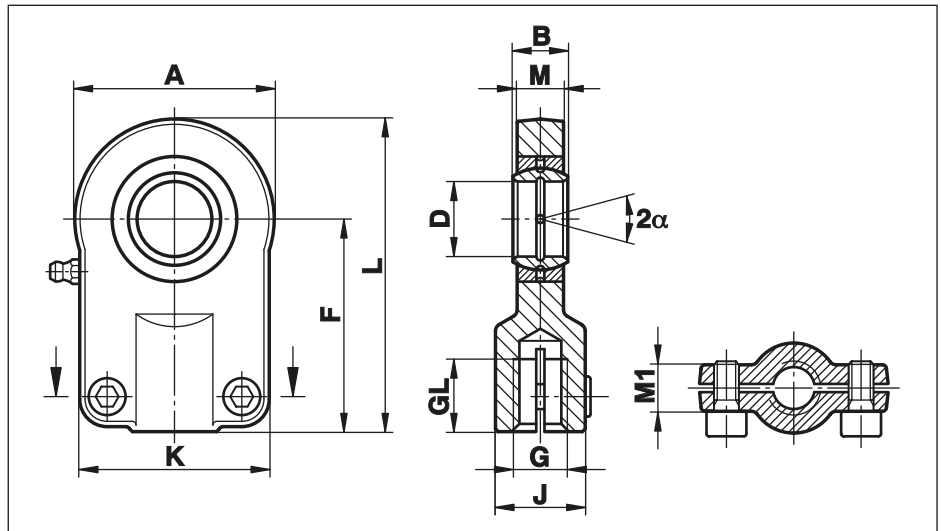

Size (D)	B	M	M1	A	F	L	K	J	G	GL	Torque Nm	Static load C ₀ kN	Dynamic load C kN	Maximum Pivoting Angle α (°)	Weight g
12	10	8	13	35	42	58,0	40	17	M 10x1,25	15	10	17,0	10,8	11	120
16	14	11	13	45	48	69,0	45	21	M 12x1,25	17	10	28,5	21,1	10	220
20	16	13	17	55	58	83,0	55	25	M 14x1,5	19	25	42,5	30,0	9	430
25	20	17	17	65	68	99,0	62	30	M 16x1,5	23	25	67,0	48,0	7	670
30	22	19	19	80	85	123,0	77	36	M 20x1,5	29	49	108,0	62,0	6	1250
40	28	23	23	100	105	153,0	90	45	M 27x2	37	49	156,0	100,0	7	2160
50	35	30	30	120	130	188,0	105	55	M 33x2	46	86	245,0	156,0	6	3900
60	44	38	38	160	150	230,0	134	68	M 42x2	57	210	380,0	245,0	6	7150
80	55	47	47	205	185	282,5	156	90	M 48x2	64	410	585,0	400,0	6	15000
100	70	55	55	240	240	357,5	190	110	M 64x3	86	710	865,0	610,0	7	27300

Materials:

Housing: up to size 50 forged from heat-treated steel to C45, Aisi 1045
from size 60 made from nodular cast iron GS 400

Bearing: Steel on steel bearing GE..E, requiring lubrication (see page 78)

Greasing: Size 12 is not regreasable
from size 16 - 20 fitted with grease hole in housing
from size 25 fitted with hydraulic grease nipples to DIN 71412

On request: with left hand thread (FPL..S)

Hydraulic Rod Ends to DIN 24338 / ISO 6982

Series FPR..CE

Rod Ends Cetop, recommendation RP 58H for standard Hydraulic Cylinders, fastened by hexagon socket head cap screws to DIN 912-8.8. Spherical Plain Bearings, regreasable, fixed with snap rings

Mounting dimensions to DIN 24333-24336 and ISO 6020/1, ISO 6022

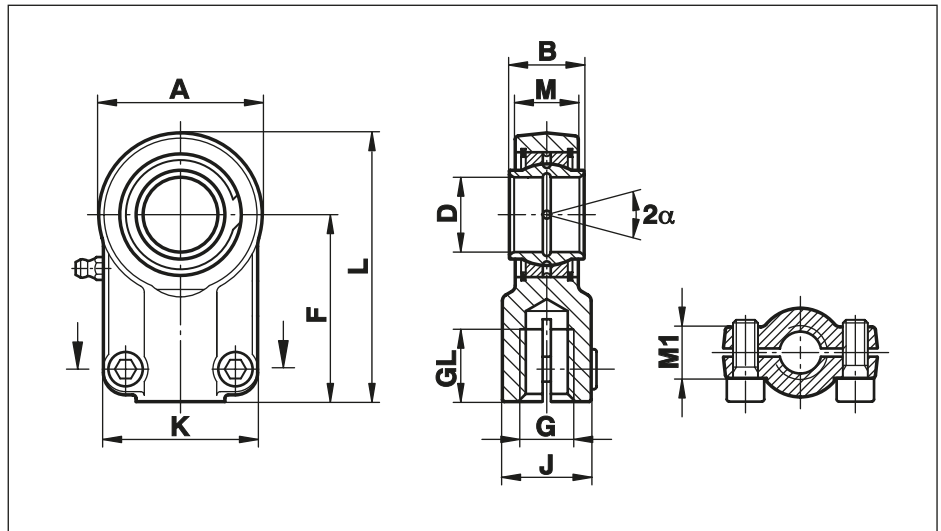

Size (D)	B	M	M1	A	F	L	K	J	G	GL	Torque Nm	Static load C ₀ kN	Dynamic load C kN	Maximum Pivoting Angle α (°)	Weight g
12	12	11,0	15,0	32,0	38	54,0	32	16	M 12x1,25	17	6	24,5	10,8	4	110
16	16	13,0	15,0	40,0	44	64,0	40	21	M 14x1,5	19	10	36,5	17,6	4	200
20	20	17,0	19,0	47,0	52	77,0	47	25	M 16x1,5	23	25	48,0	30,0	4	350
25	25	22,0	19,0	58,0	65	96,0	54	30	M 20x1,5	29	25	78,0	48,0	4	620
32	32	28,0	22,0	71,0	80	118,0	66	38	M 27x2	37	49	114,0	67,0	4	1150
40	40	33,0	26,0	90,0	97	146,0	80	47	M 33x2	46	49	204,0	100,0	4	2180
50	50	41,0	32,0	109,0	120	179,0	96	58	M 42x2	57	86	310,0	156,0	4	3960
63	63	53,0	38,0	136,0	140	213,0	114	70	M 48x2	64	210	430,0	255,0	4	6800
70	70	57,0	42,0	155,0	160	245,0	135	80	M 56x2	76	210	540,0	315,0	4	9600
80	80	67,0	48,0	170,0	180	270,0	148	90	M 64x3	86	410	695,0	400,0	4	13000
90	90	72,0	52,0	185,0	195	296,0	160	100	M 72x3	91	410	750,0	490,0	4	19100
100	100	85,0	62,0	211,0	210	322,0	178	110	M 80x3	96	710	1060,0	610,0	4	25000
110	110	88,0	62,0	235,0	235	364,0	190	125	M 90x3	106	710	1200,0	655,0	4	32000
125	125	103,0	72,0	265,0	260	406,5	200	135	M 100x3	113	710	1430,0	950,0	4	46000
160	160	130,0	82,0	326,0	310	488,0	250	165	M 125x4	126	710	2200,0	1370,0	4	82500
200	200	162,0	102,0	418,0	390	620,0	320	215	M 160x4	161	1500	3650,0	2120,0	4	168000

Materials:

Housing: up to size 63 forged from heat-treated steel to C45, Aisi 1045
from size 70 made from nodular cast iron GS 400

Bearing: Steel on steel bearing GE..LO (see page 82)

Greasing: size 12 is not regreasable
from size 16 fitted with hydraulic grease nipples to DIN 71412

On request: with left hand thread (FPL..CE)

Hydraulic Rod Ends

Series FPR..N

Rod Ends with short thread, particular suited for Hydraulic Cylinders. Spherical Plain Bearings, regreasable, fixed with snap rings

For use with shortest relay distances and maximum stroke utilization

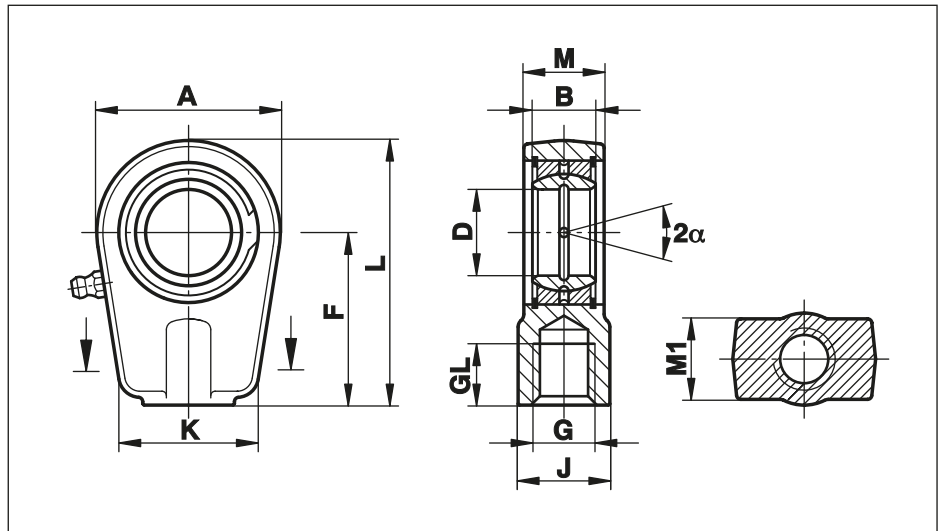

Size (D)	B	M	M1	A	F	L	K	J	G	GL	Static load C ₀ kN	Dynamic load C kN	Maximum Pivoting Angle α (°)	Weight g
20	16	19	17	56	50	80,0	46	25	M 16x1,5	17	81,1	30	9	450
25	20	23	21	56	50	80,0	46	25	M 16x1,5	17	72,0	48	7	490
30	22	28	26	64	60	94,0	50	32	M 22x1,5	23	106,0	62	6	760
35	25	30	28	78	70	112,0	66	40	M 28x1,5	29	153,0	80	6	1260
40	28	35	33	94	85	135,0	76	49	M 35x1,5	36	250,0	100	7	2150
50	35	40	37	116	105	168,0	90	61	M 45x1,5	46	365,0	156	6	3800
60	44	50	46	130	130	200,0	120	75	M 58x1,5	59	400,0	245	6	6200
70	49	55	51	154	150	232,0	130	86	M 65x1,5	66	540,0	315	6	9830
80	55	60	55	176	170	265,0	160	105	M 80x2	81	670,0	400	6	13970
90	60	65	60	206	210	322,0	180	124	M 100x2	101	980,0	490	5	23500
100	70	70	65	231	235	360,0	200	138	M 110x2	111	1120,0	610	7	32000
110	70	80	74	266	265	407,0	220	152	M 120x3	125	1700,0	655	6	41000
120	85	90	84	340	310	490,0	257	172	M 130x3	135	2900,0	950	6	72000

Materials:

Housing: up to size 80 forged from heat-treated steel to C45, Aisi 1045
from size 90 made from nodular cast iron GS 400

Bearing: Steel on steel bearing GE...E, requiring maintenance (see page 78)

Greasing: fitted with hydraulic grease nipples to DIN 71412

On request: with left hand thread (FPL..N)

Hydraulic Rod Ends

Series FPR..U

Rod Ends identical with FPR..N, in addition fastened by hexagon socket head cap screws to DIN 912-8.8. Spherical Plain Bearings, regreasable, fixed with snap rings

For use with shortest relay distances and maximum stroke utilization

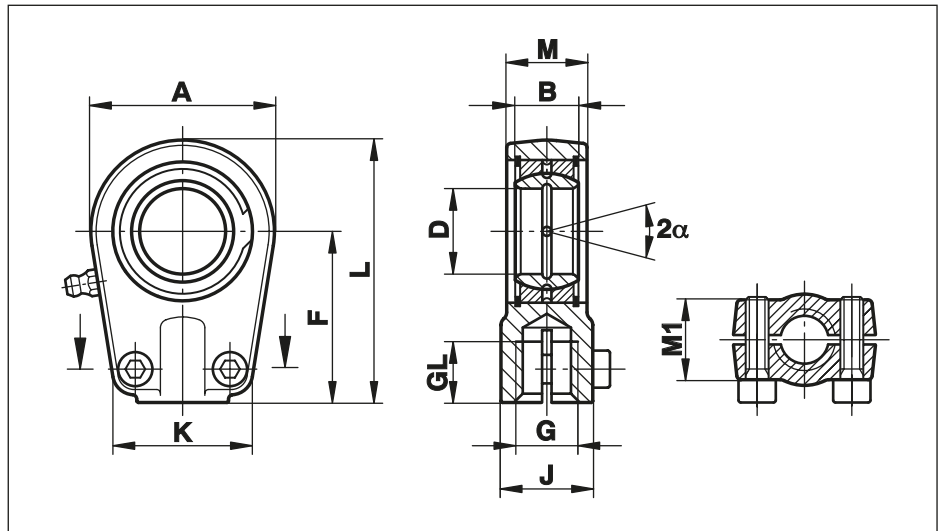

Size (D)	B	M	M1	A	F	L	K	J	G	GL	Torque Nm	Static load C ₀ kN	Dynamic load C kN	Maximum Pivoting Angle α (°)	Weight g
20	16	19	17	56	50	80,0	46	25	M 16x1,5	17	25	81,1	30	9	440
25	20	23	21	56	50	80,0	46	25	M 16x1,5	17	25	72,0	48	7	470
30	22	28	26	64	60	94,0	50	32	M 22x1,5	23	25	106,0	62	6	770
35	25	30	28	78	70	112,0	66	40	M 28x1,5	29	49	153,0	80	6	1240
40	28	35	33	94	85	135,0	76	49	M 35x1,5	36	49	250,0	100	7	2120
50	35	40	37	116	105	168,0	90	61	M 45x1,5	46	86	365,0	156	6	3740
60	44	50	46	130	130	200,0	120	75	M 58x1,5	59	210	400,0	245	6	6490
70	49	55	51	154	150	232,0	130	86	M 65x1,5	66	210	540,0	315	6	9880
80	55	60	55	176	170	265,0	160	105	M 80x2	81	410	670,0	400	6	14200
90	60	65	60	206	210	322,0	180	124	M 100x2	101	410	980,0	490	5	20000
100	70	70	65	231	235	360,0	200	138	M 110x2	111	710	1120,0	610	7	27500
110	70	80	74	266	265	407,5	220	152	M 120x3	125	710	1700,0	655	6	45600
120	85	90	84	340	310	490,0	257	172	M 130x3	135	710	2900,0	950	6	72000

Materials:

Housing: up to size 80 forged from heat-treated steel to C45, Aisi 1045
from size 90 made from nodular cast iron GS 400

Bearing: Steel on steel bearing GE...E, requiring maintenance (see page 78)
On request also available with Spherical Plain Bearing GE...LO (see page 82)

Greasing: fitted with hydraulic grease nipples to DIN 71412

On request: with left hand thread (FPL..U)

Hydraulic Rod Ends

Series FMA..D

Rod Ends fastened by hexagon socket head cap screws to DIN 912-8.8.
Spherical Plain Bearings, regreasable, fixed with snap rings

For use with double action Hydraulic Cylinders

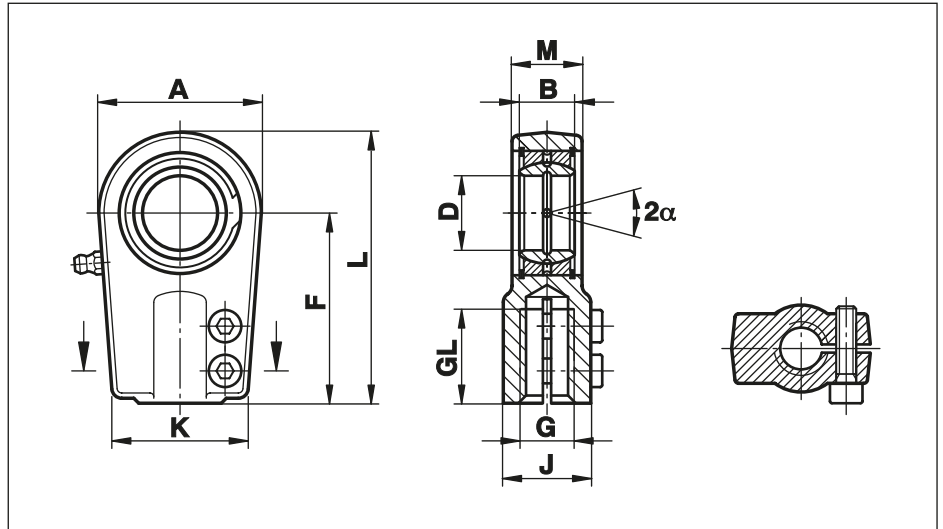

Size (D)	B	M	A	F	L	K	J	G	GL	Torque Nm	Static load C ₀ kN	Dynamic load C kN	Maximum Pivoting Angle α (°)	Weight g
25	20	23	56	65	95	48	28	M 18x2	30	20	76	48	8	650
30	22	28	64	75	109	56	34	M 24x2	35	20	112	62	7	1000
35	25	30	78	90	132	70	44	M 30x2	45	40	180	80	7	1300
40	28	35	94	105	155	78	55	M 39x3	55	80	295	100	7	2400
50	35	40	116	135	198	88	70	M 50x3	75	80	445	156	7	4100
60	44	50	130	170	240	118	87	M 64x3	95	160	530	245	7	6500
70	49	55	154	195	278	138	105	M 80x3	110	160	720	315	6	9500
80	55	60	176	210	305	168	125	M 90x3	120	300	890	400	6	16000
90	60	65	206	250	363	180	150	M 100x3	140	300	1300	490	5	28000
100	70	70	230	275	400	188	170	M 110x4	150	300	1490	610	7	34000
110	70	80	264	300	442	210	180	M 120x4	160	500	2050	650	6	44000
120	85	90	340	360	540	240	210	M 150x4	190	500	2970	950	6	75000
140	90	110	380	420	620	256	230	M 160x4	210	1100	3350	1080	7	160000
160	105	110	480	460	710	290	260	M 180x4	230	1100	4300	1370	8	185000

Materials:

Housing: Nodular cast iron GS400

Bearing: Steel on steel bearing GE..E, requiring lubrication (see page 78)

Greasing: size 25 without lubrication fitting, but fitted with grease hole in housing from size 30 fitted with hydraulic grease nipples to DIN 71412

On request: with left hand thread (FMAL..D)

Hydraulic Rod Ends - Weld-On Base

Series FS..C

Rod Ends series E to DIN ISO 12240-4, type S with circular surface for weld-on. Spherical Plain Bearings, regreasable, fixed through caulking on both sides

For Weld-on to piston Rod Ends

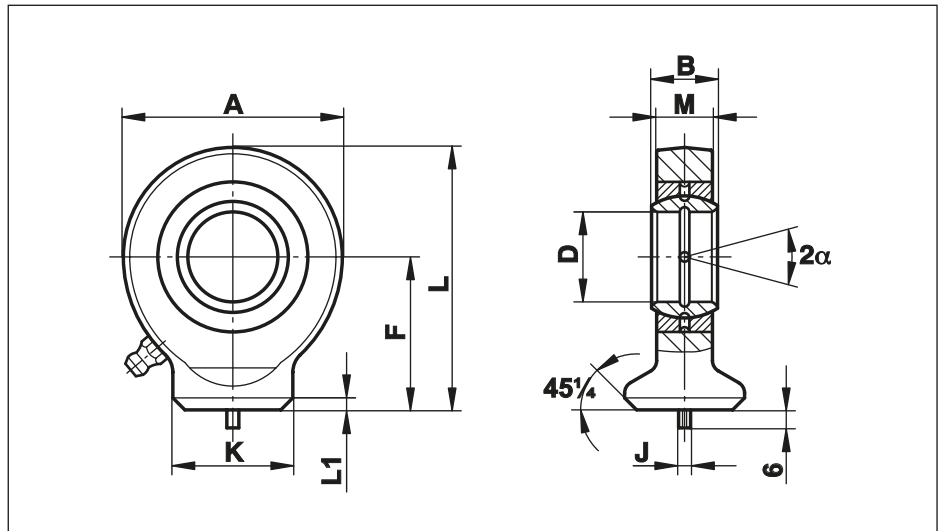

Size (D)	B	M	A	F	L	L1	K	J	Static load C ₀ kN	Dynamic load C kN	Maximum Pivoting Angle α (°)	Weight g
10	9	7	29	24	38,5	1,5	15,0	3	15,6	8,15	12	40
12	10	8	34	27	44,0	1,5	17,5	3	21,6	10,80	11	60
15	12	10	40	31	51,0	2,0	21,0	4	32,0	17,00	8	120
17	14	11	46	35	58,0	2,0	24,0	4	40,0	21,20	10	180
20	16	13	53	38	64,5	2,0	27,5	4	54,0	30,00	9	260
25	20	17	64	45	77,0	3,0	33,5	4	72,0	48,00	7	450
30	22	19	73	51	87,5	3,0	40,0	4	95,0	62,00	6	670
35	25	21	82	61	102,0	3,0	47,0	4	125,0	80,00	6	1020
40	28	23	92	69	115,0	4,0	52,0	4	156,0	100,00	7	1400
45	32	27	102	77	128,0	4,0	58,0	6	208,0	127,00	7	1930
50	35	30	112	88	144,0	4,0	62,0	6	250,0	156,00	6	2690
60	44	38	135	100	167,5	4,0	70,0	6	390,0	245,00	6	4600
70	49	42	160	115	195,0	5,0	80,0	6	510,0	315,00	6	7000
80	55	47	180	141	231,0	5,0	95,0	6	620,0	400,00	6	11000

Materials:

Housing: St 52-3, forged

Bearing: Steel on steel bearing GE...E, requiring maintenance (see page 78)
On request: available with maintenance free Spherical Plain Bearing GE..EC (see page 70) or in sizes 12, 20, 25, 40, 50, 70, 80, with Spherical Plain Bearing GE...LO (see page 82), requiring maintenance

Greasing: up to size 12 without lubrication fitting
 from size 15 - 20 fitted with grease hole in housing
 from size 25 fitted with hydraulic grease nipples to DIN 71412

On request: Housing: Stainless steel to 1.4401 or 1.4301
 from size 10 to 80 available with maintenance free stainless steel Spherical Plain Bearing GE..EC-NIRO (see page 71)

Hydraulic Rod Ends - Weld-On Base

Series FS..N

Rod Ends with rectangular surface for Weld-on. Spherical Plain Bearings, regreasable, fixed with snap rings

For Weld-On to cylinder bottoms

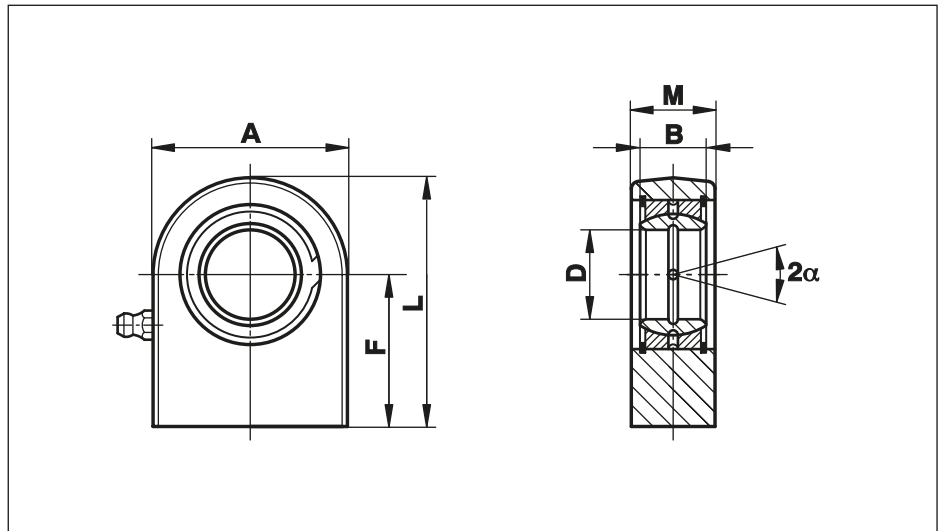

Size (D)	B	M	A	F	L	Static load C ₀ kN	Dynamic load C kN	Maximum Pivoting Angle α (°)	Weight g
15	12	16,0	45	31	53,5	53,0	17,0	8	220
16	14	17,5	48	35	59,0	59,0	21,2	10	290
17	14	17,5	48	35	59,0	65,0	21,2	10	290
20	16	19,0	50	38	63,0	67,0	30,0	9	360
25	20	23,0	55	45	72,5	69,5	48,0	7	530
30	22	28,0	65	51	83,5	118,0	62,0	6	850
35	25	30,0	83	61	102,5	196,0	80,0	6	1500
40	28	35,0	100	69	119,0	305,0	100,0	7	2420
45	32	40,0	110	77	132,0	386,0	127,0	7	3390
50	35	40,0	123	88	149,5	441,0	156,0	6	4240
60	44	50,0	140	100	170,0	570,0	245,0	6	7100
70	49	55,0	164	115	197,0	724,0	315,0	6	10700
80	55	60,0	180	141	231,0	804,0	400,0	6	15100
90	60	65,0	226	150	263,0	1340,0	490,0	5	23400
100	70	70,0	250	170	295,0	1516,0	610,0	7	33100
110	70	80,0	295	185	332,5	2340,0	655,0	6	48500
120	85	90,0	360	210	390,0	3210,0	950,0	6	79500

Materials:

Housing: St 52-3, forged

Bearing: Steel on Steel bearing GE...E, requiring maintenance (see page 78)

Greasing: fitted with hydraulic grease nipple to DIN 71412

On request: Housing: Stainless steel to 1.4401/1.4404 or 1.4301 with maintenance free stainless steel Spherical Plain Bearing GE..EC-NIRO (see page 71)

Angle Joints

Angle Joints to DIN 71802

consisting of ball stud to DIN 71803 and ball journal to DIN 71805

Form C with threaded stud and hexagon nut.

Form CS with threaded stud, hexagon nut and external clip

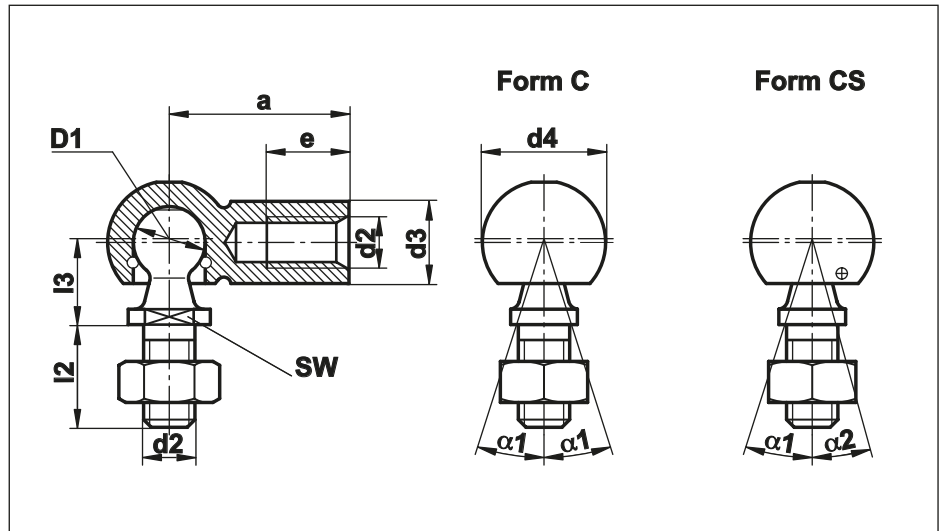

Size (D)	a ±0,3	d2	d3 ±0,5	d4 ±0,5	e min	l2 ±0,3	l3 ±0,3	SW h14	α 1 (°)	α 2 (°)	Weight g
8	22	M 5	8	12,8	10,2	10,2	9	7	18	10	15,2
10	25	M 6	10	14,8	11,5	12,5	11	8	18	15	25,2
13	30	M 8	13	19,3	14,0	16,5	13	11	18	15	53,1
16	35	M 10	16	24,0	15,5	20,0	16	13	18	15	104,0
16	35	M 12	16	24,0	15,5	20,0	16	13	18	15	104,0
19	45	M 14x1,5	22	30,0	21,5	28,0	20	16	18	15	221,0
19	45	M 14x2	22	30,0	21,5	28,0	20	16	18	15	221,0

Materials:

Ball Journal: Steel, minimum strength $R_m = 500 \text{ N/mm}^2$

Ball Stud: Steel, minimum strength $R_m = 600 \text{ N/mm}^2$

Surface: blanc, zinc plated white, on request: yellow or black chromated

Alternative: stainless steel to 1.4305, Aisi 303

Ordering Details:

e.g. Angle Joint with external clip, Form CS with ball diameter $D_1 = 10 \text{ mm}$:

Angle Joint DIN 71802 - CS 10

Left Hand Thread: Left hand thread only at the ball journal available:

Angle Joint DIN 71802 - CS 10 LH

Loose Fit: increased internal clearance available:

Angle Joint DIN 71802 - CSL 10

Fork Heads / Fork Ball Joints

Fork Heads to DIN 71752 Fork Ball Joints to DIN 71751

With ES-Bolt (clevis
spring pin) or cotter bolt

For use to transmit
linear movements

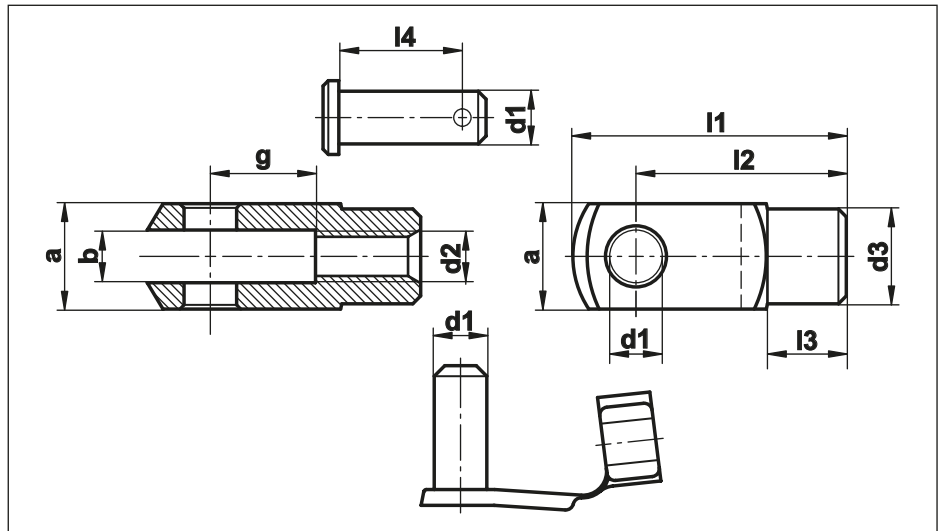

Size	g	a	b B13	d1 H9/h11	d2	d3	l1	l2	l3	l4	Weight g		
											ES-Bolt	Cotter Bolt	Fork Head DIN 71752
4x8	8	8	4	4	M 4	8	21	16	6,0	9,2	1,5	1,4	5
4x16	16						29	24			7		
5x10	10	10	5	5	M 5	9	26	20	7,5	12,0	2,7	2,4	9
5x20	20						36	30			13		
6x12	12	12	6	6	M 6	10	31	24	9,0	14,5	4,6	4,4	15
6x24	24						43	36			22		
8x16	16	16	8	8	M 8	14	42	32	12,0	18,7	10,4	9,4	37
8x32	32						58	48			54		
10x20	20	20	10	10	M 10	18	52	40	15,0	23,2	19,0	17,8	74
10x40	40						72	60			116		
12x24	24	24	12	12	M 12	20	62	48	18,0	28,2	33,5	33,6	121
12x48	48						86	72			175		
14x28	28	27	14	14	M 14	24	72	56	22,5	31,2	45,0	50,7	178
14x56	56						101	85			258		
16x32	32	32	16	16	M 16	26	83	64	24,0	36,2	70,0	74,7	282
16x64	64						115	96			410		
20x40	40	40	20	20	M 20	34	105	80	30,0	47,0	132,0	130,0	520

Materials:

Standard Series: steel 12L13, tensile strength 550 to 700 N/mm²
Surface: zinc plated and chromated, on request: blanc, oiled or phosphated and oiled

On request: stainless series, stainless steel to 1.4305, Aisi 303
ES-Bolt not in stainless steel available

Ordering Details:

Fork Head: e.g. Form G with bore size **d1** = 12mm, split length **g** = 24mm:
Fork Head DIN 71752-G12x24

Fork Ball Joint: e.g. Fork Ball Joint with Cotter Bolt, with bore size **d1** = 12mm, split length **g** = 24mm:
Fork Ball Joint DIN 71751-A12x24

e.g. Left Hand Thread: **DIN 71752-G12x24LH** and **DIN 71751-A12x24LH**

Rubber Seals

RERS

Rubber Protector Caps
made from Neoprene

Protects against dust, chemical substances and aggressive environment. Resistant to oil, grease, saltwater, chemical components and other substances.

Temperature range from -20° till +120° Celsius or -4° till +248° Fahrenheit.

Can be completely filled with grease. Mounted easily with Seeger retaining pliers

* Spacers separately on request

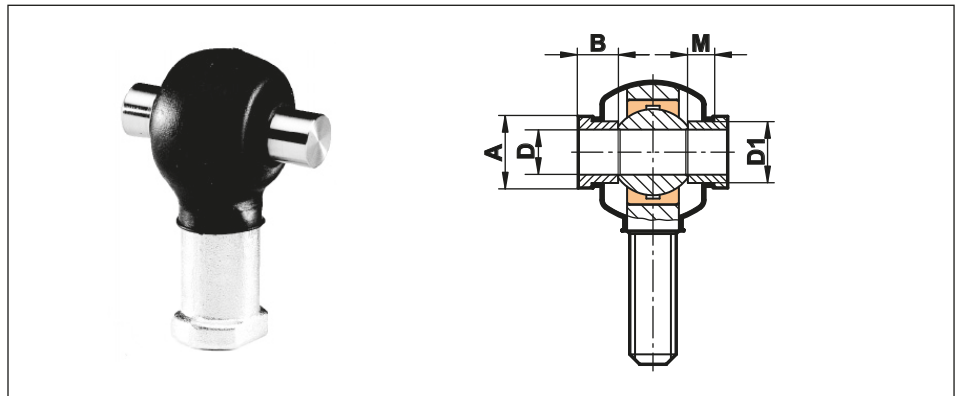

Rod End Size	Rubber Protector Cap Type	Spacers Type*	D	D1	B	M	A
6	RERS 1	DR 6	6	8,7	6	4	11
8	RERS 1	DR 8	8	10,3	6	4	12
10	RERS 2	DR 10	10	12,5	6	4	14
12	RERS 2	DR 12	12	15,0	8	6	17
14	RERS 3	DR 14	14	16,8	8	6	19
16	RERS 3	DR 16	16	19,0	8	6	21
18	RERS 3	DR 18	18	21,8	8	6	25
20	RERS 4	DR 20	20	24,3	10	8	28
22	RERS 4	DR 22	22	25,7	10	8	29
25	RERS 4	DR 25	25	29,7	10	8	33
30	RERS 5						
35	RERS 5						

RELS

Washer Seals
Rubber Seals
vulcanized to
stainless steel washer
rings

Prevents dirt entering the mating surface.
Easily mounted.
Temperature resistant up to +110° Celsius or +230° Fahrenheit

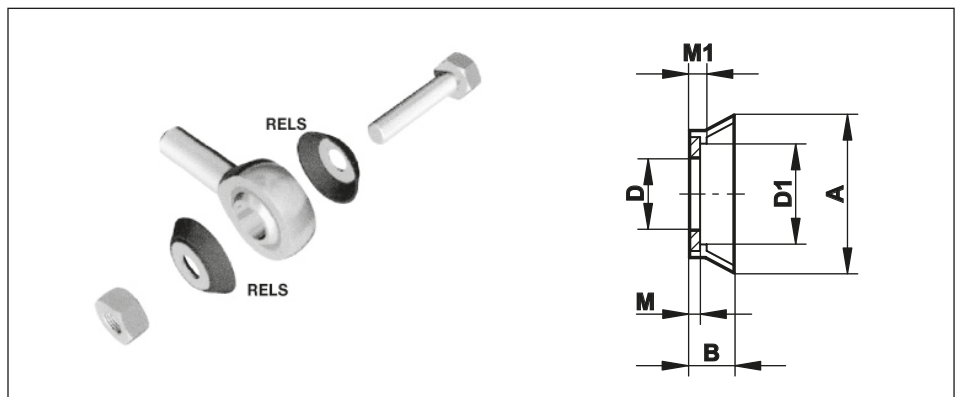

Rod End / Spherical Plain Bearing size	Washer Seal Type	D	D1	B	M	M1	A
5	RELS 5	5,25	8,3	2,4	0,50	0,8	11,2
6	RELS 6	6,25	9,5	3,1	0,69	0,9	12,7
8	RELS 8	8,25	12,4	5,1	1,20	1,4	17,8
10	RELS 10	10,25	13,5	5,6	1,20	1,4	20,3
12	RELS 12	12,25	18,5	6,4	1,20	1,7	28,6
14	RELS 14	14,25	18,5	6,4	1,20	1,7	28,6
16	RELS 16	16,25	22,4	6,8	1,20	1,7	31,7
18	RELS 18	18,25	22,6	8,3	1,20	1,7	32,7
20	RELS 20	20,25	25,2	10,2	1,20	1,7	38,1
25	RELS 25	25,25	33,8	12,7	1,50	2,3	53,3
30	RELS 30	30,25	55,9	14,0	1,50	2,3	56,7

Jam Nuts to DIN 934 / 439

Normal Form
DIN 934 / ISO 4032

Narrow Form
DIN 439 / 936

Jam Nuts with right or left hand thread. Steel zinc plated or stainless Steel A2

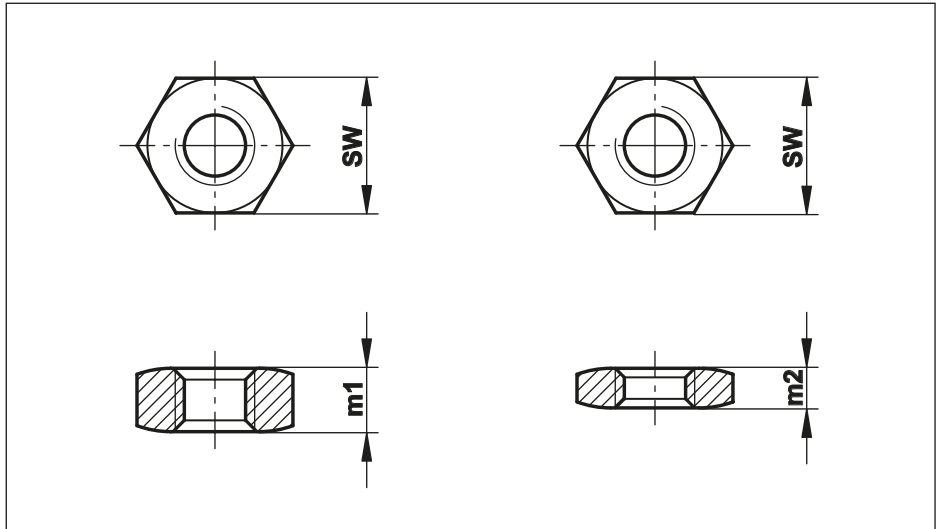

Nominal Size	Standard Thread Pitch	SW	Thread Pitch M ...												ISO 4032/DIN934		ISO 4036/DIN439	
			x0,4	x0,5	x0,7	x0,8	x1,0	x1,25	x1,5	x1,75	x2,0	x2,5	x3,0	x4,0	m1	Weight g	m2	Weight g
M 3	(M 3x0,5)	5,5		X											2,4	0,4	1,8	0,3
M 4	(M 4x0,7)	7,0			X										3,2	0,8	2,2	0,6
M 5	(M 5x0,8)	8,0				X									4,0	1,2	2,7	0,8
M 6	(M 6x1)	10,0					X								5,0	2,4	3,2	1,5
M 8	(M 8x1,25)	13,0					X	X							6,5	5,1	4,0	3,1
M 10	(M10x1,5)	17,0					X	X	X						8,0	11,1	5,0	6,9
M 12	(M 12x1,75)	19,0						X	X	X					10,0	16,3	6,0	9,8
M 14	(M 14x2)	22,0									X				11,0	24,0	7,0	15,0
M 16	(M 16x2)	24,0							X		X				13,0	32,0	8,0	19,5
M 18	(M 18x2,5)	27,0							X						15,0	47,0	9,0	28,0
M 20	(M 20x2,5)	30,0							X			X			16,0	61,0	10,0	38,0
M 22	(M22x2,5)	32,0							X						18,0	75,0	11,0	46,0
M 24	(M 24x3)	36,0									X				19,0	104,0	12,0	66,0
M 27	(M 27x3)	41,0									X				22,0	158,0	13,5	96,0
M 30	(M 30x3,5)	46,0									X				24,0	219,0	15,0	137,0
M 36	(M 36x4)	55,0									X		X		29,0	370,0	18,0	230,0
M 39	(M 39x4)	60,0											X		31,0	470,0	19,5	300,0
M 42	(M 42x4,5)	65,0									X		X		34,0	610,0	21,0	380,0
M 45	(M 45x4,5)	70,0											X		36,0	750,0	22,5	470,0
M 48	(M 48x5)	75,0									X				38,0	910,0	24,0	580,0
M 52	(M 52x5)	80,0											X		42,0	1130,0	26,0	700,0
M 56	(M 56x5,5)	85,0												X	45,0	1350,0	28,0	840,0
M 64	(M 64x6)	95,0												X	51,0	1850,0	32,0	1160,0

X) available ex stock, Standard Form only with standard thread in stock

Materials: steel galvanised, strength grade: 04 or better, or alternative A2 (which is equivalent to stainless steel 1.4301, Aisi 304 and 1.4303, Aisi 305)

Thread: Right hand or left hand threads

Remarks: Across-flats dimension SW, Weight, Width m1/m2 and Chamfer can differ from the table above and the DIN, because of different manufacturing methods
Jam Nuts DIN 439 according to **ISO 4036** (without chamfer) or **ISO 4035** (with chamfer).
Jam Nuts DIN 439 Fine Thread according to **ISO 8675** (with chamfer).

Ordering e.g. **Jam Nut M 10 Left Hand** (Normal Form with standard thread) in stainless steel A2:

Details: **Jam Nut DIN 934-M10-A2-Left Hand**
e.g. **Jam Nut M 39x3 Right Hand** (Narrow Form) in Steel, zinc plated:
Jam Nut DIN 439-M39x3-04

Höhn Precision Parts - this name represents quality production. Fifty years of experience guarantee the companies reliable capability. The continuously modernized machine park enables a flexible and economic production of turned and machined parts.

Variety for Höhn does mean that besides the turning, machining and grinding of parts, also complete components and assemblies are manufactured.

In agreement with the TÜV Southwest, Höhn received stamp authorization for continued re-stamping of material specification 3.1.B. since 1981. Höhn achieved also the

DIN EN ISO 9001:2000 certification.

5-axial
symmetric machining
(3-D measuring machine)

Höhn processes all sorts of steel e.g.: Titan, Hasteloy, 17-4Ph, non-iron and non-ferrous heavy metal. Though constant stock of stainless steel material such as 1.4104, Aisi 430F, 1.4122, 1.4301, Aisi 304, 1.4401, Aisi 316, 1.4404, Aisi 316L, 1.4034, Aisi 420, 1.4057, Aisi 431, 1.4305, Aisi 303, 1.4571, Aisi 316Ti, 1.4541, Aisi 321 a prompt delivery response is guaranteed.

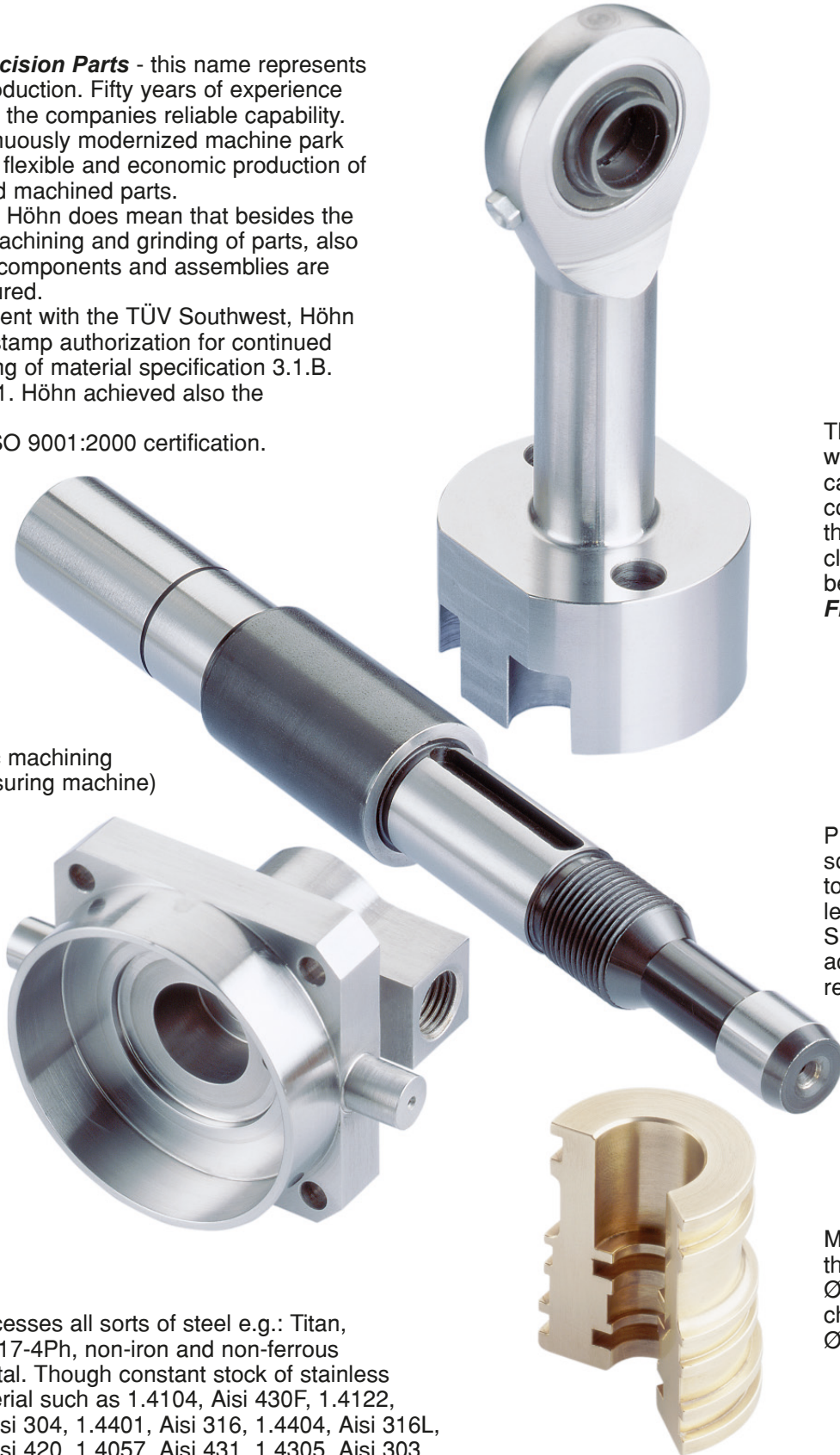

This connecting rod with bearing for carriages shows a constructive solution through the close cooperation between **Höhn** and **FLURO®**.

Production of all sorts of shafts, \varnothing 20 to \varnothing 120 x 1000 mm length. Surface finish according to customer requirements.

Machining of the rod from \varnothing 10 to \varnothing 80 mm, chucking parts from \varnothing 10 to \varnothing 400 mm.

Company: _____ Contact: _____ Phone: _____

Center Distance = _____ mm

Thickness $t =$ _____ mm (observe Spherical width!)
 Material: _____ with 2x Sphericals: _____

Please indicate: Form A Form B

Center Distance = _____ mm Adjustable Range = +/- _____ mm

Ridge to identify left hand thread
 Left hand thread
 Hexagon SW = _____ alternative: Pipe \varnothing _____ with cross bore
 Length = _____ mm Material: _____
 Lock Nut DIN 439 (flat) Material: _____
 Rod End _____

Center Distance = _____ mm Adjustable Range = +/- _____ mm

Left hand thread
 Threaded Rod Length = _____ mm Material: _____
 Lock Nut DIN 439 (flat) Material: _____
 Rod End _____

with incorporated Spherical Type: _____
 Head Width $M =$ _____ mm, Ball Width $B =$ _____ mm
 Thread Length $GL =$ _____ mm, Thread $G =$ _____

Material Ball: _____
 Material Outer Ring: _____
 Maintenance free: Yes No

Custom-Made Products



Rosenfeld is situated between the city of Stuttgart and the lake Bodensee, in southern Germany. You can get to us easily from the international airport of Stuttgart by car. Drive Highway A81 south (towards Singen), exit at Oberndorf and follow the road to Rosenfeld. Our company's plant is situated in the midst of an industrial area on the right hand side behind the town's entrance. We invite you to pay a visit at our manufacturing plant to see our capability.

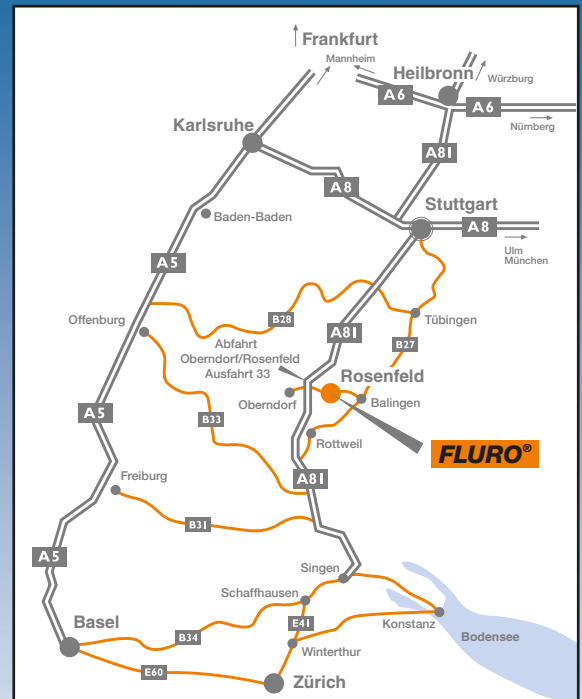

This is how you can get to us.



FLURO®-Gelenklager GmbH

Siemensstrasse 13
72348 Rosenfeld / Germany
Phone +49 (0) 74 28 93 85-0
Fax +49 (0) 74 28 93 85-25
www.fluro.de
info@fluro.de